



Seismic Retrofit Guide



IMPROVE YOUR HOME'S EARTHQUAKE RESISTANCE

This *Seismic Retrofit Guide* is designed to promote public safety and welfare by reducing the risk of earthquake-induced damage to existing homes. In the aftermath of a major seismic event, those who reside in homes rendered uninhabitable by damage incurred in the initial or subsequent events will find themselves without shelter. This can place a severe burden on public facilities to house displaced residents until repairs or relocation can take place.

The guidelines in the pages that follow provide Simpson Strong-Tie product solutions that meet the prescriptive minimum standards of the 2012 International Existing Building Code (IEBC) and are intended to improve the ability of structures to withstand seismic forces. These guidelines will not prevent earthquake damage, and only apply to homes with crawl spaces and cripple walls. For conditions other than those shown, or for a complete evaluation of a building or home, a licensed structural engineer or other qualified design professional should be consulted.

Before starting any retrofit or repair, check with your local building department for requirements in your area, which may include stricter standards than those shown in this guide. The information in the *Seismic Retrofit Guide* is intended to demonstrate how Simpson Strong-Tie® products should be installed. Designers should refer to the current Simpson Strong-Tie *Wood Construction Connectors* catalog or www.strongtie.com for additional information.



Why Should I Retrofit My Home?

During an earthquake, the strength of a house is put to the test. Ground forces try to tear it apart and in many cases, cause severe damage. If you live in an area prone to earthquakes, it's important that the structural frame of your home is strong enough to absorb an earthquake's energy (see *Continuous Load Path*, page 4). Fortunately, advances in structural engineering, lessons learned from past earthquakes and research performed by the scientific community have paved the way for the development of new construction techniques that better equip houses to withstand an earthquake. Local and regional building codes now require all new houses to meet these higher construction and safety standards.

This flier offers solutions that meet the minimum prescriptive standards of IEBC Chapter A3.

For homes with raised-floor or cripple wall foundation, the International Existing Building Code (IEBC) Chapter A3 provides detailed retrofit provisions that are intended to improve the seismic performance of the structure and to reduce the risk of earthquake damage.

This flier offers retrofit solutions using products from Simpson Strong-Tie that meet the minimum prescriptive standards of the IEBC Chapter A3.

Simpson Strong-Tie, the industry leader in structural product solutions, opened a research laboratory in 2003 to better understand the effects of earthquakes, high winds, and other natural disasters on a building's performance. The lab's state-of-the-art testing equipment can simulate the magnitude of seismic events like the 1989 Loma Prieta quake in California, which measured 6.9 on the Richter scale. This ongoing

testing and research is being conducted with the sole purpose of improving building design and safety through enhanced product development.

Simpson Strong-Tie is committed to helping homeowners understand

how to strengthen and protect their homes against the effects of earthquakes and other natural disasters. This guide is designed to help you understand some of the basic principles of a house retrofit and provide step-by-step instruction, per IEBC Chapter A3, on methods to strengthen and protect your own home.

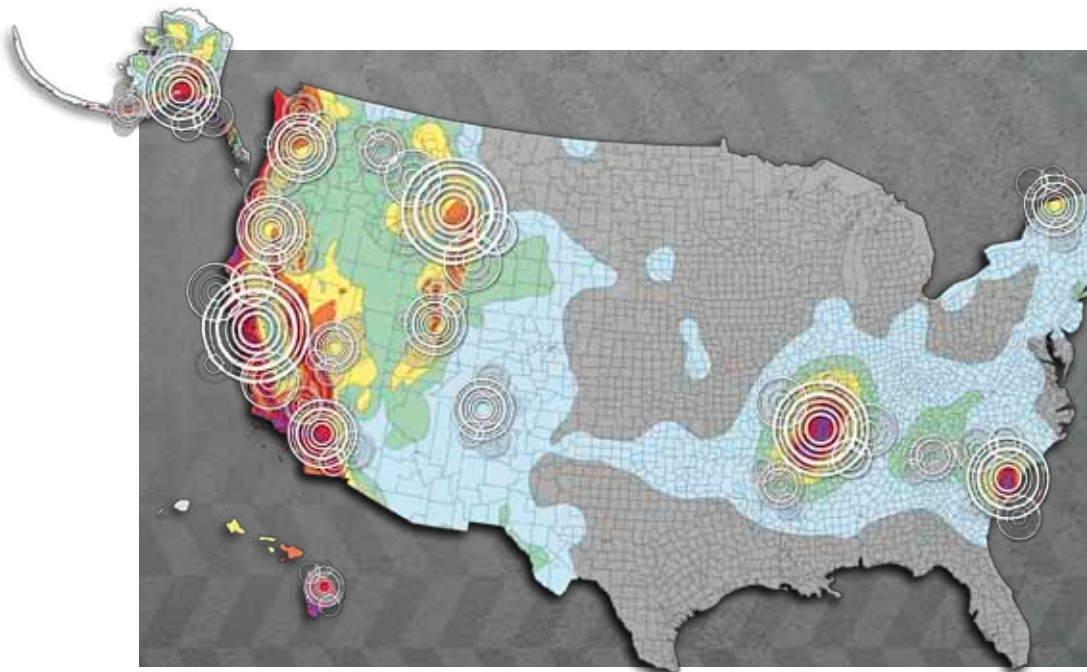

Reasons to Retrofit:

- You reside in an active seismic zone (shown at left)
- You and your home will have a better chance of surviving an earthquake
- To improve your home's ability to act as shelter after a seismic event
- To reduce the cost of repair following an earthquake
- Retrofitting your home can potentially reduce earthquake insurance premiums and deductibles

Before you begin a retrofit project, it's important that you are familiar with the basic principles of residential construction and how earthquakes impact your home.

Earthquake Basics: Lateral and Uplift Forces

During an earthquake, a house experiences two types of forces: lateral forces and uplift forces. Lateral (or *shear*) forces are horizontal forces that result in back and forth (*side to side*) movement, also known as racking. Lateral forces can shake the house and weaken its frame and cause it to slide off the foundation. Uplift forces are vertical forces that result in up and down movement. Uplift forces can cause the house to overturn and lift off the foundation.

Using a continuous load path throughout the home strengthens the entire structure and helps it to resist lateral and uplift forces.

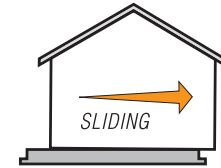

How Earthquake Forces Affect A Home

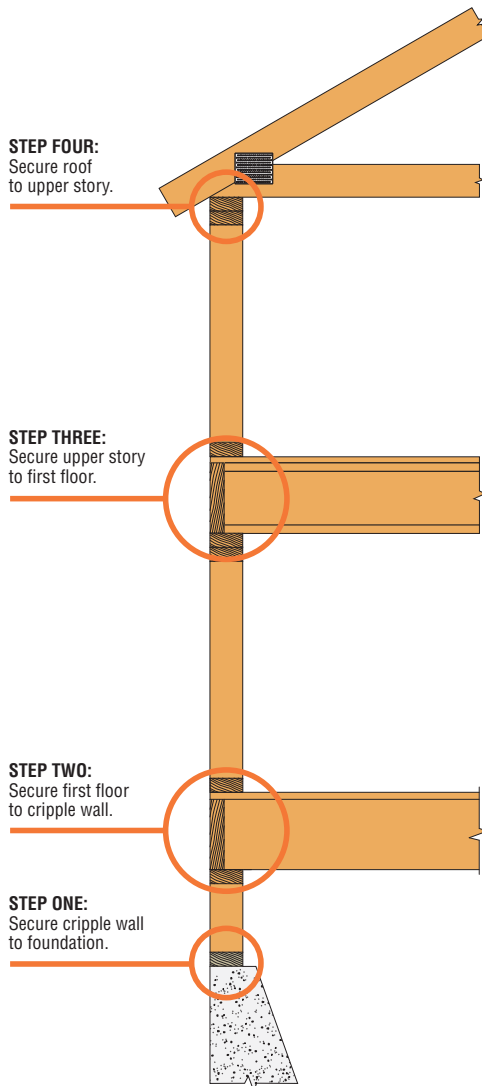

Continuous Load Path*

Earthquake Basics: Continuous Load Path

Building codes now require houses to meet higher structural design standards, including the use of a “continuous load path.” This method of construction involves creating a series of solid connections throughout the structure. These connections are created by using a system of wood framing, metal connectors, fasteners (*like nails and screws*) and shearwalls.

These connections are critical during an earthquake. A continuous load path redistributes external forces from an earthquake by transferring these forces from the frame of the house to the foundation. A home is more likely to withstand an earthquake and stay intact when each part of the house is connected together.

In general, houses built within the last 25 years should have been constructed with a continuous load path. To confirm this was done in your home, you can hire a professional contractor or qualified design professional to perform a structural evaluation of your house. When hiring a design professional, you want to make sure they are licensed to practice in your state and have a good reputation. You should ask for references and check with the Better Business Bureau.

**Note: This Seismic Retrofit Guide does not attempt to create a continuous load path, but provides practical solutions to reinforce your home.*

There are certain types of houses that are more likely to need a retrofit than others. A quick analysis of your home can help determine if it fits the criteria.

1. Am I living in an area prone to earthquakes?

There are geographic areas that are considered high seismic regions. These seismic areas are based on the likelihood of an earthquake occurring and its severity. The easiest way to find out if you are living in a high seismic area is to call your local building department and ask if you are in Seismic Design Category D, E or F. These designations are assigned to regions with high seismic potential.

2. Was my home built within the last 25 years?

As a general rule of thumb, houses built within the last 25 years were designed to conform to stricter building codes and will be better equipped to resist the force of an earthquake. Houses built prior to that timeframe are typically more vulnerable to earthquake damage.

3. Is my home built on a raised foundation?

If your home is not built directly on a concrete slab, chances are it's built on a raised foundation. This means the house was built on a system of posts, beams and "cripple walls" (*cripple walls are short wood-framed walls running underneath and around the perimeter of the house*). These houses typically have crawl spaces underneath them. They are susceptible to damage because the supporting structure under the house may not have been anchored to resist seismic forces and thus is considered a weak area. Past earthquakes have shown these areas are highly susceptible to structural failures as shown in the illustration below.

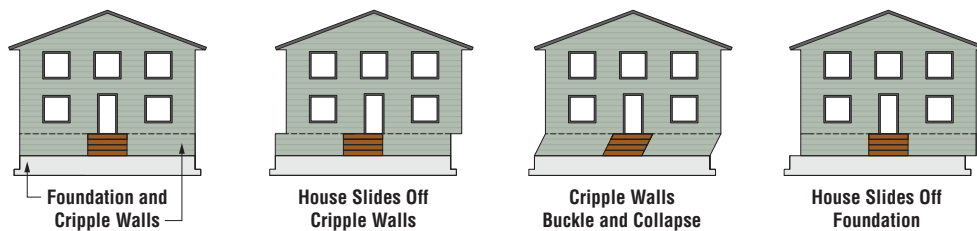

4. Is my home built on a hillside?

Houses built on a hillside typically have raised foundations and crawl spaces as those described above and can experience similar failures. However, these failures tend to be more severe because the posts and cripple walls supporting the home are built at different heights due to the uneven terrain.

5. Is there living space above my garage?

Garages are vulnerable areas in a house due to the large garage door opening. Because of this large opening, the narrow walls on either side of the garage door must be designed to resist earthquake forces. This is extremely important if there is a living space above the garage because these rooms add weight that the garage must support. Current building codes require that these narrow walls be specially designed to resist earthquake forces. Older houses, however, typically were not designed to address this issue and are more vulnerable to damage during an earthquake as shown in the illustration below.

If you live in an older house with a living space above the garage or on a hillside, you'll need to consult with a licensed structural engineer for design solutions.

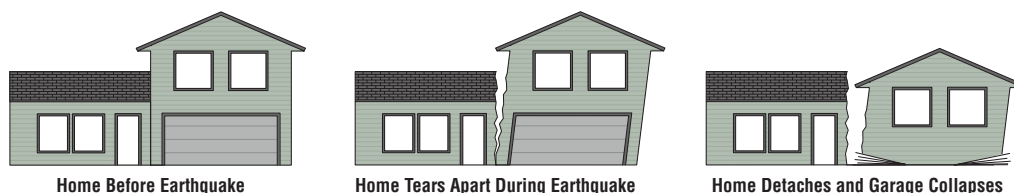

Conduct Your Own Survey

Once you have identified that there is a potential need to retrofit your home, you should then conduct your own inspection and evaluate its structural integrity. Hiring a professional to help with this evaluation is recommended, but not required. Since retrofits are not mandatory, building departments typically do not require the use of an engineer, architect or a licensed contractor as long as the house falls within certain prescriptive parameters (*Note: you should contact your building department to make sure there are no special requirements*). The building code does provide construction details for retrofitting the supporting perimeter walls of the crawl space, and with the right tools, a motivated homeowner can do this themselves. However, before getting out your tools, you must access your crawl space and evaluate the following items:

1. Is the top of the crawl space perimeter wall properly attached to the floor system?
2. Are the crawl space perimeter walls too tall?
3. Are the interior columns attached properly to the beams they are supporting?
4. Are the bottom plates of the crawl space perimeter walls properly attached to the foundation?
5. Are the crawl space perimeter walls reinforced with plywood or oriented strand board (OSB) panels?

Note: It's important when you evaluate your crawl space to check existing lumber and new wood framing materials for decay and rot. When wood is exposed to moisture, it can rot and possibly weaken the wood structure. If you suspect wood decay, you'll need to contact a licensed structural engineer and/or contractor for design solutions.

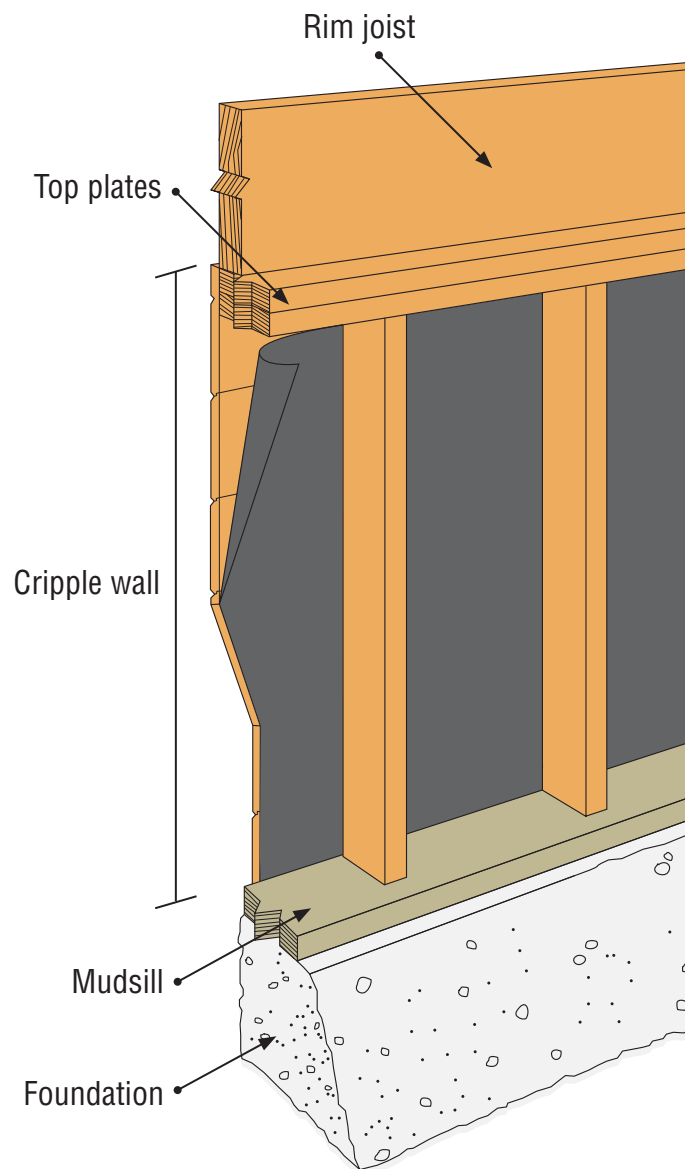

1. Is the top of the crawl space perimeter wall properly attached to the floor system?

On top of the crawl space wall rests the floor system. Around the outside of the floor system and the perimeter wall system is what is known as the rim joist. The rim joist should be attached to the top of the wall with metal connectors. The connectors should be located approximately 16" on center.

2. Are the crawl space perimeter walls too tall?

In order to use this retrofit guide, the perimeter walls of your home must not be too tall. To determine this, you need to measure the distance from the top of the concrete foundation to the top of the perimeter wall (*or the bottom of the floor system*). In certain cases, an engineer must design your retrofit solution, these include:

- If your home is one or two stories and the perimeter wall height is greater than 4' at any point
- If your home is three stories and the perimeter wall height at any point is greater than 14'
- If your home is more than three stories.

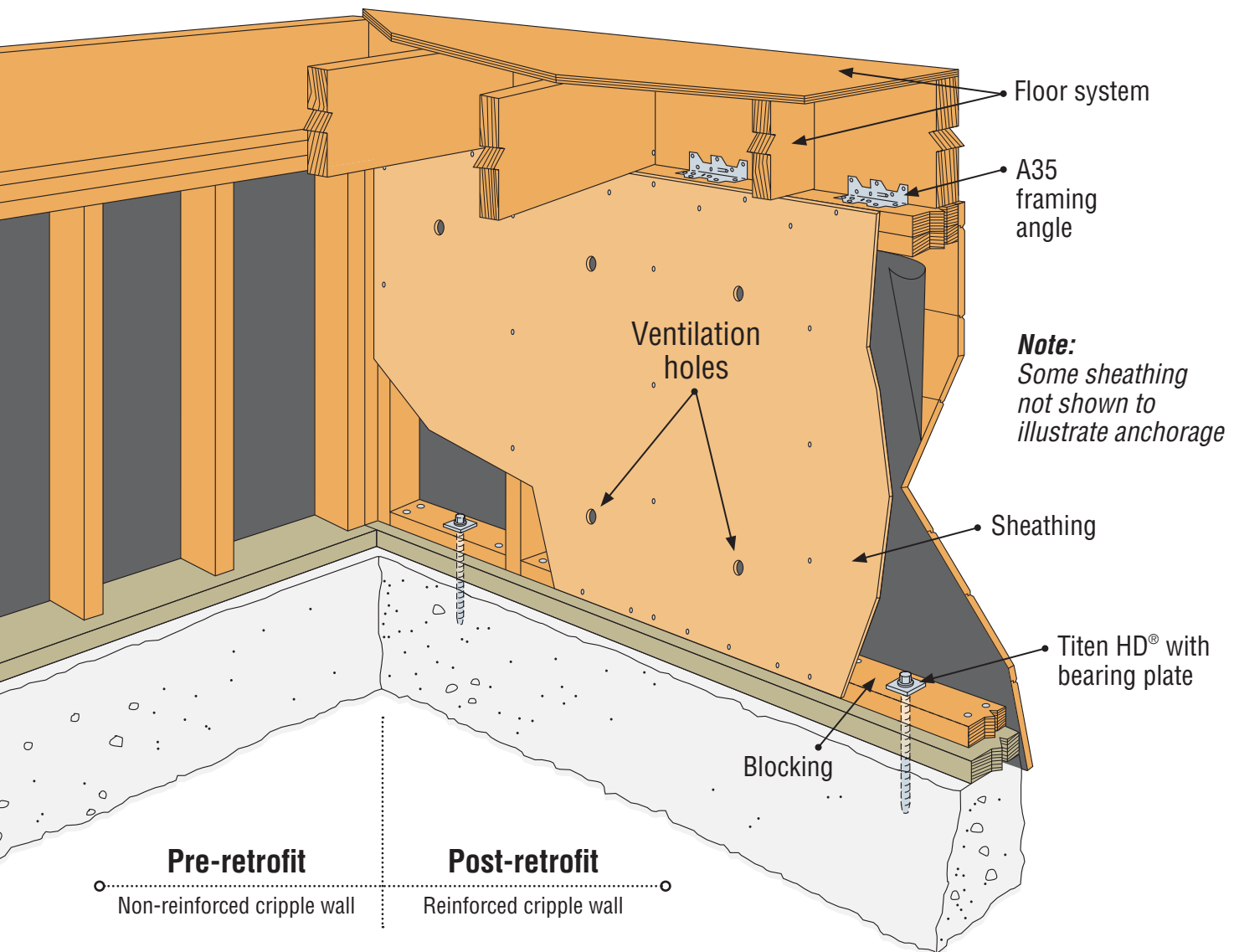

3. Are the interior columns attached properly to the beams they are supporting?

Often there are interior columns supporting the floor system (*not shown above, see page 16*). The tops of these columns should be attached to the floor beams with a metal connector.

4. Are the bottom plates of the crawl space perimeter walls properly attached to the foundation?

Building codes require that anchor bolts should be placed at certain locations to prevent the home from sliding off of the foundation. According to the code, anchor bolts must be located 9" to 12" from the end of each mudsill plate and no more than 6' on center (o.c.) for one and two-story homes. The bolts may require a bearing plate between the top of the sill plate and the nut. Check with your local building department for requirements in your area. The bolts should be undamaged and rust-free.

5. Are the crawl space perimeter walls reinforced with plywood or OSB panels?

Perimeter walls must be reinforced to prevent the house from falling over during an earthquake. This is typically done by installing plywood or OSB sheathing panels on the outside of the walls. Older homes often did not use this type of sheathing. Instead siding boards were used, but not attached to prevent failures. The building codes recommend the installation of 1/2" plywood or OSB panels to the inside face of the walls in strategic locations to strengthen the perimeter walls.

I Know I Need to Retrofit My Home, How Do I Get Started?



Now that you have identified the areas of your home that may need reinforcing, this next section addresses how you can do the work yourself.

Before you begin your retrofit project, you'll need to determine whether or not your home has cripple walls. Cripple walls are the short wood-framed walls running underneath and around the perimeter of your house. These walls are constructed on top of the foundation and are generally 12" to 30" high. Where cripple wall height exceeds 48", a qualified design professional is required to evaluate the condition.

Start by answering the following questions:

- Does your house have a cripple wall between the foundation and floor framing?
- If your house has a cripple wall, how tall is it?
- If your house has a cripple wall, is the mudsill wider than the studs?

Based on your answers, you can then follow one of the retrofit scenarios listed below. Please see the page numbers referenced under each step for specific how-to instructions.

No Cripple Wall

Step 1	Step 2	Step 3
Install UFP foundation plates <i>(see page 11)</i>	Install A35 framing angles <i>(see page 15)</i>	Install AC* post caps <i>(see page 16)</i>

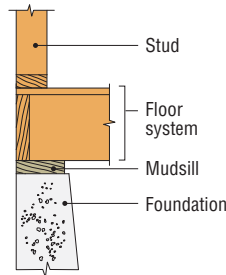

Cripple Wall Less Than 3 Ft. Tall

Cripple Wall Height	Step 1	Step 2	Step 3	Step 4	Step 5
Mudsill and studs same width	Install sheathing <i>(see page 13)</i>	Install UFP foundation plates <i>(see page 11)</i>	Install A35 framing angles <i>(see page 15)</i>	Install AC* post caps <i>(see page 16)</i>	—
Mudsill wider than stud	Install blocking <i>(see page 12)</i>	Install sheathing <i>(see page 13)</i>	Install UFP foundation plates <i>(see page 11)</i>	Install A35 framing angles <i>(see page 15)</i>	Install AC* post caps <i>(see page 16)</i>

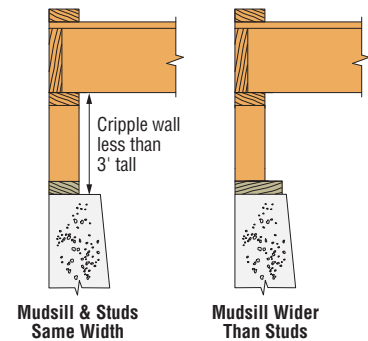

Cripple Wall 3 Ft. To 4 Ft. Tall

Cripple Wall Height	Step 1	Step 2	Step 3	Step 4	Step 5
Mudsill and studs same width	Install Titen HDs and BPs <i>(see page 10)</i>	Install sheathing <i>(see page 13)</i>	Install A35 framing angles <i>(see page 15)</i>	Install AC* post caps <i>(see page 16)</i>	—
Mudsill wider than stud	Install blocking <i>(see page 12)</i>	Install Titen HDs and BPs <i>(see page 10)</i>	Install sheathing <i>(see page 13)</i>	Install A35 framing angles <i>(see page 15)</i>	Install AC* post caps <i>(see page 16)</i>

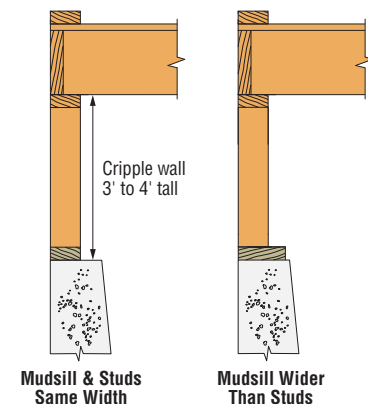

Note: If your cripple wall is taller than 4 ft., please contact a licensed engineer or architect.
* The installation of AC post caps is not required by the IEBC, Chapter A3.

Once you've determined the steps to take, next you'll need to sketch out a plan.

Start by making an outline of the perimeter walls of your house, showing where the studs are and listing all dimensions. Many of the directions in the following sections will reference the spacing at which hardware must be installed or the percentage of a wall that must be covered with plywood/OSB sheathing panels. Once you know the dimensions of the walls you can determine how many pieces of hardware or how much plywood/OSB you will need.

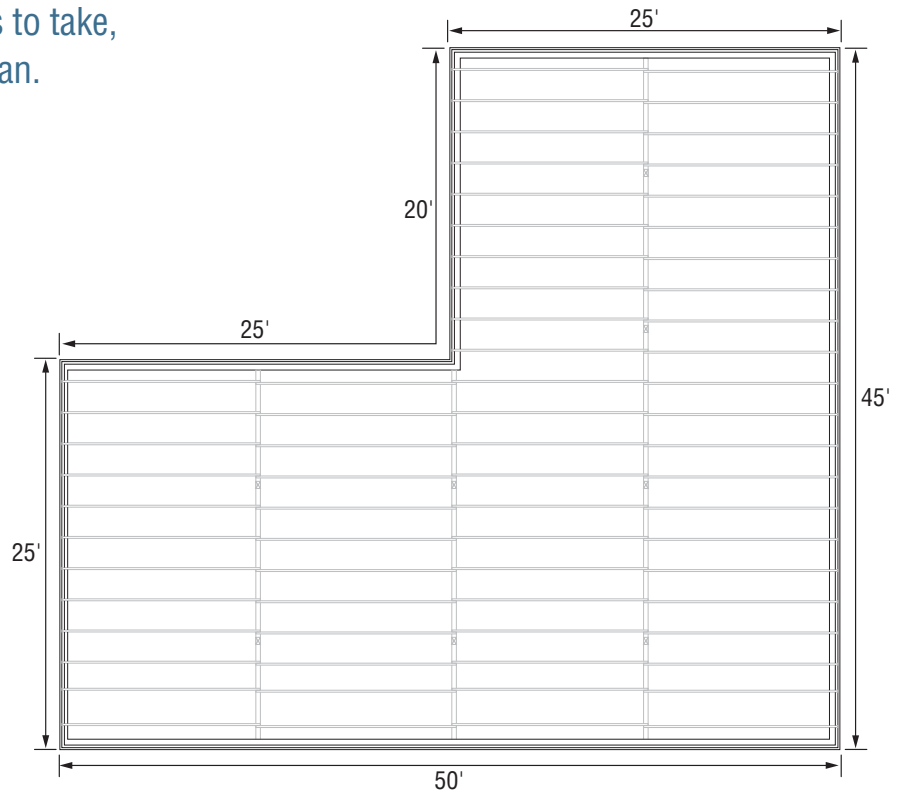

Tools Needed for Retrofitting

TOOL	PURPOSE
Measuring tape	Measuring walls, spacing, lumber
Circular saw	Cutting plywood and 2x lumber
Rotohammer drill	Drilling into concrete
Carbide-tipped drill bits ¹	For use with rotohammer <i>(bit must share compatible shank type with rotohammer)</i>
Socket wrench or impact wrench ^{1,2}	Installing Titen HD [®] screw anchors, Strong-Bolt [®] 2 wedge anchors, or threaded-rod anchor with SET-XP [®] anchoring adhesive ²
Drill with driver attachment	Driving Strong-Drive [®] SDS ($\frac{3}{8}$ " driver) or SD ($\frac{1}{4}$ " driver) screws
Hammer	Installing A35 angles in areas with clearance
Hammer or nail gun	Nailing off sheathing and installing blocking
Palm nailer <i>(optional)</i>	Installing nails in sheathing or A35 angles and blocking in areas with little vertical clearance
Air compressor	Required for nail gun or palm nailer, also handy for cleaning dust out of holes for anchors
Chalk line	Marking nail lines on sheathing
3" Hole saw drill bit	Drilling ventilation holes in sheathing

1. See selected anchor installation instructions for proper drill bit, socket or wrench size.
2. Do not install Strong-Bolt[®] 2 or threaded-rod anchors with SET-XP[®] using an impact driver.

Note: Tools such as rotohammers and air compressors are commonly available at tool rental centers. For an explanation of technical terms and symbols, please reference the glossary on pages 17.



Palm Nailer



Rotohammer Drill

Installing the Titen HD® to Anchor the Mudsill

The Titen HD is a screw anchor that is used to anchor the mudsill to the foundation. It's easy to install with just a few tools.

Installation Details

- Anchor diameter: $\frac{5}{8}$ "
- Drilled hole depth: See table for embedment depth
- Anchor length: This will be determined by the thickness of framing and embedment depth. See table.
- Anchor spacing: 6' on center (o.c.) for one and two-story homes
- Washer: The Code requires a minimum 2"x2"x $\frac{3}{16}$ " thick steel plate washer (sold separately; Simpson Strong-Tie® BP $\frac{5}{8}$ satisfies the requirement). Some jurisdictions may require larger plate washers, such as the Simpson Strong-Tie BP $\frac{1}{2}$ -3 and BP $\frac{3}{8}$ -3. Contact your local building department for requirements in your area.

Note: Existing concrete may be too hard to install Titen HD® screw anchors. Please refer to www.strongtie.com/retrofitdetail for additional anchorage and installation options.

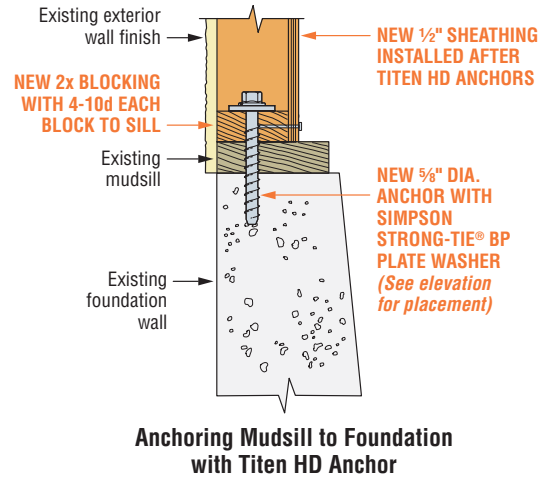
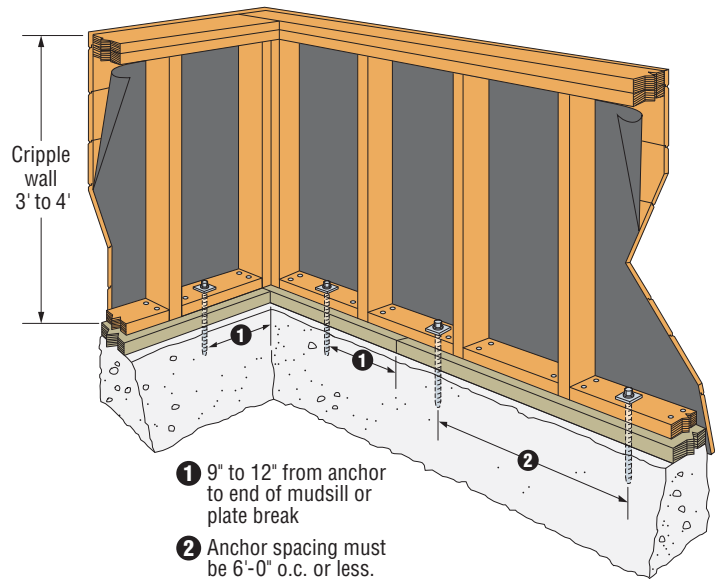

Table 1 – Determining Titen HD Length

Mudsill Thickness ¹ (in.)	Hole Depth In Foundation ² (in.)	Titen HD Model No. (Size)
1½	5	THD62600H ($\frac{5}{8}$ " x 6")
2	4½	THD62600H ($\frac{5}{8}$ " x 6")
2½	4½	THD62612H ($\frac{5}{8}$ " x 6½")
3	5½	THD62800H ($\frac{5}{8}$ " x 8")
3½	5	THD62800H ($\frac{5}{8}$ " x 8")

1. Mudsill may be single thickness or double if blocking is required for sheathing purposes.
2. Minimum required embedment for the Titen HD anchor in this application is 4". Hole depths above have been adjusted for available anchor sizes.



Instructions

1. Starting at each corner of the foundation, mark where each anchor will be installed. Make the first mark 12" from the corner (end of the mudsill). From the center of that anchor, measure and mark for a new anchor every 6'. A new anchor must also be placed a minimum of 9" and a maximum of 12" from every mudsill plate break. Reduce the 6' spacing between anchors if necessary to satisfy this requirement.
2. Using a rotohammer drill (with a $\frac{5}{8}$ " diameter bit) drill down through the center of the mudsill (or mudsill and blocking) into the top of the concrete foundation to the appropriate embedment depth shown in Table 1. (Note: Embedment is the depth of the hole from the top of the concrete, not the top of the mudsill.)
3. Clean the concrete dust from the hole using oil-free compressed air.
4. Insert the Titen HD anchor into the hole, with the square washer in place, and drive the anchor into the hole using a socket wrench or impact driver with a $\frac{15}{16}$ " socket. Drive the anchor until the head of the Titen HD anchor and the plate washer are snug against the mudsill.
5. Repeat steps 2-4 for each new anchor location identified in Step 1.

For materials and tools required, refer to worksheet on page 19.

Installing the Universal Foundation Plate (UFP)

The UFP is a retrofit foundation plate that allows the cripple wall to be anchored to the foundation from the side. This allows the product to be used in applications where minimal vertical clearance exists.

Installation Details

- Foundation plate: model UFP10
- Fasteners to mudsill: (5) Simpson Strong-Tie® SDS ¼"x3" screws (included with the UFP10)
- Anchors to foundation: (2) ½"x5" Titen HD® screw anchors (sold separately)
- Hole depth in foundation: 4¼"
- Foundation plate spacing: 6' on center (o.c.) for one- and two-story homes.

Note: Existing concrete may be too hard to install Titen HD® screw anchors. Please refer to www.strongtie.com/retrofitdetail for additional anchorage and installation options.

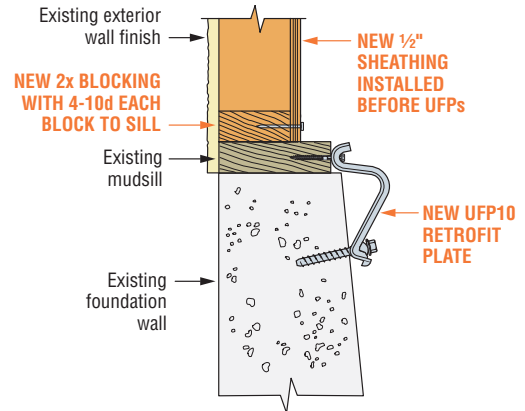

Anchoring Mudsill to Foundation with UFP

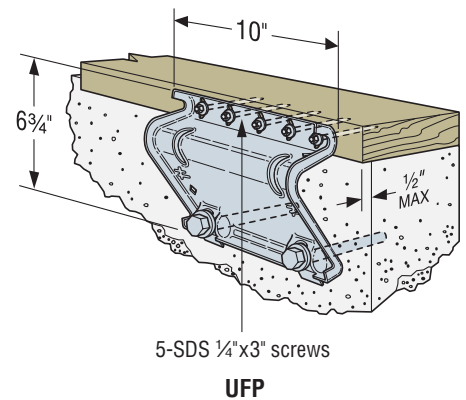
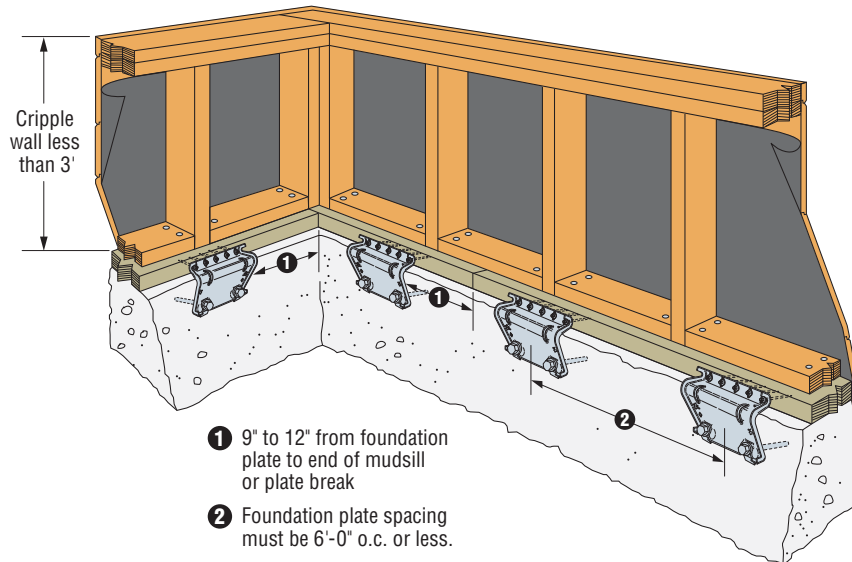

Instructions

1. Starting at each corner of the foundation, mark where each plate will be installed. Make the first mark 12" from the corner (end of the mudsill). From that point, measure and mark for a UFP every 6', with no plate being less than 12" from the break between two pieces of mudsill. If you need to adjust this spacing to account for a break in the mudsill or corner, reduce the spacing between plates.
2. Place the UFP against the bottom of the cripple wall and foundation so that it aligns correctly (as shown in the diagram above). Using a drill with a ⅜" driver attachment, drive the SDS screws into the side of the mudsill (or through the sheathing into the mudsill).
3. Using a rotohammer drill with a ½" diameter bit, use the UFP as a template and drill holes in the foundation 4½" deep. (Note: Embedment is the depth of the hole from the face of the concrete, not the face of the UFP.)
4. Clean the concrete dust from the hole using oil-free compressed air.
5. Insert the Titen HD® anchor through the UFP and drive the anchor into the hole using a socket wrench or impact driver with a ¾" socket. Drive the anchor until the head of the Titen HD anchor is snug against the UFP.
6. Repeat steps 2-5 for each UFP10 location identified in Step 1.

For materials and tools required, refer to worksheet on page 19.

In applications where the mudsill is wider than the cripple wall studs, blocking will need to be installed on top of the mudsill to provide a nailing surface for the sheathing. In order for sheathing to strengthen the cripple walls, it needs to be properly nailed on all four sides.

Installation Details

- Material: 2x blocking material equal in width to existing studs
- Nailing: (4) 10d nails per block or (4) Strong-Drive® SD #9x2½" screws
- See page 14 for instructions on determining how much blocking/sheathing your house will need and where it will be located.

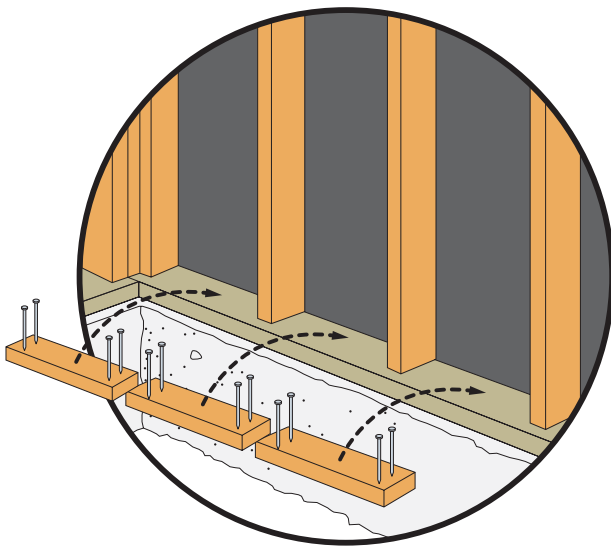

Cripple Wall Prior to “Blocking” Retrofit

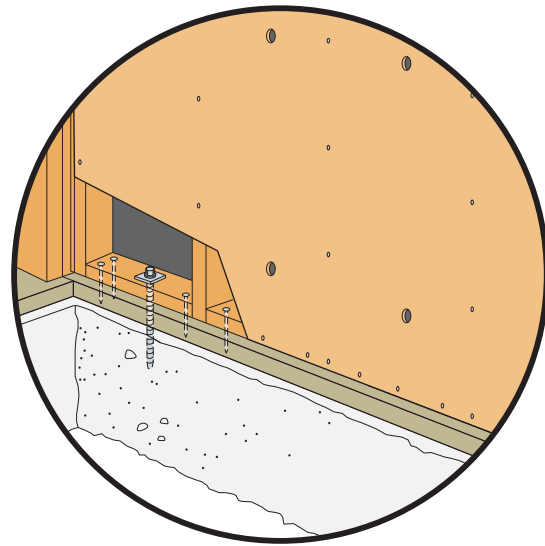

Cripple Wall with Blocking

Note: Some sheathing not shown to illustrate anchorage.

Instructions

1. Measure the space between cripple wall studs and count the number of “stud bays” (*the area between two studs*) that will be covered with sheathing (*see page 14 for instructions*).
2. Cut the appropriate number of blocks. (*Cut blocking appropriately for a tight fit.*)
3. Place the block in the stud bay on top of the mudsill, so that the interior edges of the block lines up with the inside edge of the cripple wall stud.
4. Nail the block to the mudsill with four 10d nails per block or attach with (4) Strong-Drive® SD #9x2½" screws.
5. Repeat for each stud bay until all bays to receive sheathing have blocking.

For materials and tools required, refer to worksheet on page 19.

Note: Although not necessary, if you decide to use preservative-treated wood to provide blocking, you’ll need to select connectors and fasteners with the proper protective coating. Preservative-treated wood is more corrosive than non-treated lumber. The application and type of preservative-treated wood you use will help determine the connector and fastener coating. For more information, visit www.strongtie.com/info.

Nailing sheathing onto the inside of cripple walls is required to strengthen the cripple walls under your house. Correct nailing during installation is crucial to the walls' performance.

Installation Details

- Material: ½" thick plywood or OSB
- Nailing: 8d common nails
- Every 4" on center (o.c.) into the studs at the edges of the panel
- Every 12" o.c. into the studs
- See page 14 for instructions on determining how much blocking/sheathing your house will need and where it will be located.

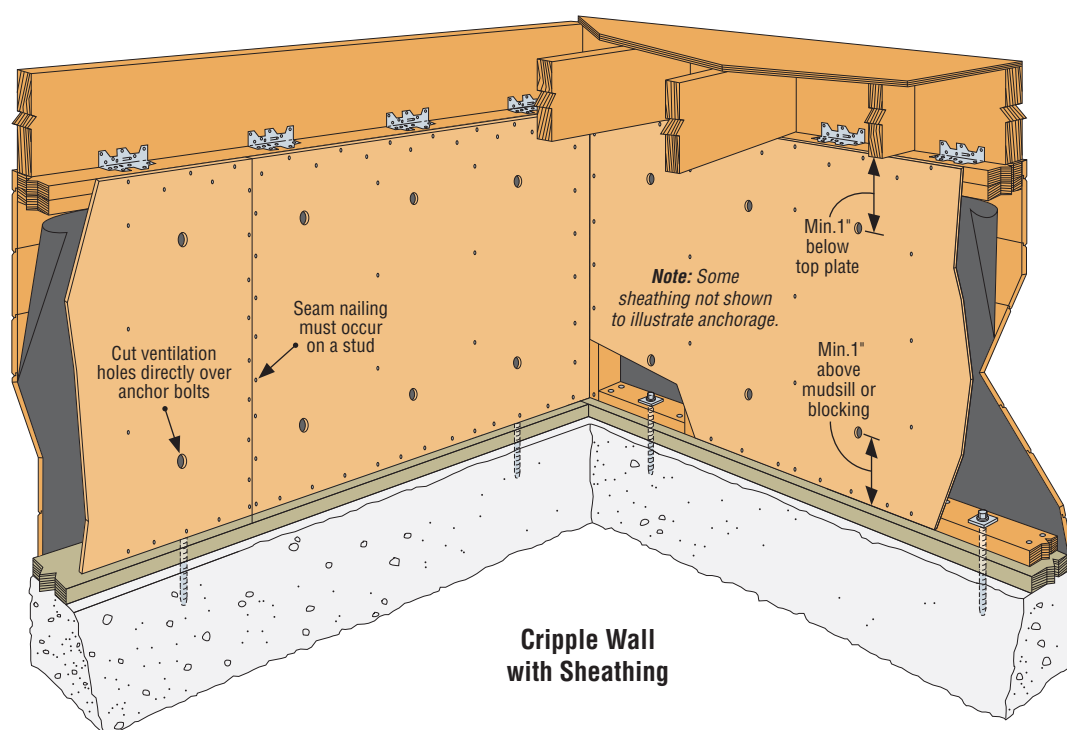

Instructions

1. Consulting your sheathing plan, measure the height and length of each sheathing run to verify dimensions. Measure from the outside edges of the two end studs in the run to determine overall length. Measure from the top of the foundation to the top of the cripple wall top plate to determine sheathing panel height. (*Note: Seams between panels must occur over a stud.*)
2. Cut plywood/OSB to size. A chalk line is helpful for making straight lines on the sheathing to ensure cuts are straight.
3. Once the pieces are cut, put them in place to verify fit. On the outside face of the sheathing, mark where the center of each stud will be underneath. Using a chalk line, mark a line to show you where to nail in order to hit the center of the stud. For situations where two pieces of sheathing are joining over a stud, measure in ¼" from the edge of each piece of sheathing and mark a line down each panel. This will show you where to nail each panel in order to hit the stud under the seam.
4. Nail the sheathing in place driving an 8d common nail every 4" o.c. around the edges, and every 12" o.c. in the center of the panel. When nailing into a double top plate or nailing seams between panels, follow a staggered nailing pattern (*as shown in the diagram*).
5. Drill (2) 2" to 3" diameter holes in the sheathing for each stud bay (*the space between two studs*) a minimum of 1" above mudsill or blocking, and 1" below the top plate for ventilation (*see diagram above for hole placement*). If the cripple wall is less than 18" tall, only one hole is required.

For materials and tools required, refer to worksheet on page 19.

How Much Blocking and/or Sheathing Do I Need?

Before you begin cutting lumber for blocking and/or sheathing, you will need to determine how much sheathing your house will require and where to install it.

The guidelines are as follows:

- One-story house: 50% of the length of each cripple wall must be sheathed.
- Two-story house: 75% of the length of each cripple wall must be sheathed
- The sheathing on any one wall can be installed in multiple runs in order to accommodate pipes, ductwork, etc. However, the length of any single run of sheathing must be equal to twice the height of the cripple wall onto which it will be installed. Example: The cripple wall is 3' tall, so no run of sheathing can be less than 6' long.
- There must be sheathing at each corner running in each direction.
Once again: Multiplying the cripple wall height by 2 equals minimum length of sheathing run.
Example: If your cripple wall is 3' tall, you'll need 6' of continuous sheathing at each corner running in each direction.
- No runs of sheathing can be more than 25' apart from center to center.

Using these guidelines, look at the sketch of the outline of your foundation/cripple walls and determine where you need to put sheathing to satisfy the guidelines above. Each sheathing run must begin on a stud and end on one so that the ends can be properly nailed off. Any seams between pieces of sheathing must also occur over a stud for nailing purposes. It is a good idea to go underneath your house to verify that you will be able to install sheathing per your plan.

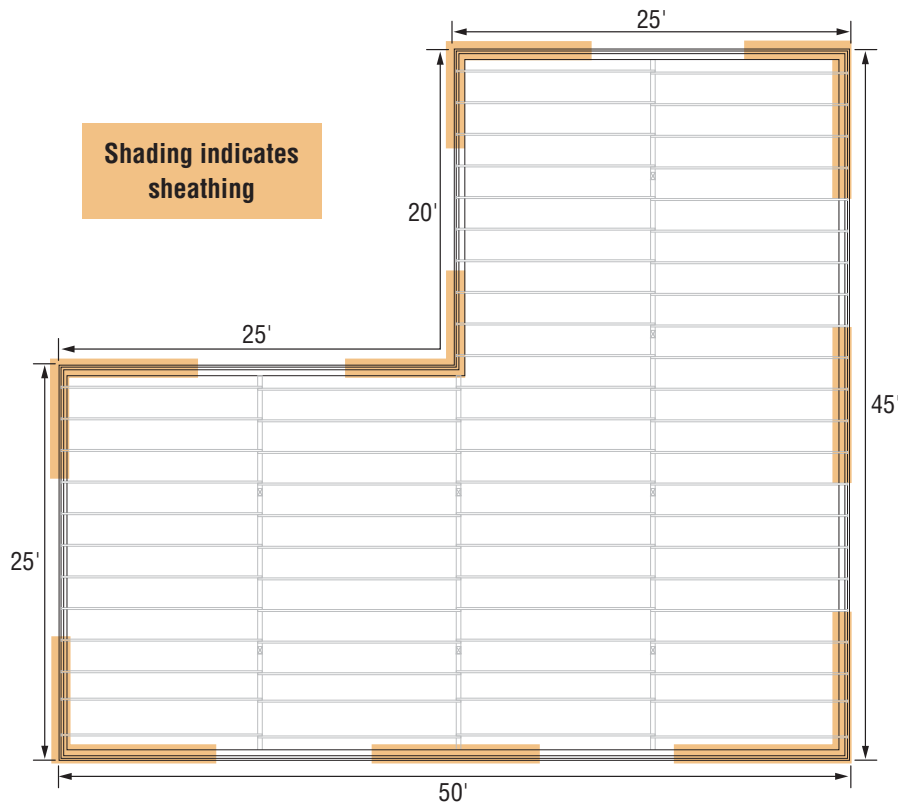

Layout worksheet provided on page 18 for your convenience.

Now that you have anchored the cripple wall to the foundation, you need to reinforce the connection between the cripple wall and the floor system. This is accomplished by installing A35 framing angles between the top plate of the cripple wall and the existing rim joist/blocking of the floor system.

Installation Details

- Framing angle: model A35
- Fasteners: (12) 8d x 1½" nails or (12) Strong-Drive® SD #9 x 1½" screws
- Spacing: 1-story; 48" o.c.
2-story; 32" o.c.
3-story; 16" o.c.

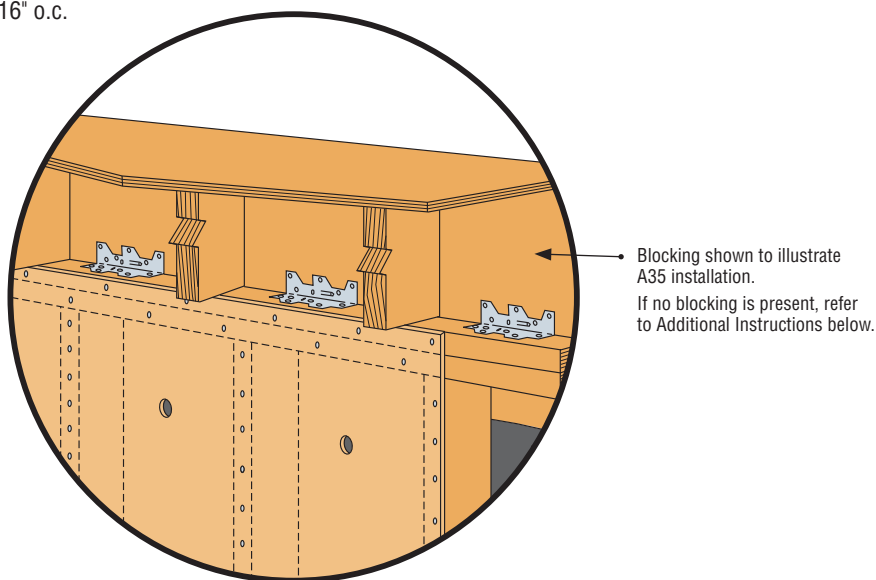

A35 Framing Angles Connect the Cripple Wall to the Floor System

Instructions

1. Starting at one corner of the house, measure and mark along the top plate of the cripple walls per the spacing requirements above. If you need to adjust this spacing to account for a break in the top plate or corner, reduce the spacing between angles.
2. Place the A35 at the corner between the top plate and the rim joist or blocking.
3. Install the nails using either a hammer or palm nailer. Install Strong-Drive® SD screws with a drill and ¼" driver attachment.

Note: A palm nailer or right-angle drill driver will greatly increase the speed and ease of installing fasteners into the cripple wall top plate.

For materials and tools required, refer to worksheet on page 19.

Additional Instructions (Installation of blocking)

1. For single-story buildings: Install new 2x solid blocking to fit between every other joist bay.
2. For two-story buildings: Install new 2x solid blocking to fit between every joist bay over brace panels. At other locations, install new 2x solid blocking to fit between every other joist bay.
3. For three-story buildings: Install new 2x solid blocking to fit between every joist bay.
4. Once blocking is installed, follow instructions above to install an A35 framing angle at every blocking location.

For more information, refer to www.strongtie.com/retrofitdetail.

Installing AC Post Caps*



In addition to securing the perimeter of your house, insuring an adequate connection between beams and posts in the middle of the floor is also recommended*. One method is the AC post cap, a unique two-piece solution that accommodates a variety of lumber sizes.

Installation Details

- Based upon the dimension of the post, select the correct model AC post cap. You will need 2 caps per post to beam connection.

Table 2 – AC Sizes and Fastener Data

Model No.	Post Width (in.)	Fasteners
AC4	3½	<i>Post:</i> (8) 16d Nails or (8) SD #10x2½" screws
AC4R	4	
AC6	5½	<i>Beam:</i> (8) 16d Nails or (8) SD #10x2½" screws
AC6R	6	

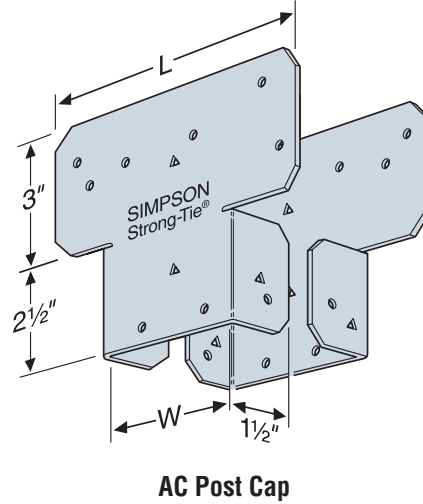

Instructions

- Place the AC onto the post to beam intersection and fill all round nail holes with 16d common nails.
- Repeat for the other side of the connection.

For materials and tools required, refer to worksheet on page 19.

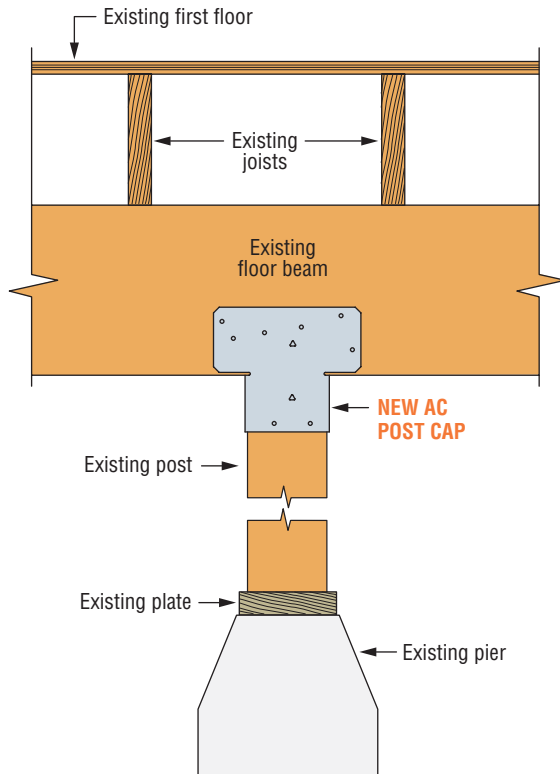

* The installation of AC post caps is not required by the IEBC, Chapter A3.

Anchor Bolt

Anchor bolts are used to secure the mudsill to the foundation. An anchor bolt is a metal rod, usually with a threaded end, that is set in concrete and is embedded in the foundation or post-installed in existing concrete (*see Titen HD*).

(Metal) Connectors

Connectors are steel components that connect the frame of the house together. Connectors are used where two pieces of framing material meet. They are designed to strengthen a house and increase its ability to resist earthquakes, high winds and other forces.

Crawl Space

Crawl space refers to the space beneath a house, typically 18" to 48" high that is supported by short wood-framed walls known as cripple walls.

Cripple Walls

Cripple walls are short wood-framed walls between the first floor and foundation. They run underneath and around the perimeter of a house. These walls are constructed on top of a house's foundation and are generally 12" to 30" high, but as high as 12' when located on a hillside. Cripple walls are vulnerable to earthquake damage and should be properly braced and bolted to the foundation.

Fasteners

Fasteners typically refer to nails, screws, bolts or anchors. Fasteners are used in conjunction with connectors to join framing materials together.

Foundation

A foundation is the block wall, concrete wall or concrete slab a house sits on.

Joist (Rim Joists, Floor Joists)

Floor joist refers to the wood spanning members that make up part of the floor system of a house. Rim joists run along the perimeter of the floor system.

Lateral Forces

Lateral forces are horizontal forces acting to move a house from side to side.

Load

Load is an engineering term that refers to the weight of the material that is to be supported. The allowable load is the maximum design load that can be imposed on a connector or an anchor.

Mudsill (Wood Sill or Sill Plate)

A mudsill is the continuous wood frame that is in contact with the foundation, supporting the floor system or cripple wall above. The mudsill should be properly anchored to the foundation.

OSB/Plywood Sheathing

OSB and plywood sheathing are panels made from wood or fiber materials that are applied to the outer studs, joists, and rafters of a house to strengthen the structure.

Post (Column)

A post is a load-bearing vertical wood member.

Retrofit

A retrofit adds additional bracing, anchoring or any improvement to a house.

Stud

A stud is a vertical wood member in the framework of a wall for supporting framing and finishing materials.

Titen HD®

The Titen HD is a high-strength screw anchor that is used to bolt the mudsill to the foundation. (*It's installed in existing concrete by drilling a hole and driving in the anchor with a wrench.*)

UFP

The Universal Foundation Plate (UFP) is a metal connector that connects the mudsill to the foundation. It is used when cripple walls are less than 3' tall or the mudsill is slightly offset from the foundation.

Uplift Forces

Uplift forces are vertical forces acting to lift a house.

Ventilation Holes

Ventilation holes are circular holes that are cut into sheathing to help prevent the wood from decay and rot. Proper ventilation is important when installing new sheathing onto the inside of cripple walls. To determine the size and placement of ventilation holes, see page 13.

Wood Shearwall

A wood shearwall is a reinforced wall in a house that has been engineered to help resist the lateral forces that are caused by an earthquake. Shearwalls are commonly built by hand on the construction site by attaching wood sheathing and holdown connectors to a section of the wood framing, and then bolting them to the foundation. Pre-manufactured shearwalls are also available, which are typically narrower than site-built walls and offer more design flexibility.

General Technical Symbols and Abbreviations

Symbol/ Terminology	Description
"	inches (in.)
'	feet (ft.)
o.c.	on center
2x	Refers to 2x4, 2x6, 2x8, etc.

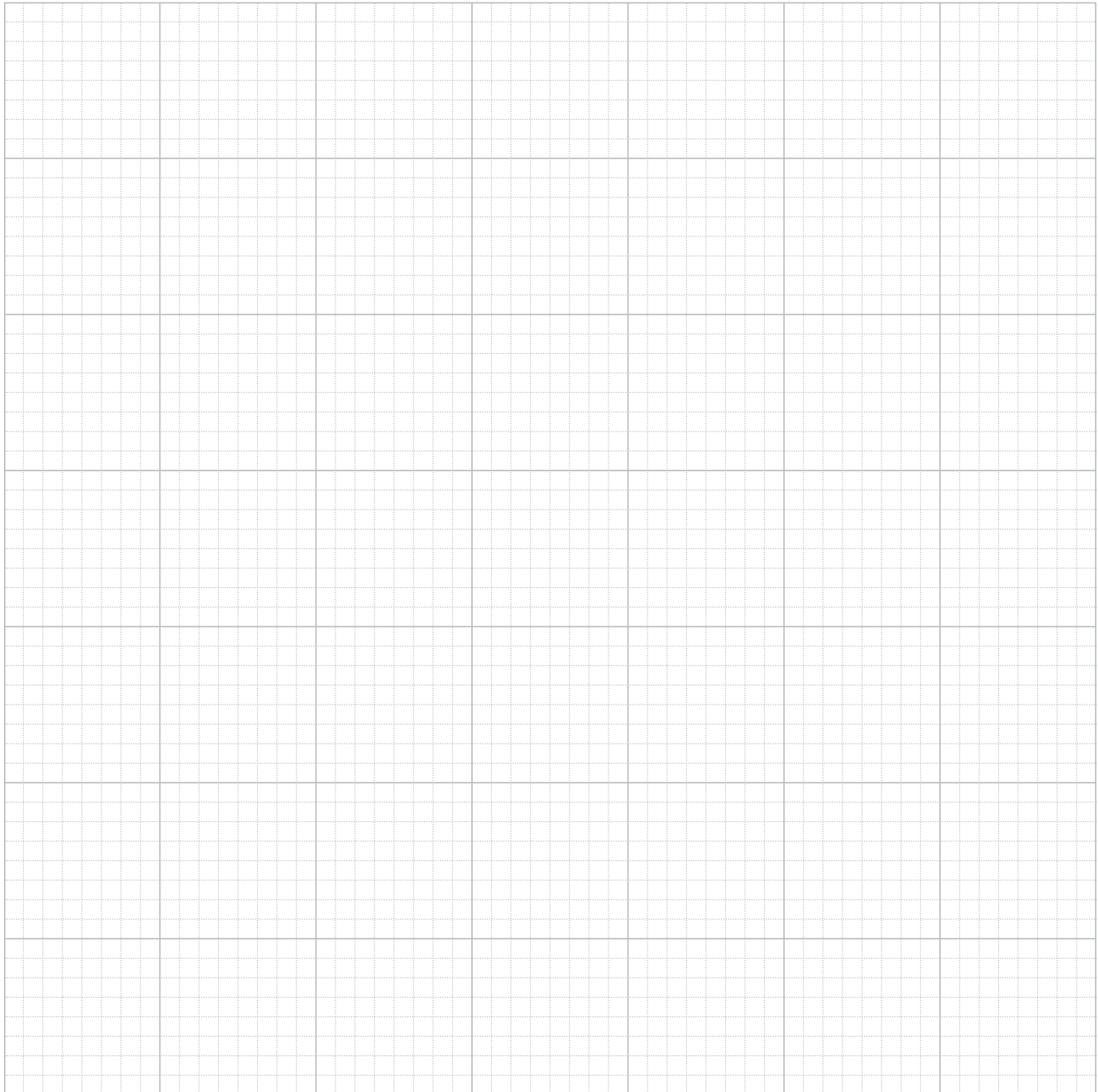

The guidelines for blocking and/or sheathing are as follows:

- One-story house: 50% of the length of each cripple wall must be sheathed.
- Two-story house: 75% of the length of each cripple wall must be sheathed
- The sheathing on any one wall can be installed in multiple runs in order to accommodate pipes, ductwork, etc. However, the length of any single run of sheathing must be equal to twice the height of the cripple wall onto which it will be installed. Example: The cripple wall is 3' tall, so no run of sheathing can be less than 6' long.
- There must be sheathing at each corner running in each direction. Once again: Multiplying the cripple wall height by 2 equals minimum length of sheathing run. Example: If your cripple wall is 3' tall, you'll need 6' of continuous sheathing at each corner running in each direction.
- No runs of sheathing can be more than 25' apart from center to center.

Using these guidelines, look at the sketch of the outline of your foundation/cripple walls and determine where you need to put sheathing to satisfy the guidelines above. Each sheathing run must begin on a stud and end on one so that the ends can be properly nailed off. Any seams between pieces of sheathing must also occur over a stud for nailing purposes. It is a good idea to go underneath your house to verify that you will be able to install sheathing per your plan.

Seismic Retrofit Worksheet



Installing the Titen HD® to Anchor the Mudsill – Page 10

Mudsill Thickness (in.)	Hole Depth in Foundation (in.)	Titen HD Model No.	Quantity Needed
		THD	
Alternate Anchorage		RFB with SET-XP® Epoxy	

Installing the Universal Foundation Plate (UFP) – Page 11

Model No.	Fasteners	Type/Part No.	Quantity Needed
UFP10 – Qty. _____		Strong-Drive® SDS ¼"x3"	5 – Included with UFP10
	Anchor Options	Titen HD® THD50500H	2 per UFP10 = _____
		Strong-Bolt™2 STB2-50514	2 per UFP10 = _____
		RFB#4x6 with SET-XP® Epoxy	2 per UFP10 = _____

Installing Blocking – Page 12

Material: 2x blocking material matching width of existing studs. Existing stud width is _____" (actual).

Stud bay width: Distance between studs. Stud bay width: _____" Total # of stud bays: _____

Total # of stud bays: _____ x stud bay width _____ / 12 = _____ LF of blocking material needed.

Total # of stud bays: _____ x 4 = _____ fasteners needed.

Suitable fasteners are Strong-Drive® SD #9x2½" screws or 10d nails.

Installing Sheathing – Page 13

Height of Cripple Wall: _____ / 12" = _____ fasteners per stud (FPS)

**If cripple wall height exceeds 48", consult a licensed design professional for evaluation.*

		Fasteners		Total Column A + Column B
		Column A	Column B (No. of Studs in Run)	
<i>Example: Run length</i>	<i>12' 6" (12.5 LF)</i>	<i>x 6 (per LF) = 12.5 x 6 = 75</i>	<i>10 studs x 2 (FPS) = 20</i>	<i>95</i>
Run A length		x 6 (per LF) = _____	_____ x _____ (FPS) = _____	
Run B length		x 6 (per LF) = _____	_____ x _____ (FPS) = _____	
Run C length		x 6 (per LF) = _____	_____ x _____ (FPS) = _____	
Run D length		x 6 (per LF) = _____	_____ x _____ (FPS) = _____	
Run E length		x 6 (per LF) = _____	_____ x _____ (FPS) = _____	
Run F length		x 6 (per LF) = _____	_____ x _____ (FPS) = _____	
Run G length		x 6 (per LF) = _____	_____ x _____ (FPS) = _____	
Run H length		x 6 (per LF) = _____	_____ x _____ (FPS) = _____	
Total LF needed			Total Fasteners	

Installing A35 Framing Angles – Page 15

Model No.	Quantity	Fasteners
A35		x 12 = _____ Total Fasteners

Suitable fasteners are Strong-Drive® SD #9x1½" screws or 8d nails.

Installing AC Post Caps – Page 16

Model No.	Quantity	Beam Fasteners	Post Fasteners
AC4 (post width 3½")		x 8 = _____	x 12 = _____
AC4R (post width 4")		x 8 = _____	x 12 = _____
AC6 (post width 5½")		x 8 = _____	x 12 = _____
AC6R (post width 6")		x 8 = _____	x 12 = _____

Suitable fasteners are Strong-Drive® SD #10x2½" screws or 16d nails.

Tool Checklist:

- | | |
|--|--|
| <input type="checkbox"/> Measuring tape | <input type="checkbox"/> Nail gun or palm nailer |
| <input type="checkbox"/> Circular saw | <input type="checkbox"/> Air compressor (and blow nozzle if necessary for adhesive installation) |
| <input type="checkbox"/> Rotohammer drill | <input type="checkbox"/> Chalk line |
| <input type="checkbox"/> ½" and/or ⅝" Carbide-tipped drill bit | <input type="checkbox"/> 3" Hole saw drill bit |
| <input type="checkbox"/> Hand socket wrench or impact driver | <input type="checkbox"/> ⅝" or ¾" Carbide-tipped drill bit (adhesive installation) |
| <input type="checkbox"/> ¾" and/or 1⅝" socket | <input type="checkbox"/> ETB brush (adhesive installation) |
| <input type="checkbox"/> Drill with ⅝" and ¼" driver attachments | <input type="checkbox"/> Caulking gun or EDT22S dispensing tool (adhesive installation) |
| <input type="checkbox"/> Hammer | |

To learn more about earthquakes and home retrofit solutions, visit www.strongtie.com and click on "For Your Home."



Every day we work hard to earn your business, blending the talents of our people with the quality of our products and services to exceed your expectations. This is our pledge to you.



Wood Construction Connectors

Includes specifications and installation instructions on wood-to-wood and wood-to-concrete structural connectors. Includes load tables and material specifications.

Anchoring and Fastening Systems for Concrete and Masonry

Includes application information, specifications and load values for adhesive and mechanical anchors, gas- and powder-actuated fastening systems and carbide drill bits.

Fastening Systems

The 195-page catalogue showcases our entire line of structural, corrosion-resistant, stainless-steel and collated fasteners as well as our Quik Drive® auto-feed screw fastening systems.

High Wind-Resistant Structural Connectors

For builders and homeowners on retrofitting and new construction in high wind areas.

Deck Framing Connection Guide

Helps deck builders, inspectors and do-it-yourselfers build a code-compliant, safe deck. The guide covers the critical areas of deck construction to help ensure decks are properly fastened and secured, and meet the required design loads.

Do-It-Yourself Connectors Catalog

Suitable for a wide range of capabilities, this catalog includes ideas for home projects. This catalog includes connectors for decks, patio covers, fences and garage organization.

Free Simpson Strong-Tie® Literature CD-ROM

Our Literature CD-ROM features our latest Connectors, Lateral Systems, Fastening Systems and Anchor Systems literature.

In addition to the publications shown above, Simpson Strong-Tie maintains an extensive library of literature, providing information on a wide variety of subjects. You can access the library by visiting www.strongtie.com/tech-bulletins or you can call 800-999-5099 and have publications mailed to you.

800-999-5099
www.strongtie.com

Home Office

5956 W. Las Positas Blvd.
Pleasanton, CA 94588
Tel: 925/560-9000
Fax: 925/847-1603

Northwest USA

5151 S. Airport Way
Stockton, CA 95206
Tel: 209/234-7775
Fax: 209/234-3868

Southwest USA

12246 Holly Street
Riverside, CA 92509
Tel: 714/871-8373
Fax: 951/369-2889

Northeast USA

2600 International Street
Columbus, OH 43228
Tel: 614/876-8060
Fax: 614/876-0636

Southeast USA

2221 Country Lane
McKinney, TX 75069
Tel: 972/542-0326
Fax: 972/542-5379

Eastern Canada

5 Kenview Boulevard
Brampton, ON L6T 5G5
Tel: 905/458-5538
Fax: 905/458-7274

Western Canada

11476 Kingston Street
Maple Ridge, B.C. V2X 0Y5
Tel: 604/465-0296
Fax: 604/465-0297

Kent Specials Factory

22035 W. Valley Hwy.
Kent, WA 98032
Toll Free: 877/564-2041

Eagan Warehouse & Specials Factory

3711 Kennebec Dr., Ste 700
Eagan, Minnesota 55122
Tel: 651/681-2061
Fax: 651/681-2046

Distribution Centers

Enfield, CT;
High Point, NC;
Jacksonville, FL;
Jessup, MD;
Langley, B.C.;
Ontario, CA

INTERNATIONAL FACILITIES

Please visit our website for address and contact information for our European facilities.