

CITY OF WHITTIER WATER UTILITY STANDARD SPECIFICATIONS



**CITY OF WHITTIER
WHITTIER UTILITY AUTHORITY**

APPROVED: FEBRUARY 7, 2017

REVISED: JUNE 22, 2023

**13230 PENN STREET
WHITTIER, CA 90602
(562) 567-9500**

CITY OF WHITTIER

WATER UTILITY

STANDARD

SPECIFICATIONS

**PUBLIC WORKS DEPARTMENT
WATER DIVISION
13230 PENN STREET
WHITTIER, CA 90602**

RECOMMENDED BY:



RAYMOND CORDERO
WATER MANAGER

June 22, 2023
DATE

APPROVED BY:

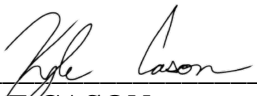

KYLE CASON
DIRECTOR OF PUBLIC WORKS

June 22, 2023
DATE

UPDATED BY:



RAUL FLORE
ENGINEERING MANAGER

June 22, 2023
DATE

INTRODUCTION

These Standard Specifications are to be used as a guide by Private Engineers and Contractors in the design and installation of additions or modifications to the City of Whittier's Public Water System.

It is the intent that these Standard Specifications will provide uniformity in materials and installation of piping, valves, fire hydrants, service laterals and other appurtenant equipment. The Standard Specifications will also provide for construction methods and controls to be used by Contractors to construct, pressure test, chlorinate and place into service domestic water systems in the City of Whittier.

CITY OF WHITTIER WHITTIER UTILITY AUTHORITY

WATER UTILITY STANDARD SPECIFICATIONS

TABLE OF CONTENTS

SECTION 1 GENERAL PROVISIONS

- 1-01 Plans and Specifications
- 1-02 Definitions
- 1-03 Abbreviations
- 1-04 Licenses, Permits, and Fees
- 1-05 Inspection
- 1-06 Guarantee

SECTION 2 MATERIALS

- 2-00 General
- 2-01 Ductile Iron Pipe
- 2-02 Polyvinyl Chloride Pipe
- 2-03 Thrust Restraining Materials
- 2-04 Main Line Valves
- 2-05 Air and Vacuum, Air Release and Combination Air Valves
- 2-06 Fire Hydrants
- 2-07 Main Line Pipe Fittings
- 2-08 Sleeves and Clamps
- 2-09 Main Line Couplings
- 2-10 Service Lateral
- 2-11 Installation Small Meters
- 2-12 Shop Drawing and Material Submittals
- 2-13 Painting-Above Ground Installations
- 2-14 Access to Manufacturing and Test Facilities

SECTION 3 CONSTRUCTION METHODS AND CONTROL

- 3-01 Inspection
- 3-02 Pre-Construction Details
- 3-03 Removals and Trench Excavation
- 3-04 Connection to Existing Facilities
- 3-05 Laying of Ductile Iron Pipe Water Main

- 3-06 Laying of PVC Pipe Water Main
- 3-07 Service Laterals
- 3-08 Pipe Bedding and Backfilling of Trench
- 3-09 Repaving and Finishing
- 3-10 Testing, Disinfection, and Flushing
- 3-11 Special Conditions
- 3-12 Dedication of Improvements to the City
- 3-13 As – Built Drawings

SECTION 4 LARGE SERVICES AND FIRE LINES

- 4-01 General
- 4-02 Design
- 4-03 Fees
- 4-04 Construction and Inspection
- 4-05 Easements
- 4-06 Meters
- 4-07 Vault Installations
- 4-08 Thrust Restraint - Vault Installation
- 4-09 Painting - Above Ground Installations
- 4-10 Aesthetics - Above Ground Installations

SECTION 5 BACKFLOW PREVENTION

- 5-01 Backflow Protection
- 5-02 Fire Line Assembly

SECTION 6 STANDARD DRAWINGS

WATER UTILITY STANDARD DRAWINGS

W-601	1" WATER SERVICE INSTALLATION
W-602	2" WATER SERVICE INSTALLATION
W-603	3" THROUGH 8" METER LATERAL INSTALLATION
W-604	ABOVE GROUND METER INSTALLATION 3" & LARGER
W-605	UNDER GROUND METER INSTALLATION 3" & LARGER
W-606	FIRE LINE DOUBLE CHECK DETECTOR ASSEMBLY
W-610	REDUCED PRESSURE BACKFLOW PREVENTER ¾" THROUGH 2"
W-611	REDUCED PRESSURE BACKFLOW PREVENTER- LARGE DOMESTIC
W-615	2 ½" CITY PROVIDED CONSTRUCTION METER
W-616	FIRE HYDRANT GUARD POST
W-617	STANDARD FIRE HYDRANT INSTALLATION
W-620	STANDARD VALVE BOX ASSEMBLY
W-621	VALVE CAN ADJUSTING
W-625	WATER METER BOX ¾" THROUGH 2"

W-626	STANDARD VAULT INSTALLATION
W-630	AUTOMATIC AIR RELEASE ASSEMBLY
W-635	TYPICAL THRUST BLOCK DETAILS 4" TO 12" DIA. FITTINGS
W-636	RESTRAINED JOINT DETAIL
W-640	SEWER AND WATER SEPARATION AND CROSSING REQUIREMENTS
W-641	WATER MAIN OFFSET/SIPHON
W-645	2" AND SMALLER SERVICE LATERAL ABANDONMENT
W-646	3" THROUGH 12" PIPELINE ABANDONMENT
W-647	TYPICAL TRENCH DETAIL
W-648	WARNING IDENTIFICATION AND TRACER WIRE INSTALLATION
W-649	CONNECTION TO EXISTING WATER MAIN
W-650	3" AND ABOVE GROUND METER AND BACKFLOW DETAIL
W-652	SAMPLING STATION DETAIL

SECTION 1 - GENERAL PROVISIONS

1-01 PLANS AND SPECIFICATIONS

Construction of all water system improvements intended to be dedicated to the City of Whittier's Public Water System will be governed by plans and specifications approved by the Water Services. All plans and specifications must be prepared by, or under the supervision of a current registered civil engineer licensed to practice in the State of California. All work shall be subject to fees as provided for in the City's Water Rates, Rules and Regulations and shall be inspected by the Utility to ensure conformity to these specifications.

In cases of conflict of information, the following documents will have precedence in the order listed:

1. Permits and licenses from affected agencies issued for the improvements.
2. Special provisions for the improvements.
3. Construction plans for the improvements
4. City of Whittier/Whittier Utility Authority (WUA) Water Utility Standard Specifications (WUA WUSS)
5. Standard Specifications for Public Works Construction (SSPWC), "Green Book".
6. Manufacturer's recommendations of product use and installation

Conflicts and discrepancies noted by the Contractor shall be brought to the attention of the Engineer. The Engineer will review the conflicts or discrepancies and determine the appropriate course of action to follow, if any. Unless otherwise determined by the Engineer, the most stringent/restricted condition shall govern over all. Contractor/Developer shall check with zoning code and/or local ordinances for special requirements and color schemes on all above ground facilities.

Provisions of reference specifications noted in these specifications and plans shall have the same effect as if written herein, unless expressly modified by these specifications. Any reference specification in the absence of designation to the contrary, shall be understood to refer to the latest revision at the time of the beginning of work.

1-02 DEFINITIONS

Whenever the following terms or corresponding pronouns are used in these specifications or plans, the intent and meaning shall be interpreted as follows:

a.	City:	The City of Whittier, California.
b.	Engineer:	The City Engineer or his/her authorized representative.
c.	Utility:	The Whittier Utility Authority (WUA) or its authorized representative.
d.	Developer:	The person or organization having legal responsibility for construction of water systems in conjunction with development of property.
e.	Contractor:	The agent of the developer or independent contractor who furnishes labor, material, equipment, method, etc. to perform the requirements of these specifications in the construction of water systems.
f.	Superintendent:	The field representative of the Contractor, present on the job site at all times during work, who is authorized to receive and fulfill instructions from the City.
g.	Private Engineer:	The agent of the developer or independent engineer who has responsibility for the design and drawing of construction documents.
h.	Or approved equal:	An equivalent product to that specified in these standard specifications, approved by the Utility before beginning of construction. No approved equal product is intended, unless so stated in these standard specifications.
i.	Drawings:	The words "DRAWINGS" or "CONTRACT DRAWINGS" or "PLANS" shall mean those drawings accompanying the specifications which show the location, nature, extent and form of the work, together with applicable details.

1-03 ABBREVIATIONS

Whenever the following abbreviations are used in these specifications, the meaning shall be interpreted as follows:

ASTM:	American Society for Testing and Materials
AWWA:	American Water Works Association
ANSI:	American National Standards
DIPRA:	Ductile Iron Pipe Research Association
CAL-OSHA:	California Occupational Safety and Health Administration
SSPC:	Steel Structures Painting Council
SSPWC:	Standard Specifications for Public Works Construction. (Green Book)- Latest Edition
CBC:	California Building Code
CFC:	California Fire Code
CPC:	California Plumbing Code
WUSS:	Water Utility Standard Specifications of WHITTIER UTILITY AUTHORITY (WUA)
NFPA:	National Fire Protection Association
NSF:	National Sanitation Foundation
UL:	Underwriters Laboratories

1-04 LICENSES, PERMITS, AND FEES

The contractor shall have a Class “C-34” Pipeline or Class “A” General Engineering Contractor’s License valid in the State of California and shall meet all the applicable requirements of the City of Whittier Municipal Code.

The Contractor and/or Developer shall obtain all necessary permits, licenses, or

agreements required by any legally constituted agencies, pay all fees, and give all necessary notices required for the construction of the work.

Prior to beginning any work, an excavation permit from the Engineering Division, including any required deposits and bonds, are required for excavation in the public right-of-way within the City of Whittier. Pavement repair shall be made by a licensed paving contractor and shall conform to these Specifications and the Greenbook. The contractor is responsible for all costs associated with the work performed, including any corrections or repairs. In the event the Contractor fails to complete the work or make any required corrections/repairs, any and all costs incurred by the City will be deducted from the deposit or the surety will be billed for these expenses. Said deposit or bond shall be retained by the City for payment and for material and labor.

Before the Contractor or any subcontractor performs work, it shall be necessary for each company to obtain a business license from the City of Whittier Business License Division of the City Clerk Department.

1-05 INSPECTION

The construction of any water system improvement intended for dedication to the City and used for public water service shall be subject to inspection and approval/acceptance by the Director of Public Works. Such inspection will assure that all phases of the work are in compliance with these Specifications. The City's designated inspector will be the representative of the Director of Public Works and shall coordinate the various responsibilities of the Utility throughout the work. Contractor shall schedule pre-construction meeting with Utility a minimum of 48 hours prior to construction. Inspection costs will be paid by the Developer at the rate or fee prescribed by the City Council resolution.

The inspector shall have access to the work area and shall be furnished every reasonable facility for ascertaining full knowledge of the progress, material, and workmanship used to complete the work. The Contractor shall provide at least 24 hours advance notice of major phases of construction for purposes of inspection. All material shall be approved prior to placement and all water system works shall be visually inspected prior to backfilling.

The Engineer shall have the authority to suspend the work wholly, or in part, for such time as it may deem necessary due to failure of the Contractor to perform any provisions of the plans or specifications. The work may only continue when the defective material or construction method is recognized as corrected by the Engineer.

1-06 GUARANTEE

The Contractor shall guarantee the work against defective material or workmanship for a period of one year from the date of completion of the contract and/or acceptance of the work by the City. Damage due to acts of God or from sabotage and/or vandalism is specifically exempted from the guarantee. When defective materials and/or workmanship are discovered which requires repairs to be made under this guarantee, all such works shall be done by the Contractor at his own expense and shall begin within five working days after written notice of such defects has been given to him/her by the City. Should the Contractor fail to repair such defective materials or workmanship within five working days thereafter, the City may cause the necessary repairs to be made and charge the Contractor with the actual cost of all labor and materials required.

In emergencies demanding immediate attention, the City shall have the right to repair the defects and charge the contractor with the actual cost of all labor and materials required. Any repair works preformed as herein specified shall be done under the provisions of the original work specifications.

SECTION 2- MATERIALS

2-00 GENERAL

All materials and equipment installed in City of Whittier's water system shall meet all state and federal standards, as well as standards developed by nationally recognized organizations such as AWWA, ANSI and NSF. In order to protect human health, all materials, chemicals, lubricants, and products in contact with drinking water shall be tested and certified as meeting NSF/ANSI standard 60 (Drinking Water Treatment Chemicals-Health Effects) and ANSI/NSF Standard 61 (Drinking Water System Components-Health Effects).

All materials are required to be certified as lead-free by NSF or other ANSI accredited certifier per SB 1334.

2-00.01 PROTECTION OF METAL SURFACES

All buried metal surfaces on valves, flanges, bolts, nuts, tie-rods, tum buckles, restraint devices, couplings and other appurtenances in contact with the earth and backfill materials shall be coated with a minimum 30 mils of JS160H Mastic manufactured by Protecto Wrap Co. 30 mils of Bituminous Mastic 50-HT by Utility Coating Company, or approved equal. In addition to this coating, all metal surfaces as previously described, shall be encased in 8 mil polyethylene protective wrapping and tape wrapped to the pipe barrel in accordance with AWWA C-105 and Sections 2-01.04 and 3-11.03 of the WUSS.

2-01 DUCTILE IRON PIPE

2-01.01 GENERAL

All DIP and fittings shall be pressure class 350 (unless otherwise noted on the plans), factory cement mortar lined with seal coat in accordance with AWWA Standard C104, and coated with bituminous material as specified in C151, unless otherwise specified. Size four-inch (4") through twelve-inch (12") shall be Pressure Class 350, unless otherwise specified. Pipes larger than twelve-inch (12") shall be Thickness Class 51. Special order pipe sizes, three-inch (3"), ten-inch (10"), and fourteen-inch (14"), are not allowed unless otherwise authorized by Utility. The contractor shall furnish the pipe certification.

Pipe shall be manufactured by US Pipe, McWane, American, or approved equal.

2-01.02 PIPE JOINTS

Ductile iron pipe shall be furnished in eighteen-foot (18') or twenty-foot (20') nominal laying lengths and shall have a push-on joint employing a single rubber gasket in accordance with AWWA Standard C111, as manufactured by "TYTON®" from U.S Pipe, "FASTITE®" from AMERICAN Pipe.

Where restrained joints are indicated on the Drawings, push-on joints shall be restrained in accordance with the requirements of Section 2-03.

2-01.03 COATING AND LINING

All pipe shall have the interior cement-mortar lined with a seal coat in accordance with AWWA Standard C104, and the outside coated with a bituminous material as specified in AWWA Standard C151.

2-01.04 POLYETHYLENE PROTECTIVE WRAPPING

Polyethylene protective wrapping ("Polywrap") shall conform to the requirements of ANSI/AWWA C105/A21.5 and be eight (8) mil thick tubing of virgin polyethylene, or four (4) mil thick high-density, cross-laminated (HDCL) polyethylene. The color shall be (a) natural (where exposure to sunlight will be less than 48 hours); or (b) black, containing 2.0 to 2.5% well dispersed carbon black with stabilizers (where exposure to sunlight may be up to 10 days). Tubing shall be taped and secured with general purpose polyethylene tape, 2 inches wide and 10 mils thick. See Section 3-11.03 for more information.

APPROVED POLYETHYLENE PROTECTIVE WRAPPING

Protecto Wrap Co.	JS160H
Utility Coating Company	50-HT
Dupont	20 Series
Northtown Company	Polywrap

APPROVED POLYETHYLENE PROTECTIVE WRAPPING TAPE

Scotchrap	No. 50
Plicoflex	No. 340
Protecto Wrap	No. 200
Polyken	No. 900

2-02 POLYVINYL CHLORIDE PIPE

At the sole discretion of the Utility, polyvinyl chloride (PVC) pipe material for

distribution main may be used. PVC Pipe shall be Pressure Class 235 (DR 18), unless otherwise required by the Utility, conforming to the requirements of AWWA Standard C900 “Polyvinyl Chloride (PVC) Pressure Pipe and Fabricated Fittings, 4 inch through 12 inch, for Water Transmission and Distribution” or C905 “Polyvinyl Chloride (PVC) Pressure Pipe and Fabricated Fittings, 14 inch Through 48 inch” for pipe sizes larger than 12 inches in diameter.

The pipe shall have integral bell joints, complete with a gasket installed by the manufacturer. The Contractor shall furnish certification that all PVC pipe supplied for this project has been manufactured in compliance with all requirements of AWWA C900.

Material used to produce the pipe shall be made from Class 12454-A or B virgin compounds as defined in ASTM D 1784, with an established hydrostatic design basis rating of 4,000 psi for water at 73.4°F (23°C). Potable water pipe shall either be colored blue or white.

Pipe shall be manufactured by PW Pipe, J-M Manufacturing, or approved equal.

2-02.01 MARKINGS

PVC Pipe shall be legible and permanently marked in ink with the following information.

- Manufacturer and Trade Name
- Nominal Size and DR Rating/Pressure Class
- Hydrostatic Proof Test Pressure
- [NSF-61]
- Manufacturing Date Code

2-02.2 FITTINGS FOR PVC MAIN LINE

Main line PVC pipe fittings shall be as called for on the construction plans. All fittings shall be ductile iron fittings per Section 2-01.

2-02.3 PIPE JOINTS

PVC shall be furnished in 20 foot nominal laying lengths and have bell-end push-on joints employing a single elastomeric gasket in accordance with AWWA Standard C900 and C905.

2-02.4 TRACER WIRE AND WARNING TAPE

The tracer wire and warning identification tape shall be installed per Section Drawing W-648. Tracer wire shall be Copperhead Industries Model #10CCS High Strength 600# Break Load with Locking SnakeBite Tracer Wire Connectors insulated copper, blue in color, or approved equal.

Warning tape shall be 6-inch wide, blue in color and marked “Caution Water Line Below”.

2-03 THRUST RESTRAINING MATERIALS

All mechanical thrust restraining devices shall be ductile iron. All devices shall withstand a working pressure of at least 250 psi with a minimum safety factor of 2.

2-03.1 MECHANICAL JOINTS

Restraining devices for mechanical joint fittings shall be incorporated with the design of a follower gland and grip ring restraining mechanism that utilizes contact with entire circumference of pipe for restraint. The ring shall flex to accommodate deflection allowed in a mechanical joint after burial. If the mechanism is not available in the specified O.D., a similar wedge action restraint utilizing partial contact with circumference of pipe shall be used. Glands shall be manufactured of ductile iron conforming to ASTM A536.

APPROVED MECHANICAL JOINT RESTRAINING FOR 4”-12”

EBAA IRON, Inc.	Megalug Series 1100(DIP), 2000 (PVC)
Ford	Uni-Flange Block Buster™ 1300
Romac Industries, Inc.	GripRing™

APPROVED MECHANICAL JOINT RESTRAINING FOR 14”-48”

EBAA IRON, Inc.	Megalug Series 1100(DIP), 2000 (PVC)
Ford Meter Box Co., Inc.	Uni-Flange Block Buster™ 1300
Romac Industries, Inc.	Romagrip™
Smith-Blair	Cam-Lock™ (PVC or DIP)

2-03.2 FLANGED ADAPTERS

Flange adapters shall be fully restrained wedge activated type with a minimum working pressure of 250 psi and a safety factor of 2. Outside and inside surfaces of flange adapters shall be epoxy coated.

Flange adapters shall be manufactured from ductile iron per ASTM A536 and shall have bolt circles and bolt holes to meet ANSI B16.1 – Class 125 or Class 250 if required and shown on the plans.

APPROVED FLANGE ADAPTERS

EBAA IRON, Inc.	Megaflange Series 2100
Ford	Uni-Flange 900- Adapter Flange (PVC)
	Uni-Flange 400- Adapter Flange (DIP)
Romac Industries, Inc.	Field Flange (DIP)
Smith-Blair	Flange-Lock

2-03.3 PUSH-ON PIPE JOINTS

Where restrained joints are indicated on the plans, push-on TYTON JOINT® pipe shall be restrained with “FIELD LOK” gaskets as manufactured by U.S Pipe, and Blue Brute™ pipe shall be restrained with “Eagle Loc” internal joint restraints as manufactured by JM Eagle or approved equal.

The first two full pipe joints upstream and downstream of tie-ins, confluences, bends, and valves shall be restrained. Restrained joint pipe is an acceptable option for restraint of push-on joint pipe. Restrained push-on joint pipe and fittings shall be capable of being deflected after assembly.

APPROVED INTERNAL RESTRAINED FOR 4”-12” DIP

US Pipe	FIELD LOK® 350 Gasket
US Pipe	TR FLEX®
McWane Pipe	Sure Stop 350 Gasket

APPROVED INTERNAL RESTRAINED FOR 4”-12” PVC

US Pipe	Series PV MJ FIELD LOK® Gasket
JM Eagle	EAGLE LOC

2-03.4 CONCRETE

Thrust restraints are to be installed in lieu of concrete thrust blocks. Concrete thrust blocks must be preapproved before installation. Calculation must be submitted.

Thrust blocks, if approved, shall be Class 520-C-2500 concrete. Pressure testing up against thrust blocks is not allowed until after 48 hours of cure time. Concrete chemical admixtures are not allowed.

2-04 MAIN LINE VALVES

2-04.1 GENERAL

For water mains, resilient seated gate valves shall be used for 4 to 12 inches and butterfly valves for 14 inches and larger lines. All ferrous components of valves shall be ductile iron and coated with fusion bonded epoxy.

Valves shall be ductile iron body; fusion bonded epoxy lined, non-rising stem butterfly or fully encapsulated resilient wedge disk type gate valve and shall not have more than two internal moving parts. All valves shall open by turning the wrench nut counter-clockwise. Operating nut for butterfly valves shall be placed at the north or east side of the water line.

When required, above ground installations shall be resilient seat/wedge disk type valves with outside screw and yoke.

All bronze parts shall contain no more than 7% zinc, nor more than 2% aluminum. Stems shall be low zinc bronze, and equipped with a 2-inch operating nut Conforming to AWWA C515. The valve manufacturer shall employ a positive physical means of indicating the specified stem material to insure ready recognition during inspection.

The bolts and nuts on the bonnet shall be stainless steel type 316 with an anti-seize lubricant unless otherwise noted.

The ductile iron interior and exterior of all valves shall be protected with 10 mils (nominal) fusion bonded epoxy. Coating shall conform with AWWA Standard C213 and C550, and shall be certified to NSF 61.

For above ground or vault installation, exterior coating to valves shall be as per Section 2-13 for coating on above ground or vault installation.

Resilient wedge type valves with a flanged end may be used as "tapping valves".

All valves shall be provided with an epoxy coated stem extension if depth of valve nut exceeds 4 feet. All valve extensions shall be centered in the valve well by use of a guide and shall operate freely without binding after installation.

2-04.2 GATE VALVES

Gate valves 12" and below shall conform to the requirements of AWWA Standard C509 Resilient-Seated Gate Valves. Gate Valves over 12" in size shall conform to the requirements of AWWA Standard C515 Reduced-Wall, Resilient Seated Gate Valves.

All gate valves shall be ductile-iron body equipped with double O-ring stem seals. All gate valves shall have EPDM O-rings, and stainless steel bolts.

APPROVED GATE VALVE MANUFACTURERS

Mueller	A-2362
Clow	4067
US Pipe	A-USP2-E381

2-04.3 BUTTERFLY VALVES

Butterfly valves shall conform to the requirements of AWWA Standard C504. Valves shall have a minimum working differential pressure across the valve disc of 150 psi for class 150B valves and 250 psi for class 250B valves. Valves shall be flanged short-body or restrained mechanical joint as indicated per the Construction Drawings. Flanges for both Valve Class 150B and 250B shall be drilled per ANSI B16.1, 125-pound standard bolt pattern. Valves shall be designed for buried installation.

Component	Material	Specifications
Body	Ductile Iron	ASTM A-536, Grade 65-45-12
Valve Shaft	Stainless Steel	Type 304 or Type 316
Exposed body, cap screws, bolts and nuts including squeeze-pins	Stainless Steel	ASTM A-276, Type 316
Disc with Stainless Steel Edge type	Ductile Iron	ASTM A-536, Grade 65-45-12
Valve Seat	EPDM Rubber	ASTMD-412
O-Rings	Synthetic Rubber	ASTMD-2000

Valve seat material shall be peroxide cured EPDM rubber seat and shall be fastened integrally with the valve body. The valve disc shall be furnished with a stainless steel seating edge to mate with the rubber seat in the valve body. Valves with the seat located on the disc shall not be accepted.

The ductile iron interior and exterior shall be factory coated with NSF 61 approved 16 mils DFT high solids 2 part epoxy of not less than 65% conforming to AWWA standard C550 (Amerlock® 400, Tnemec 141, or approved equal).

Valve operators shall be the manual type. Valve actuator shall be supplied and installed on the valve by the valve manufacturer. Gear actuators shall be for buried service applications and shall come furnished with a standard 2" AWWA operating nut. Spring pins shall be solid pins and not hollow. The operators shall be of travelling nut type with adjustable stops for valves smaller than 24" in size. The operator for valves 24" and larger shall be worm gear type. The actuator shall be capable of withstanding 300 ft-lb (for worm

gear) and 450 ft-lb (for travel nut gear) at the stops. The actuator shall be sized for bi-directional maximum pressures and flow rate per AWWA valve classification 150B (250B when specified). All external bolts on the actuator shall be 316 stainless steel. The operator shall be of the size required for opening and closing the valve in accordance with AWWA C-504. All valve operators shall be factory packed with grease, fully gasketed and sealed for permanent installation and operation.

Factory signed and dated affidavit of compliance shall accompany all submittals. Affidavits shall include "holiday free" paint, actuator stops compliance of 450 foot pounds, proof of design per AWWA C504 latest version for valves and actuator, and bi-directional seat leak test. Signatures of agents or distributors of the factory will not be accepted.

All valves shall be seat leak tested at the rated pressure in both directions by the valve manufacturer and shall be witnessed by an authorized City agent. The valves shall be tested within 30 miles of City limits and shall be tested with the valve flanges in the vertical direction (the same orientation as the installation orientation). The seat leakage test shall be performed in compliance with AWWA C504 latest edition. Signed and dated records of compliance shall be provided to the City. Any valves which might fail to meet the seat leak test shall be expeditiously and professionally remedied at the valve manufacturer's expense. All subsequent re-testing for City witness leak testing approval shall be the responsibility of the manufacturer. Should the City deem that re-testing becomes excessive; the City shall reserve the right to require manufacturer reimbursement for its agent's costs associated with the re-testing.

APPROVED BUTTERFLY VALVE MANUFACTURERS

Mueller

B-3211, Lineseal XP2

2-04.4 END CONNECTIONS & GASKET MATERIAL

Valves shall have mechanical joints or flanged ends, or a combination of both. Gaskets shall conform to the requirements of Section 2-07.4 of these specifications.

Unless otherwise shown on plans, all valves installed at fittings shall be flanged by mechanical ends, with the flange abutting the fitting.

2-05 AIR AND VACUUM, AIR RELEASE, AND COMBINATION AIR VALVES

Air and Vacuum, Air Release and Combination Air Valves shall conform to AWWA C512 and be designed for a working pressure of 150 psi, unless otherwise specified. Float, linkage and all internal parts shall be 8-18 stainless steel. Interior coating for cast iron body shall be NSF 61 approved fusion bonded epoxy. Valves shall be APCO as manufactured by Valve and Primer Corporation, Crispin by Multiplex Manufacturing Co., Cla-Val, or approved equal.

APPROVED AIR/VACUUM MANUFACTURERS

APCO	Series 140
Crispin	Series AL
Cla-Val	Series 35

APPROVED AIR RELEASE MANUFACTURERS

APCO	50/200A
Crispin	Series AR/PL
Cla-Val	Series 34

APPROVED COMBINATION AIR MANUFACTURERS

Val-Matic	201C Series
Crispin	Series UL
Cla-Val	Series 36

2-06 FIRE HYDRANTS

2-06.1 GENERAL

Fire hydrants shall be of the wet-barrel type, epoxy coated, brass body, conforming to AWWA C503, and as supplemented herein. The Engineer may require a break-off check valve with the wet-barrel type due to location, terrain, drainage system, and/or system pressure.

2-06.2 MATERIALS AND PARTS

Fire hydrants shall have two 2 1/2-inch hose outlets and one 4-inch pumper outlet. Outlet threads shall conform to ANSI-B26 "National Standard Fire Hose Coupling Screw Threads".

Fire hydrants shall be furnished with a pentagon shaped operating nut 1-1/8 inch per side, and opening shall be counterclockwise. Fire hydrants shall be

furnished with hollow break off bolts or an equivalent break off device at the ground level flange.

Fire hydrants shall be equipped with plastic outlet nozzle caps attached to the body of the fire hydrant with non-kinking electro-galvanized steel chains and fitted with appropriate neoprene rubber gaskets.

All fire hydrant burys shall be cast iron, asphalt coated and cement lined. Fire hydrant burys shall be provided with a Mechanical Joint-end at the shoe.

Wet barrel type fire hydrants shall have a nominal six-inch (6") base flange with a six-hole bolt pattern. All internal working parts, including stem, shall be bronze containing no more than seven percent (7%) zinc or two percent (2%) aluminum or 316 stainless steel. Hydrant must be painted with Whittier approved color blue coating. This coating must be applied by the hydrant manufacturer at the point of assembly. Manufacturer fire hydrant color below.

APPROVED FIRE HYDRANT MANUFACTURERS

Clow:

Fire Hydrant #2050	Color: 215002100102WB9
Fire Hydrant #2060	Color: 216004100102WB9
Fire Hydrant #2065	Color: 216506100102WB9

James Jones Co.:

J-3700	Color: Vista Blue Wave #Q13-28T	Catalog No: J3700R Z73
J-3765	Color: Vista Blue Wave #Q13-28T	Catalog No: J3765R Z73

2-07 MAIN LINE PIPE FITTINGS

2-07.1 GENERAL

Main line pipe fittings shall conform to the requirements of AWWA Standard C110, "Ductile Iron and Gray-Iron Fittings, 3-inch Through 48-inch, for Water and Other Liquids".

Short body type fittings conforming to AWWA Standard C153 may be used for sizes 4-inch through 24-inch.

All fittings shall be made of ductile iron. Fittings up to 24-inch size shall be 350 psi pressure ratings, fittings between 30-inch and 48-inch size shall be 250 psi pressure rating, and fittings for 54-inch to 64-inch size shall be 150 psi pressure rating. Fittings shall be cement mortar lined in accordance with AWWA Standard C104, "Cement Mortar Lining for Ductile-Iron Pipe and

Fittings for Water". Fittings shall be coated with a bituminous material as specified in AWWA Standard C151.

2-07.2 MECHANICAL JOINTS

Mechanical Joints shall conform to the requirements of AWWA Standard C111 "Rubber-Gasket Joint for Ductile Iron Pressure Pipe and Fittings". Glands shall be made of ductile iron.

2-07.3 FLANGED FITTINGS

Flanged fittings shall conform to the requirements of AWWA Standard C110 or C153. Flanges shall be drilled to ANSI B16.1, 125 lb. standard bolt pattern. The 250 lb. flanges, when required, shall be drilled to ANSI B16.1, 250 lb. standard bolt pattern.

2-07.4 GASKETS

Gaskets for flanged fittings shall be 1/8-inch thick ring type Non-Asbestos, vulcanized styrene butadiene rubber (SBR), or Neoprene rubber gaskets. Non-Asbestos type gaskets shall be manufactured from a non-asbestos material that meets the pressure ratings, drilling, and dimensional requirements of AWWA C111-12. The synthetic fiber content shall be aramid, bound by Nitrile (Buna-N) Rubber (NBR) and have a non-stick coating. Color shall be Green. In lieu of rubber gaskets, the 1/16-inch polytetrafluoroethylene (PTFE) GORE-TEX GR sheet gasketing material, applied full-faced, is an approved equal.

2-07.5 BOLTS AND NUTS FOR MECHANICAL JOINTS AND FLANGES

Tee-head bolts and hexagonal nuts for all mechanical joints shall be high strength, low alloy steel, meeting the current provisions of American National Standard ANSI/AWWA C111/A21.11, "Rubber-Gasket Joints for Ductile Iron Pressure Pipe and Fittings", and must be Cor-Ten as manufactured by NSS Industries, or approved equal.

Hexagonal bolts, nuts and washers for flanged fittings shall be zinc plated, high strength, low-carbon steel conforming to the chemical and mechanical requirements of ASTM A307, Standard Specification for Carbon Steel Bolts and Studs, 60,000 psi Tensile Strength, Grade A.

Stainless Steel 304 nuts and bolts are required for above ground installations, for steel pipe installations, for stainless steel tapping sleeves and for all

construction. For all stainless steel nuts and bolts, the Contractor shall strictly follow the torque limitations and shall use N5000.

Loctite® anti-seize/ rust preventer lubricant manufactured by the Henkel Company or approved equal.

All buried nuts and bolts shall be coated after assembly as per Section 2-00.01.

2-08 SLEEVES AND CLAMPS

2-08.1 TAPPING SLEEVES

Tapping sleeves shall have a stainless steel body with removable bolts. The outlet, body, flange, bolts and nuts shall be 18-8 type 304 stainless steel. All welds shall be fully passivated to restore stainless characteristics. Flange shall conform to AWWA Standard C207, "Steel Pipe Flanges for Waterworks Service-Sizes 4 Inch through 144 Inch", Class D ANSI 150 lb. with drilling recessed to accept standard tapping valves per MSS-SP 60. Bolt holes shall straddle pipe centerline. Shell gasket shall seal the full circumference of the pipe.

Tapping sleeves shall not be allowed where the connection size is equal to or greater than the main size. Tapping sleeves shall be of the mechanical joint type or the full circle stainless steel type. All tapping sleeves specified in this Section must withstand a 150 psi minimum working pressure and shall provide a positive seal around the pipe at each end of the sleeve. Tapping sleeves that seal only around the opening in the pipe may not be used. For working pressures above 150 psi, special approval must be obtained from the Utility. Size on size tapping is not permitted

APPROVED STAINLESS STEEL TAPPING SLEEVE MANUFACTURES

Ford Meter Box Company, Inc.	FTSS
JCM	Model 432
Mueller	Model H304SS
Power Seal	Model 3490
Romac Industries, Inc.	SST III

2-08.2 SPECIAL APPLICATIONS

Tapping sleeves for special applications, such as Belgian cast iron pipe, shall be of the full circle split body, stainless steel type as noted above. In special cases, fabricated steel tapping sleeves can be used with approval from the Utility.

2-08.3 CONCRETE CYLINDER PIPE

At the sole discretion of the Utility, tapping sleeves for concrete cylinder pipe may be required to be of the weld-on type, provided that pipe wall thickness is greater than 13 gauge and that welding is performed by a State certified pipe welder. For concrete cylinder pipe with a steel cylinder wall thickness of 13 gauge or thinner, the Utility may require a full circle, split body, fabricated steel type tapping sleeve, conforming to the provisions of these specifications.

APPROVED TAPPING SLEEVE FOR CONCRETE CYLINDER PIPE
(Full circle, wall thickness less than 13 gauge)

JCM	Model 415
Smith Blair.	Model 625

APPROVED TAPPING SLEEVE FOR CONCRETE CYLINDER PIPE
(Three piece weld on type, wall thickness greater than 13 gauge)

Koppl	Model CN-120 (full wrapper plate)
JCM	416 Type 2 (full wrap)
Smith Blair	627 Type II

2-08.4 REPAIR CLAMPS

Repair clamps shall be full circle (one-section) band and shall conform to AWWA C230, Stainless Steel Full-Encirclement Repair and Service Connection Clamps for 2 inch through 12-inch pipe. Repair clamps shall have a minimum 12” length and greater than or equal to pipe diameter. The band shall be 18-8 type 304 stainless steel. Bolts, washers and nuts shall be high strength, low alloy per ASTM A242 and AWWA C111. Clamp shall have a lap type EPDM gasket with molded tapered ends to provide equalized sealing at the lap joint on any pipe within the clamps’ range.

APPROVED FULL CIRCLE REPAIR CLAMPS
(Larger diameter water main repair clamps require City Engineer’s approval)

Mueller	540, 550
Romac	SS1, SS2, SS3
Smith Blair	256, 257, 261, 262, 263
JCM	161

2-09 MAIN LINE COUPLINGS

2-09.1 GENERAL

Sleeve-type couplings shall provide a flexible, watertight connection between two plain ends of pipe as shown on the construction plans or as directed by Engineer. For PVC, ductile iron, and gray iron pipe, all couplings shall be ductile iron solid sleeve type conforming to AWWA C110, with mechanical joint ends and long body no less than 12 inches. For steel, all couplings shall be standard steel couplings, with body no less than seven inches long. Bolts for exposed steel couplings shall be hot-dip galvanized. Bolts for buried steel couplings shall be Type 316 stainless steel. The Contractor shall strictly follow the torque limitations and shall use N-5000 Loctite® anti-seize/rust preventer lubricant manufactured by the Henkel Company, or approved equal. All sleeve type steel couplings shall be fusion bonded epoxy lined and coated with Scotchkote 6233, as manufactured by 3M/Corrosion Protection Products, or approved equal. Buried metal surfaces shall receive additional protective coating and wrapping after they are assembled as per Section 2-00.01.

2-09.2 SLEEVE TYPE COUPLINGS

Sleeve type couplings shall provide a flexible water tight connection between two plain ends as described when shown on the construction drawings. For PVC, ductile iron, and gray iron pipe, all couplings shall be ductile iron solid sleeve type couplings conforming to AWWA C110, with mechanical joint ends and body not less than 12 inches long, and shall be lined and coated as described per Section 2-13.

For steel, all couplings shall be standard steel couplings, with body not less than 7 inches long. Bolts for exposed steel couplings shall be hot-dip galvanized. Bolts for buried steel couplings shall be of type 316 stainless steel. The Contractor shall strictly follow the torque limitations and shall use N-5000 Loctite® anti-seize/rust preventer lubricant manufactured by the Henkel Company, or approved equal. All sleeve type steel couplings shall be fusion bonded epoxy lined and coated with Scotchkote 6233, as manufactured by 3M/Corrosion Protection Products, or approved equal.

Buried metal surfaces shall receive additional protective coating and wrapping after they are assembled as per Section 2-00.01.

APPROVED SLEEVE-TYPE COUPLINGS FOR DIP, CIP, AND PVC

Clow	MJ Solid Long Sleeve
Romac Industries, Inc.	RFCA or PVS-RFCA
Tyler Corporation	5-144L Long Solid Sleeves

APPROVED FLEXIBLE COUPLINGS FOR STEEL PIPE

Romac Industries, Inc.	Macro HP
Smith Blair, Inc.	411 Steel Couplings
Smith Blair, Inc.	Quantum Coupling Wide-Range

APPROVED FLEXIBLE COUPLINGS TO CAST IRON PIPE

Romac Industries, Inc.	Macro HP
Smith Blair, Inc.	OMNI 441 Ductile Iron Couplings
Smith Blair, Inc.	Quantum Coupling Wide-Range

2-09.3 DISMANTLING JOINTS

Dismantling joints shall be a self-contained flanged restrained joint fitting, including both flanged components and sufficient harness bars to withstand the imposed thrust. The dismantling joint shall be designed to provide no less than 5 inches of longitudinal adjustment and shall be installed with 4 inches of inward adjustment and 1 inch of expansion. The pressure rating will be determined by the flange configuration and all commonly used flanges shall be available. As standard, flanges conforming to AWWA C207 class D shall be used.

The dismantling joint shall be furnished as a complete assembly consisting of spigot piece, flange adapter, tie bars and gasket.

The spigot piece and the flange adapter shall be steel per AISI C1010-C1015. All exterior fasteners including tie bars shall be 304 or 316 stainless steel. Stainless steel fasteners and tie bars shall not be painted. Gasket material shall be EPDM or Buna-S. The dismantling joint shall be coated inside and out with a fusion bonded Epoxy coating applied to a thickness of 5 -10 mils. The epoxy shall comply with the requirements of NSF 61 and AWWA C550.

The dismantling joint shall comply with AWWA C219 where applicable, and the manufacturer shall operate an accredited Quality Management System to ISO 9001. The design pressure rating shall be equal to or greater than the mating flanges. The gasket seal and compression stud and nut arrangement shall be separate and independent of the tie bar restraint system. Seals between companion flanges and dismantling joint flanges shall be made by full faced or drop in ring-style gaskets. Tie bar diameter shall be equal to the corresponding bolt diameter of the mating flange and shall not extend outside the diameter of the flange diameter.

APPROVED DISMANTLING JOINT MANUFACTURERS

Dresser Industries	Style 131
Romac Industries, Inc.	Style DJ400
Smith Blair	900 Series

2-10 SERVICE LATERAL

2-10.1 GENERAL

All valves and fittings for use in the buried service line from the main to the meter setting appurtenance shall conform to the requirement of AWWA standard C800 "Underground Service Line Valves and Fitting" and meet the California Health and Safety Code Section 116875. The wetted surfaces of pipes, pipe fittings, and valves shall not contain more than 0.25% lead by average weight. All corporation stops and angle meter valves used for copper installations shall have compression connection of copper tubing. No soldering of any kind is allowed on service connection.

APPROVED MANUFACTURERS

Jones
Mueller
Ford

2-10.2 FITTINGS

2-10.2.1 CORPORATION STOPS

Corporation stops for 2-inch diameter valves and for diameter sizes less than 2-inch shall have AWWA tapered inlet threads (CC) as specified by AWWA Standard C800 "Underground Service Line Valves and Fittings". Outlet shall be compression connection for copper tube.

2-10.2.2 ANGLE METER VALVES

All angle meter valves shall be full port "ball" type, have a locking wing on the key operator, and with 360 rotation of tee head. All valves for 5/8 x 3/4 inch and 1-inch meters shall have a compression connection inlet and a meter swivel nut outlet. All 2-inch valves shall have a compression connection inlet for 2-inch copper tubing and a meter flange outlet slotted to accommodate 1 1/2 inch and 2-inch meters. Slot should not extend to the outside edge-open slot will not be accepted.

2-10.2.3 BOLTS AND NUTS FOR METER FLANGE CONNECTIONS

All bolts, nuts and washers for flanged fittings shall be an approved similar metal as the flanges, to resist corrosion and for easy removal after lengthy service. SS304 or SS316 with anti-seize lubricant.

All service saddles shall be bronze conforming to ASTM B-62, double strap and tapped. Service saddle and tap for 2-inch diameter and for diameter sizes less than 2-inch shall have AWWA tapered threads as specified by AWWA Standard C800 "Underground Service Line Valves and Fittings".

2-10.3 COPPER TUBING

2-10.3.1 GENERAL

This specification shall cover the requirements for 1-inch and 2-inch seamless, annealed, Type "K", copper water tube. Copper tubing shall meet the requirements of ASTM B-88, "Specifications for Seamless Copper Water Tube". The 2-inch copper water tube shall be of rigid.

2-10.3.2 DIMENSIONS

Copper tubing shall be furnished in coils or straight lengths, as follows:

SIZE	FORM	LENGTH
1"	Coils	60' to 100'
2"	Straight Lengths (rigid)	20'

Coils shall be wound in a single layer flat with a minimum 24-inch inside diameter.

2-10.3.3 TEMPER

Copper tubing shall be furnished in the annealed condition in accordance with the technical property requirements of ASTM B-88. Straight lengths shall be annealed after being drawn.

2-10.4 RED BRASS PIPE

Brass pipe shall conform to the requirements of the "Specifications for Seamless Red Brass Pipe, Standard Sizes" ASTM Specification B-43 and referenced in the appendix to AWWA Standard C800. Fittings shall be of

bronze conforming to the requirements of ASTM B-62, "Specifications for Composition Bronze or Ounce Metal Castings".

2-10.5 SERVICE TAPPING TO CONCRETE CYLINDER PIPES

Service tapping to concrete cylinder pipes shall only be made under special approval by the Utility. Unless specified otherwise, tapping shall be a minimum of 2-inch NPT with bushing, as needed.

APPROVED SERVICE SADDLES TO CONCRETE PIPE

Smith Blair 362

2-10.6 SERVICE TAPPING TO PVC PIPE

For dry tapping 1" and 2" services on PVC pipe, the hole shall be bored into the pipe with a hole saw that retains the coupon and allows the shavings to fall clear of the hole. The service saddle shall be centered over the hole, seated, and tightened, and then the corp installed using pipe thread sealant.

2-10.7 METER BOXES

Meter boxes shall be concrete having a compressive strength of 4000 psi. Meter boxes shall have a concrete cover and drop in reading lid. Body of the meter box shall be constructed with a "ring" at the top to prevent settlement.

Where required, meter boxes shall have traffic load rating covers. Meter boxes shall be manufactured by Armorcast, or approved equal, as indicated below.

APPROVED METER BOXES

<u>Meter Size</u>	<u>Meter Box Size</u>	<u>Box/Cover/Drop-In Lid</u>
5/8"x3/4" and 1"	13"Wx24"Lx12"D	Armorcast
1 1/2" and 2"	17"Wx30"Lx12"D	Armorcast

2-11 INSTALLATION SMALL METERS

2-11.1 POSITIVE DISPLACEMENT TYPE

2-11.1.1 GENERAL

Meters 2-inch or less in size are classified as small meters and shall conform to AWWA C700, Standard Specifications for "Cold Water

Meters — Displacement Type, Bronze Main Case". All meters shall consist of a bronze main case with serial numbers stamped on the main case. All meters shall be read in cubic feet.

The City uses Standard Meters. The meter uses a coding unique to the City that can only be requested by the City. Therefore all meter requests and orders are to be fulfilled through by the City through their distributor.

2-11.2 RESIDENTIAL FIRE SERVICE TYPE

2-11.2.1 GENERAL

Meters serving residential buildings designed to meet NFPA 13D Fire Sprinkler Systems in One and Two Family Dwellings and Manufactured Homes shall be in compliance with applicable sections of AWWA Standard C701, and shall hold a current UL Fire Service Approval. The meter type shall be reviewed and approved by the City Engineer and Building Official. Meters shall have a minimum strainer open area of four times the inlet pipe diameter and shall be capable of providing full meter flows under a "locked" measuring element condition. All meters shall be lead free compliant and stamped with serial numbers on the main case. All meters shall be read in cubic feet.

2-12 SHOP DRAWING AND MATERIAL SUBMITTALS

The Contractor shall furnish to the Utility such working drawings, data on materials, certifications of materials, and equipment and samples as are required for the proper control of the work, including, but not limited to, those working drawings, data and samples specifically required in the SSPWC and on the Drawings. All working drawings, data and samples shall be subject to review by the Utility for conformity with the drawings and specifications. The shop drawings shall be submitted at least ten (10) working days before such drawings will be required for commencing the work.

2-13 PAINTING - ABOVE GROUND INSTALLATIONS

After ALL Testing and Disinfection has passed, but prior to Final Acceptance by the Utility, all above ground installations shall be painted in accordance with the following unless otherwise directed:

Remove ALL dirt, oil, grease, rust, bituminous coating, and other contaminants from surfaces to be painted by sand-blasting, pickling, or wire brushing as required. Clean all surfaces with a SCAQMD compliant, biodegradable surface cleaner as may be necessary. Allow surfaces to dry completely then apply primer to all surfaces to be painted. Allow primer to dry, then apply intermediate coat to all surfaces; allow intermediate coat to dry, then apply finish coat. The underlined generic terms in the above paragraph shall be considered together as a painting system and shall be supplied by a single manufacturer.

Exterior surfaces of hydrants and other above ground appurtenances shall be painted with Vista's Blue Wave #Q13-28T, or approved equal.

2-14 ACCESS TO MANUFACTURING AND TEST FACILITIES

The Utility shall at all times have access to the manufacturing and test facilities, and the right to inspect the work, and materials. The manufacturer shall furnish the Utility with reasonable facility access for obtaining such information as necessary to assess the progress of the work, and the character and quality of materials used. When requested by the Utility, the manufacturer shall submit a certificate of compliance that the product meets the requirements of these specifications.

SECTION 3 - CONSTRUCTION METHODS AND CONTROL

3-01 INSPECTION

The construction of any water system improvement intended for dedication to the City and used by the Utility for public water service shall be subject to inspection by the Utility. Such inspection will assure the Utility that all phases of the work are in compliance with these standards. The Utility Inspector will be the representative of the WHITTIER UTILITY AUTHORITY and shall coordinate the various responsibilities of the Utility throughout the work.

The Utility shall have access to the work and shall be furnished with every reasonable facility for ascertaining full knowledge of the progress, material, and workmanship used to complete the work. The Utility shall be given 48-hours advance notice of major phases of construction for purposes of inspection unless noted otherwise on the construction drawings. All material shall be inspected prior to placement and all workmanship shall be visually inspected prior to backfilling. Reasonable aid shall be given to ascertain the exact location of all work.

The inspection of the work shall not relieve the Contractor of any obligation to complete the work as prescribed by these specifications. Defective work shall be made good, and unsuitable materials may be rejected notwithstanding the fact that such defective work and unsuitable materials have been previously accepted by the Utility.

The Utility shall have the authority to suspend the work wholly, or in part, for such time as it may deem necessary due to the failure of the Contractor to perform any provisions of the plans and/or specifications. The work can only continue when the defective material or method is recognized as corrected by the Utility.

3-2 PRE-CONSTRUCTION DETAILS

3-2.01 PERMITS AND LICENSES

The Contractor shall have a Class "A" General Engineering or "C-34" Pipeline Contractor's License valid in the State of California and shall meet all the applicable requirements of the Whittier Municipal Code. The Contractor shall have a current, valid City of Whittier business license. The Contractor shall obtain all necessary permits, licenses, or agreements required by any legally constituted agency. An excavation permit from the City Engineer shall be required for excavation in the public right-of-way within the City of Whittier. A copy of all licenses and permits required for the project shall be provided to the City prior to starting work. The Contractor shall observe all safety procedures as required by CAL-OSHA. All provisions of these permits, licenses, or agreements shall be binding upon the

Contractor as though stated herein. The Utility will not be responsible for actions involving the agencies controlling such permits, licenses, or agreements.

3-2.02 TRAFFIC CONTROL

The Contractor shall furnish all materials, labor and traffic controls necessary to safeguard the work and the public safety.

Traffic and pedestrian control shall comply with the applicable provisions as contained in the latest edition of the State of California Manual of Traffic Controls. All traffic control plans shall be reviewed and approved by the City.

3-2.03 SURVEYING

The Contractor shall provide equipment, method, and labor to locate accurately all proposed water facilities unless otherwise specified by the Utility. The Contractor shall further guarantee the accurate location of all water facilities by constructing curb and gutter prior to the beginning of any water improvements. If, in the opinion of the Utility, this sequence of construction cannot be followed, the Contractor will sign a "Waiver of Curb and Gutter Requirements" and assume all responsibility and costs for correcting any resulting errors or omissions.

3-2.04 POLLUTION PREVENTION & BEST MANAGEMENT PRACTICES

Storm water and non-storm water discharges resulting from municipal construction activities are currently governed by the Los Angeles Regional Water Quality Board NPDES Permit No. CAS004001. The permit applies to municipal activities within the County of Los Angeles. The Contractor shall install all necessary Best Management Practices (BMP's) to comply with proper pollution control practices at construction sites. For more information on BMP's and compliance with Construction General Permit (CGP) refer to California Storm Water Quality Association website-<http://www.cabmphandbooks.com>.

3-3 REMOVALS AND TRENCH EXCAVATION

3-3.01 REMOVAL OF PAVEMENT

The City has a street cut moratorium list of streets recently paved. The prohibition includes asphalt overlays, pavement reconstruction, and new pavement construction. Contractor is required to verify if a street is on the moratorium prior to construction within the City limits.

In the case of new developments on adjacent properties, work mandated by the City, State, or Federal agency, and emergency repairs to subsurface facilities or underground service connections. The moratorium requires additional pavement removal and replacement.

Asphalt concrete paving and concrete paving shall be saw cut prior to removal. All edges shall be as straight as possible. Contractor shall dispose of the pavement off the work site to a permitted facility.

3-3.02 REMOVAL OF UTILITIES

Utilities shall be removed only as stated on the construction plans. Structures or piping not shown on the construction plan shall be brought to the attention of the Utility. Disposition of these structures shall be determined by the Utility prior to proceeding with the work.

The Contractor shall notify and coordinate with representatives of any utility which must be removed and/or relocated.

All abandoned valves should be removed from the system, except where authorized by the Utility.

3-3.03 TRENCH EXCAVATION

Trench excavation shall include any excavation in which the depth is greater than the width at the bottom of the excavation. Such excavations as required for vaults, thrust blocks, boring pits and service laterals shall be considered as trench excavations. All earthen material and water that will interfere with the placement of the pipe shall be removed. Contractor shall use sufficient means to protect any existing utilities from damage during trench excavation. Contractor shall also use Best Management Practices (BMP's) to prevent silt, mud, or other pollutants from entering storm drains or catch basins as a result of trenching or excavating activities.

The maximum length of open trench shall be 500 feet or the length of pipe installed in one day, whichever is less. An open trench of up to 1,000 feet is permissible only in areas not subject to public traffic. The width of the trench at the bottom of the excavation shall not exceed 10 inches on either side of the pipe. Bell and coupling holes shall be used as required to complete a satisfactory pipe joint.

Water main installation will not be permitted until subgrade is established and the storm drain and sewer installation have been completed. Pipe shall be placed to the grade and depth specified on the construction drawings. When not specified, pipe shall be placed as follows:

- a. 42-inch standard cover to finish surface of primary and secondary streets, (64 feet right-of-way and greater).
- b. 42-inch standard cover to finished surface of collector and interior streets (less than 64 feet right-of-way).
- c. 12-inch standard vertical clearance from any crossing utility or structure.
- d. 5-foot standard horizontal clearance from any utility or structure, except sanitary sewers, which require a minimum horizontal separation of 10-feet (outside wall-to-outside wall).

In all cases pipe shall be installed so that there is a minimum of 24" cover between top of pipe and bottom of pavement structural section. The minimum cover and clearance herein stated applies to construction where there are existing underground facilities. These minimums are not intended as "design minimums" where all new underground facilities or two or more conflicting facilities are installed at the same relative time. The design shall attempt to maximize clearance between conflicting facilities and provide standard cover as the minimum.

The trench bottom shall be graded to provide a smooth, firm, and stable foundation which is free of rocks and other obstructions. All soft, spongy, and unstable material shall be over excavated to a depth of two feet, replaced with backfill material per Section 3-08 of these standards, and compacted to provide a firm and stable foundation. All rocks or cobbles two inches or greater in any dimension shall be removed to a depth of six inches below pipe grade and replaced with compacted backfill material.

3-4 CONNECTION TO EXISTING FACILITIES

3-4.01 GENERAL

The Contractor shall make connection to the existing public facilities as shown on the construction drawings. All connections must be made under inspection of the Utility. The Utility Inspector will consider the means of chlorinating those sections of main, fittings, or valves in contact with the public system. When such connection provides a direct closure between the existing public system and that under construction, such valves shall become the property of the Utility and shall be **operated only by the Utility.**

The connecting joints between existing pipe and existing valves are typically unknown. The Contractor shall expose all joints to confirm the existing piping is restrained prior to tie-in with or abandonment of existing pipe and valves. The Contractor shall exercise due caution during tie-ins and abandonment work, including any temporary bracing until the Contractor has installed permanent restraints to all joints.

Permanent restraints shall follow the Standard Drawing W-636 or as called for by the Utility after a field determination can be made. The Utility shall verify and approve that the thrust restraint device proposed by the Contractor will be acceptable for the site conditions.

3-4.02 PRESSURE TAPPING

Cast iron, ductile iron, PVC or asbestos cement pipe can be tapped under pressure by the Contractor. The exterior surface of the pipe shall be cleaned to provide a smooth surface for the tapping sleeve. The tapping sleeve shall be secured to the pipe to prevent movement during the tapping process. Prior to tapping operation, the tapping sleeve shall be hydrostatically tested for any leaks. It shall be tested to withstand 1.5 times the local static pressure, or 150 psi, whichever is greater. Concrete cylinder pipes shall be tapped under pressure by the Koppl Company, Montebello, International Flow Technologies, Inc., Anaheim, California, or approved Contractor. Tapping nozzles shall be bolted or welded on as determined by the Utility based on steel cylinder thickness.

3-4.03 SHUTDOWN OF MAIN

All work necessary to shut down an existing public water main for the benefit of a Contractor shall be by Water Services personnel and shall require prior

approval by the Water Division. Under no circumstances shall the Contractor operate valves, hydrants, and other appurtenant equipment on the existing public system without the direct supervision of the Utility Inspector. It shall be the Contractor's responsibility to coordinate the necessary shutdown schedules through the Utility Inspector assigned to the project. Scheduled shutdowns shall require sufficient time to allow operations personnel to review, approve, and develop an appropriate Operation Program. The Contractor shall be responsible for maintaining all schedules current and coordinating all deviations which may occur from time to time with the Utility Inspector.

The City will make a concerted effort to isolate the system as planned with the Contractor. However, the Contractor shall be prepared to employ pumping equipment if a water tight seal cannot be achieved. City will not be responsible for any delays due to system shutdown and isolation.

All emergency situations shall be reported immediately to the Utility (Afterhours emergency number 562-567-9200). When extensive main shutdown is required, the Utility will determine what temporary service connections may be required. The Contractor shall furnish all necessary hose, piping, valves, water trucks and associated labor required to provide such temporary service. All piping, hoses and associated equipment used in temporary service connections shall be flushed and disinfected in accordance with Section 3-10, TESTING, DISINFECTION, AND FLUSHING.

Scheduling Sequence and Hours of Work on Water Systems. The Contractor's work shall be performed in such a manner that all disruption of water service and main shutdowns will be kept at an absolute minimum (six hours maximum). Water main bypass and allowable water main shutdowns shall conform to the time and periods outlined herein. The exact time and day of each shutdown shall be closely coordinated with the affected establishments and residences to reduce interruption of their respective activities.

The Contractor shall make all efforts in advance of construction to assure that disruption of water service will not occur during critical consumer daily water demands. The Contractor shall coordinate all consumer service shutdowns with the affected consumers and the WUA's inspector.

The City of Whittier does not guarantee a complete shutdown. The City considers approximately 150 gallons per minute to be a workable shutdown. This equates to approximately "half a pipe" of water flowing from a 6 inch plane end pipe. If a complete shutdown cannot be achieved, the Contractor shall be responsible for dewatering the trench for safe working condition. Contractor shall also be

responsible for installing all necessary erosion and sediment control devices.

The Contractor shall notify the Los Angeles County Fire Department for fire watch stand-by 48 hours prior to water system shutdowns.

Notification of Proposed Water Service Interruptions and Main Shutdown. Water mains, fire lines, and water services shall be maintained in active uninterrupted service during the course of the construction contract. The Contractor shall be responsible for notifying all affected parties of any unforeseen schedule alterations that may occur.

The Contractor is responsible for providing continued water service to all properties during construction, unless otherwise directed by the Engineer. This may require the Contractor to schedule shutdowns during non-working hours such as weekends, evenings, or holidays, when these locations are not using water. The Contractor is responsible to pay for inspection on these special non-working hours.

The Contractor, as an option during construction, may install a temporary hot tap or installation of a new unused hose from a nearby fire hydrant. The Contractor is responsible for all labor, material and equipment required for the temporary water service. The Engineer must approve all temporary services and materials used. Contractor shall request placement of a temporary construction meter from the City of Whittier Water Division.

In cases of necessary shutdowns of any portion of the existing utility system for the purposes of connecting to and testing of the newly-installed water piping, temporary shutdown, etc., the Contractor shall provide a schedule for such shutdown as developed themselves and approved by the City Engineer.

The schedule should include such information as the locations, dates, time, anticipated duration of each shutdown, and all affected residential, commercial, and industrial consumers. Prior to temporary shutting down of any water main for the installation of new piping, the Contractor shall perform (at each work location) all excavations, verification of existing water main facilities, and fabrication of the new piping to ensure that all connection materials are compatible with existing mains. Tie-ins shall conform to the City of Whittier Water Utility Standard Specifications.

The Contractor shall give written notification to all customers of a shutdown at least three (3) working days in advance, stating time of shutdown and estimated

duration. This notice shall not be distributed until the WUA Inspector receives and approves the following three (3) items:

1. Hard copy of the document stating the relevant section of pipe has passed the bacteriological test.
2. The notice letter for Engineer's review and approval.
3. A written request for water system shutdown.

WUA shall have five (5) working days to review and respond to the items above.

NOTE: The City's Water Division is fully staffed Monday through Thursday. Friday shutdown must be approved by the water division. When possible, water system shutdowns shall be scheduled when the Water Division is fully staffed.

Upon approval of temporary shutdown, the City's Water Division Crews will operate all valves necessary to isolate each pipeline to be joined or relocated from the rest of the water system. **In no event shall the Contractor be allowed to shut down active water mains, or operate City owned valves. The Contractor shall coordinate any and all valve operations with the City of Whittier Water Division.**

3-5 LAYING OF DUCTILE IRON PIPE WATER MAIN

3-5.01 GENERAL

Installations of pipe and fittings shall be in accordance with AWWA Standard C600, "Installation of Ductile-Iron Water Mains and Their Appurtenances" and the pipe manufacturer's installation manual. The DIPRA Publication "Guide for the Installation of Ductile Iron Water Mains" shall be used for details of pipe installation practice except as follows and where noted otherwise on plans. Maximum deflection per joint for 8-inch and 12-inch pipe is 3 degrees; minimum laying radius for 18 feet pipe lengths is 345 feet. Maximum deflection per joint for 16-inch pipe is 2 degrees; minimum laying radius for 18 feet pipe lengths is 520 feet.

Water mains shall be installed to provide a 10-foot minimum horizontal separation between the outside wall of the water main and the outside wall of any sanitary sewer. In addition, installation shall comply with Standard Drawing W-640.

Every precaution shall be taken to prevent foreign material from entering the pipe while it is being placed in the trench. If the pipe-laying crew cannot put the pipe into the trench and in place without getting soil into it, the Utility may

require that before lowering the pipe into the trench, a temporary plug be placed over each end and left there until the connection is to be made to the adjacent pipe. During laying operations, no debris, tools, clothing or other materials shall be left in the pipe.

At times when pipe laying is not in progress, the open ends of pipe shall be closed by watertight plug or other means approved by the Utility. This provision shall apply during the lunch-hour breaks as well as overnight. If water is in the trench, the seal shall remain in place until the trench is pumped completely dry.

The cutting of pipe for inserting tees, fittings or closure pieces shall be done in a neat workmanlike manner without damage to the pipe or cement lining and so as to leave a smooth end at right angles to the axis of the pipe. No pipe shall be laid in water or when, in the opinion of the Utility trench conditions are unsuitable. Field welding of Ductile Iron Pipe for repair or for joining is prohibited.

3-5.02 THRUST RESTRAINT

The Contractor shall be responsible for anchoring the pipe and fittings against movement due to water pressure. The materials specified in Section 2-03 will be used for restraining any movement of underground piping systems. See detail W-636 for Restrained Joints.

Concrete thrust blocks require prior approval from the City Engineer. Concrete thrust blocks shall be poured in place against an undisturbed earth bearing surface. Concrete shall be placed so as not to interfere with the fitting joint. Concrete shall be per Standard Drawing W-635. Thrust block locations and dimensions shall be per Standard Drawings W-635.

3-5.03 STANDARD ASSEMBLIES

Fire hydrants shall be constructed per Standard Drawing W-617.

Fire Hydrants shall be placed at a location shown on the construction drawing or as directed by the inspector. The determination will be based on specific locations which, in the opinion of the Utility, could result in potential hazard from the fire hydrant being hit and broken, such as closeness to overhead power lines or water damage to property. Where required by the construction drawing, guard posts shall be installed per Standard Drawing W-616.

Water valves shall be installed at locations shown on the construction drawing,

or as directed by the Utility. Valves shall be set plumb, and shall be stabilized and supported separately from the pipeline. Information regarding size, type, make, and number of turns to close shall be supplied to the Utility by the Contractor in accordance with Section 2-12. All valves shall be covered with a valve box assembly. Valve boxes shall be plumb, centered over the valve nut, and supported separately from the valve body per Standard Drawings W-620 and W-621. Valve boxes shall be lowered to below paving grade level prior to street paving, and after final grade has been established. In any event, Contractor shall ensure that all valve boxes will provide access to the operation of the valve by the Utility. Valve boxes shall be flagged or barricaded during construction to divert traffic around their location.

3-5.04 PROTECTION AND CLEANING OF PIPE AND FITTINGS

The Contractor shall take extreme care to insure cleanliness and protection of the inside coatings of all piping and fittings. The interior surfaces of all pipe, fittings and other appurtenances shall be kept free of dirt or foreign matter at all times. All lumps, blisters, excess lining and coating materials shall be removed from the flanged end or bell and spigot end of each pipe or fittings. The outside of the spigot and the inside of the bell shall be wire brushed and wiped clean, and free from oil and grease before the pipe is laid.

3-5.05 HANDLING PIPE AND OTHER MATERIALS

Proper implements, tools and facilities satisfactory to the Engineer shall be provided and used by the Contractor for the safe and convenient prosecution of the work. All pipes, fittings and valves shall be carefully lowered into the trench in such a manner as to prevent damage to water main materials and protective coatings and linings. Under no circumstances shall water main materials be dropped or dumped into the trench.

3-5.06 PROTECTION OF METAL SURFACES

All buried metal surfaces shall be protected and coated per Section 2-00.01 as applicable. Should the protective coating system to the buried or above ground metal surfaces be damaged or compromised in any way, the Contractor shall repair the damaged coating/ wrapping system to the satisfaction of the Utility.

3-6 LAYING OF PVC PIPE WATER MAIN

Installations of pipe, bends, and fittings shall be in accordance with Section 2-02 for ductile iron bends and fittings, and AWWA C605 "Underground Installation of

Polyvinyl Chloride (PVC) Pressure Pipe and Fittings for Water" and the pipe manufacturer's installation manual. PVC bends and fittings are not allowed. The Uni-Bell Handbook of PVC Pipe-Design and Construction shall be used for details of pipe installation practice except as follows and where noted otherwise on plans. Longitudinal bending of pipe sections is prohibited. Any directional change shall be accomplished through manufacturer approved deflection of push on joints.

The tracer wire and warning identification tape shall be installed per Section Drawing W-648. Tracer wire shall be Copperhead Industries Model #10CCS High Strength 600# Break Load with Locking SnakeBite Tracer Wire Connectors insulated copper, blue in color, or approved equal.

Warning tape shall be 6-inch wide, blue in color and marked "Caution Water Line Below".

Service saddles are required for all corporation stops 2-inch diameter and less.

Point load set screws in retainer glands and flanges are prohibited, whereas those devices with pads or full circle are acceptable.

Water mains shall be installed to provide a 10-foot minimum separation between the outside wall of the water main and the outside wall of any sanitary sewer. In addition, installation shall comply with Standard Drawing W-640.

Every precaution shall be taken to prevent foreign material from entering the pipe while it is being placed in the trench. If the pipe-laying crew cannot put the pipe into the trench and in place without getting soil into it, the Utility may require that before lowering the pipe into the trench, a temporary plug be placed over each end and left there until the connection is to be made to the adjacent pipe. During laying operations, no debris, tools, clothing or other materials shall be left in the pipe.

At times when pipe laying is not in progress, the open ends of pipe shall be closed by watertight plug or other means approved by the Utility. This provision shall apply during the lunch-hour breaks as well as overnight. If water is in the trench, the seal shall remain in place until the trench is pumped completely dry.

The cutting of pipe for inserting tees, fittings or closure pieces shall be done in a neat workman like manner without damage to the pipe and so as to leave a smooth end at right angles to the axis of the pipe. The beveled end of any PVC pipe shall be cut off before the pipe is inserted into a mechanical joint bend or fitting. No pipe shall be laid in water or when, in the opinion of the Utility, trench conditions are unsuitable.

3-7 SERVICE LATERALS

3-7.01 GENERAL

One-inch and two-inch diameter service laterals shall be installed per Standard Drawing W-601 and W-602, respectively. The service lateral shall consist of the double strap service saddle, polywrap per Section 3-11.03, insulated corporation stop, angle meter valve, meter, meter box and lid, and copper tubing. Service laterals shall be installed perpendicular to the centerline of the street.

Meters and meter boxes shall be supplied and installed by the Contractor at such time and place as directed by the Utility. Meter boxes located in areas subject to traffic loading, or located behind a rolled curb shall be installed with an approved traffic bearing lid.

Special consideration shall be given to backfill and compaction in the area adjacent to the copper tubing that is "snaked" in the trench. The area adjacent to the tubing shall be considered to extend not less than 4-inches below and 4-inches above the copper tubing and shall include the entire width of the trench. Bedding and backfill shall conform to Section 3-08 of these specifications. Backfill material shall be compacted under the service lateral so as to create a firm laying bed prior to placing and compacting any material over the top of the lateral. Compaction of backfill material by mechanical means directly over the exposed service tubing shall not be allowed.

All existing active and inactive services and laterals not intended for reuse shall be cut and capped at the main and abandoned under direction of the Utility.

Prior to any modification of service laterals 4-inches or larger and within 20-feet from the existing valve, the Contractor shall expose the valve on the service lateral to ensure the lateral including the valve is adequately restrained to the main pipeline. The exposed valve is to be witnessed by the Utility for verification of restraint. Inadequately restrained valve shall be properly restrained by the Contractor.

All water service connections may require the installation of a backflow device in accordance with Section 5 of these specifications.

3-7.02 IRRIGATION SERVICES

Services installed for the primary purpose of providing irrigation of landscapes or commercial crops, and which may have booster pumps downstream of the meter, shall conform to the following requirements:

1. A hydraulically actuated, slow open/close valve shall be provided immediately downstream of the pump or a surge tank, properly sized and

approved by the Utility.

2. A Reduced Pressure Principle type backflow preventer will be required immediately downstream of the flow meter.

3-8 PIPE BEDDING AND BACKFILLING OF TRENCH

The Contractor shall backfill the pipe trench as soon after placement of pipe as practical with due regard of the requirements in this Section. All fittings, valves, utility crossings, and assemblies shall be visually inspected by the Utility prior to backfilling. Pipe bedding shall be defined as that material supporting, surrounding and extending to a minimum of 12 inches above the top of pipe and shall consist of imported material having a sand equivalent (SE) of not less than 30 or other material approved by the Engineer. **No native material of any kind may be backfilled in trenches within the City of Whittier.** Bedding and backfill shall be placed in accordance with the the "Standard Specifications for Public Works Construction" and as supplemented herein. All backfill for pipe or conduit shall be densified to a relative compaction of 90% minimum by water densification, mechanical tampers or rollers or other mechanical means, as approved by the Engineer.

All buried valves and fittings are to be backfilled with imported material having a sand equivalent of not less than 30 or other material approved by the Engineer. The material shall be installed in such a manner that after compaction no earth or other backfill will be less than 6-inches from any part of the valve, fitting, flanges, bolts, or nuts. The material shall be compacted as specified for other backfill.

3-9 REPAVING AND FINISHING

The Contractor shall replace all removed or damaged pavement with a section equal to that removed, but not less than four inches of asphalt concrete (A.C.) over the subgrade.

If any work is allowed by the City Engineer on a street listed under the moratorium, pavement restoration work shall comply with requirements set forth for "Street Cut Restoration Standards", however, the City Engineer may determine that alternative restoration requirements are appropriate due to circumstances unique to the excavation site.

All pavement replacement, temporary or final, shall be hot-mix A.C. and as specified in the Plans or Specifications. The Contractor shall place pavement following final compaction of the backfill. The Contractor shall not wait for completion of the full length of pipeline installation to begin resurfacing; the pavement shall be repaired

and/or replaced, flush with existing road surface, within five working days of damage or removal of the pavement. Valve boxes shall be located after final paving and brought to finished grade. The Contractor shall remove the paving section down to the valve box, raise the valve box top section to finished surface, install the concrete collar per Standard Drawing W-621, and patch the paving section.

3-10 TESTING, DISINFECTION, AND FLUSHING

3-10.01 GENERAL

All required testing shall be performed and certified by a third party agency hired by the Contractor and approved by the City. All tests shall be made in the presence of the Utility Inspector, except that bacteriological tests shall be performed at laboratories certified by the California Department of Public Health. All constructed facilities shall be isolated from the existing public system while being tested.

3-10.02 HYDROSTATIC PRESSURE TESTING

After all thrust blocks have been placed for at least two days in the particular portion to be tested, a pressure test shall be conducted by a hydrostatic testing agency hired by the Contractor and approved by the City. Each section of main, up to but not exceeding 1,200 feet in length, and all fire hydrants and fittings connected thereto, shall be subjected to a hydrostatic pressure in accordance with AWWA Standard C600 and C605 and as modified herein, while all pipe, fittings and joints are inspected for leakage. Test pressure shall not exceed rated working pressure of the gate or butterfly valves. The section of pipe under test shall be allowed to stand at 40 psi minimum pressure for one (1) hour prior to the beginning of the test. The pressure shall then be increased to 1.5 times the local static pressure, or 150 psi, whichever is greater, to a maximum of 300 psi. Pressure shall be measured at, or corrected to, the lowest point in the portion of the line being tested. After the entire section under test has been inspected and no leaks have been found, or if found, have been repaired and re-subjected to the test pressure, the pressure shall be maintained for four (4) hours, during which time the amount of leakage shall be determined by measuring the quantity of water which must be added to maintain the test pressure. The following table lists the maximum allowable leakage per 1,000 feet of pipe, in gallons per hour, in conformance with AWWA Standard C600 and C605:

Maximum Allowable Leakage per 1,000 feet of Pipe, Gallons per Hour								
Static Pressure, PSI	Test Pressure	Nominal Pipe Diameter. in.						
		4	6	8	10	12	16	18
100 or less	150	0.33	0.50	0.66	0.83	0.99	1.32	1.49
110	165	0.35	0.52	0.69	0.87	1.04	1.39	1.56
120	180	0.36	0.54	0.73	0.91	1.09	1.45	1.63
130	195	0.38	0.57	0.75	0.94	1.13	1.51	1.70
140	210	0.39	0.59	0.78	0.98	1.17	1.57	1.76
150	225	0.41	0.61	0.81	1.01	1.22	1.62	1.82
160	240	0.42	0.63	0.84	1.05	1.26	1.67	1.88
170	255	0.43	0.65	0.86	1.08	1.29	1.73	1.94
180	270	0.44	0.67	0.89	1.11	1.33	1.78	2.00
190	285	0.46	0.68	0.91	1.14	1.37	1.83	2.05
200	300	0.47	0.70	0.94	1.17	1.40	1.87	2.11

If the pipeline under test contains sections of various diameters, the allowable leakage will be the sum of the computed leakage for each size.

3-10.03 DISINFECTION

3-10.03.1 GENERAL

All water mains, water services, attached appurtenances and connections shall be disinfected in accordance with AWWA Standard C651 "Disinfecting Water Mains", and as modified herein.

Contractor shall furnish all equipment, labor, materials, safety requirements, and water necessary for chlorinating and flushing the pipeline. Disinfection of new mains, including all chlorination, chlorine residual measurements, collection of samples, and certification shall be conducted by a third party testing agency approved by the City. Gauges and apparatus used for chlorine injection shall bear the current State certification. An independent State Certified laboratory or authorized agent shall collect the samples and a State Certified laboratory shall perform the bacteriological tests. All costs for disinfection, including laboratory fees, shall be paid by the Contractor.

At no time shall personnel other than the authorized third party testing agency be in charge of injecting chlorine into the water pipeline, the residual testing of the chlorine, or obtaining bacteriological samples.

Contractor shall insure that all pipe, fittings, and appurtenances are kept free from dirt and foreign matter at all times. During construction all open pipe ends and fittings shall be fitted with a water tight plug. At the end of the work day the open pipe in the trench shall be plugged in an equally suitable manner.

The Contractor shall swab the interior surfaces of the new valves, pipes and appurtenances as well as interior surfaces of existing main, both upstream and downstream of the new pipe section, with a minimum five percent concentration of hypochlorite disinfection solution before installation. During the chlorination or chlorinating process, all valves shall be operated, and the chlorine solution shall be drawn through all laterals and appurtenances. Disinfection of mains and appurtenances, hydrostatic testing, and chlorine retention may run concurrently for the required minimum 24-hour period only if prior approval is obtained from the Utility.

In the event of leakage or where repairs are necessary, added disinfection shall be made only by injecting chlorine into the line whereby adequate mixing is assured. If the test results are not satisfactory, the Contractor shall provide additional disinfection, as required. Such additional disinfection shall be at the Contractor's expense.

Disinfection of pipelines 4-inch or larger and in excess of 100-feet in length shall be accomplished by direct chlorine as specified herein, unless otherwise approved by the Engineer.

3-10.03.2

CALCIUM HYPOCHLORITE TABLETS

This method may be used under the direction of the Utility for pipe lengths 100 feet or less, and if the pipes and appurtenances have been maintained in a clean and dry condition during construction. The number of tablets used shall produce a residual of not less than 50 PPM and not to exceed 100 PPM of chlorine in all sections of the pipeline and appurtenances being disinfected when filled with water. During construction, five-gram calcium hypochlorite tablets shall be placed in each hydrant, hydrant branch, and other appurtenances.

All tablets shall be attached, using an approved adhesive, on the inside and at the top of the main, with approximately equal numbers of tablets at each end of a given pipe. Adhesive shall be a type that will not impart detrimental compounds to the water supply. The following table may be used as a guideline for the number of five-gram tablets needed to achieve 50 PPM chlorine residual for each 18-foot length pipe section, based on 3.25-g available chlorine per tablet, and with any portion of tablet rounded to next higher integer.

Pipe Diameter (In.)	Suggested # of 5g tablets
4	1
6	2
8	4
10	5
12	7

The fill rate when using tablets shall be regulated so that the velocity does not to exceed one (1) foot per second through the smallest main line being disinfected. If required by the Utility, water used to fill the new main during the application of chlorine shall be supplied through a temporary connection that shall include an appropriate cross-connection control device, consistent with the degree of hazard, for backflow protection of the active distribution system.

Chlorinated water shall be retained in the system for a minimum of 24 hours, and shall produce at the end of the retention period not less than 25 PPM of chlorine in all sections of the pipeline being disinfected.

3-10.03.3 FINAL FLUSHING

Following the chlorination period of 24 hours, the newly laid line shall be thoroughly flushed to remove any foreign material. A suitable connection shall be provided by the Contractor at the end of each new line at the invert large enough to achieve a flushing velocity in the line of at least 5 feet per second.

Water shall be flushed from the line at its extremities and at all outlets until the chlorine residual of the water system being flushed is equal to or less than the distribution system level.

3-10.03.4 BACTERIOLOGICAL TESTS

After the system has been flushed, the Contractor shall have tests

conducted for chlorine residual by a State Certified Laboratory approved by the City. Should the chlorine residual in any part of the disinfected system be higher than the distribution system level, the Contractor shall repeat the flushing procedure. If the chlorine residual after flushing is equivalent to or less than the distribution system level, the Contractor may proceed with the bacteriological sampling. Samples shall be taken at the direction of the Utility with at least one set of samples collected at 1,200-foot intervals along the new water main, plus one set at each dead-end main section, and at least one set from each branch (i.e., laterals 4-inch and larger). Two consecutive bacteriological samples are required for water quality evaluation. The first bacteriological sample shall be taken immediately after final flushing and the second sample shall be taken at least 24 hours later. If bacteriological test results fail to pass the requirements, the Contractor shall take corrective actions and daily bacteriological sampling shall be continued until two (2) consecutive negative samples are demonstrated. All samples shall be collected by certified laboratory personnel and tested for bacteriological quality in accordance with *Standard Methods for the Examination of Water and Wastewater*, and shall show the absence of coliform organisms.

The following tests are required to provide information for water quality evaluation:

1. Presence/Absence of Total Coliform by any of the three methods: Multiple Tube Fermentation, Membrane Filtration or Colilert/Colisure.
2. Heterotrophic Plate Count.
Report shall include:
 - a. Presence/Absence of Coliform Bacteria Count per 100 ml.
 - b. Heterotrophic Plate Count per ml.
 - c. Total and Free Chlorine Residual, taken at time of sample collection by certified laboratory personnel.

All coliform test results must be negative. The heterotrophic plate count shall be 500 or less per ml.

The results of these tests must be approved in writing by the Utility's Water Inspection Supervisor prior to activating any new water facilities. Should the test results from the State certified laboratory disclose that the water from the new line does not meet the above standards, the

disinfection process shall be repeated until it meets the required standards.

3-10.03.5 DISPOSAL OF TEST WATER

All water used in testing and disinfecting the portions of pipeline or water system component, including that used for retesting, shall be disposed of following such testing, retesting, and disinfecting by the Contractor at his sole expense. The disposal of water shall, in all cases, be carried out in compliance with the water quality objectives and discharge permit restrictions established by the California Regional Water Quality Control Board- Los Angeles, RWQCB (4), 320 W. Fourth Street, Suite 200, Los Angeles, CA 90013. Phone number: 213-576-6600.

For contracts administered by the City, the Contractor will be authorized to discharge test water to the storm drain under the National Pollution Discharge Elimination System (NPDES) permit issued to the City if all requirements and procedures per such permit are followed. For all other projects, including Developer projects, Contractor or Developer shall obtain an NPDES permit and comply with that permit.

Disposal of test water or chlorinated water used for disinfection will require the Contractor to apply a reducing agent (i.e. sodium thiosulfate, or ascorbic acid, etc.) to the test water in order to neutralize residual chlorine or chloramine to meet the discharge limitation. Additionally, the flow of water from the portions of pipeline shall be controlled to prevent erosion of surrounding soil, damage to vegetation, and altering of ecological conditions in the area and shall not contribute to silt, mud, debris, or other contaminants entering storm drains or surface waters.

The Contractor's attention is directed to that portion of the pipe with a low elevation. All water used in testing and disinfecting in that portion of the pipe shall be pumped out by the Contractor, at his expense, as specified in the paragraph hereinbefore. The Contractor shall furnish and operate all necessary pumps, pipelines, valves, hoses and all other appurtenances needed for pumping out water from the said low portion.

3-11 SPECIAL CONDITIONS

3-11.01 SHEETING AND SHORING

All trench excavation shall be adequately protected to provide a safe working condition, and protection to adjacent facilities and structures. The Contractor shall work in such a manner and install such protective devices, shoring, and bracing to comply with all rules, regulations, and orders of CAL-OSHA, Division of Industrial Safety. Prior to any trench excavation where the depth is more than five feet, the Contractor shall submit a detailed plan to the Utility showing the design of shoring, bracing, sloping, or other provisions to protect the workers from the hazard of caving ground during the excavation of such trench. If the plan varies from the shoring system standards, the plan shall be prepared by a Civil or Structural Engineer registered in the State of California. No excavation shall start until the Utility has accepted the plan and the Contractor has obtained a permit from CAL- OSHA, Division of Industrial Safety. A copy of the permit shall be submitted to the Utility and available at the job site at all times.

Sheeting and shoring shall not place any undue strain on existing utilities or structures, nor on completed sections of construction. Sheeting and shoring may be removed during backfilling, provided adequate protection is provided at all times. The Contractor shall be responsible for any damage to existing utilities or structures due to placement, removal, or failure of any sheeting and/or shoring system. The Contractor shall repair or have repaired any damage as soon as practical.

3-11.02 JACKING OF STEEL CASING

Steel casing shall be placed at the location, elevations, and limits shown on the construction drawings. Known existing utilities shall be shown on the construction drawings. Any utilities or structures encountered which will interfere with construction shall be brought to the attention of the Utility. Only new steel casing shall be used for jacking. Jacking shall be at a rate that will not over stress the casing, causing failure. Any damage to the casing during placement of the pipe shall be brought to the attention of the Utility. The jacking and receiving pit shall be sheeted and shored as required by CAL-OSHA and as provided in these specifications. The excavated area ahead of the casing shall not be larger than 0.1 foot greater than the outside diameter of the casing. Over excavation beyond the above described limits shall be sanded or pressure grouted as directed by the Utility. Sluicing or jetting ahead of the jacking casing shall not be permitted.

3-11.03 POLYETHYLENE PROTECTNE WRAPPING

Unless otherwise noted on the plans, polyethylene protective wrapping (Polywrap) for ductile iron pipe shall be furnished and installed on all buried water lines in accordance with the requirements of AWWA C105, Section 2-01.04 of these specifications, and as specified herein, except where water lines are within a steel casing pipe. Polywrap shall be installed so as to prevent any section of the pipe, fittings, valves, services, or appurtenances from contacting the soil. The 'polywrap' shall be taped to provide a snug fit along the pipe. Minimum tubing size shall allow for an overlap of 12 inches; i.e., flat tube width in inches= $(3.14 \times \text{outside diameter}) + 12$ inches. An additional 3 layer wrap of polyethylene shall be made at all tapping locations a minimum of 12 inches in width. Openings for service taps, blowoffs, or similar appurtenances shall be cut in the 'polywrap' during backfilling of the trench. Corporation stops and copper service lines shall be wrapped with polyethylene protective wrapping for a minimum clear distance of 3 feet from the water main.

Any punctures, tears or other damage shall be patched with polyethylene wrap and tape in accordance with the requirements of AWWA C105 and manufacturer's instructions. Rocks or other material that could damage the wrapping shall not be included in the backfill.

3-12 DEDICATION OF IMPROVEMENTS TO THE CITY

The Utility may serve temporary construction water through facilities installed by the Contractor. This use shall be permitted following written confirmations from the laboratory conducting bacteriological tests that all samples meet the requirements of the Utility and from the Utility. This use does not constitute acceptance of these facilities by the Utility.

The Utility will serve domestic water through facilities installed by the Contractor after the following items are received.

1. Written confirmation from the laboratory conducting bacteriological tests that all samples meet the requirements of the Utility.
2. Confirmation by the Utility that all water improvements have been constructed per applicable specifications and plans. Contractor shall be responsible to maintain accurate records of any changes made during the course of construction and shall submit such information to Utility per section 3-13 below.

3. Public Utility Easements dedicated to the City, as required to gain access to public water facilities located on private property.
4. Such agreements, fees, or other items as required by the Utility.

Prior to serving domestic water through the installed facilities, the Developer shall present all deeds or instruments of conveyance to the Utility and shall dedicate all water system improvements intended for public use to the City.

The Contractor shall warrant the quality of all material and workmanship for a period of one year from the date of acceptance of these facilities by the City. The Contractor shall make all repairs to facilities due to defect in material or construction method. Such repair shall not be the responsibility of the City. If the Utility should deem the repair of such defective work an emergency situation, the Contractor shall be held liable for all costs required to correct such defective work.

3-13 AS-BUILT DRAWINGS

The Contractor shall provide and maintain a complete, legible, and accurate As-Built record set of prints. Such prints shall be kept up to date as work progresses and shall be maintained at the job site during construction. Progress payments for City of Whittier projects will not be processed until the As-Built drawings are reviewed and approved by the Utility.

As-Built drawings shall be prepared and shall show all changes in the work constituting deviations from the original contract drawings. All conceptual or major design changes shall be approved by the Utility before implementing the change in the construction contract.

Upon completion of the work, all required information, dimensions and adjustments to the original contract drawings shall be submitted to the Utility to be transferred to the record drawings. Facilities and items to be located and verified on the record drawings shall include the following:

- a. Point of connections.
- b. Actual location of existing utility mains (water, sewer, gas, storm drain) and encased electrical conduit banks crossing the water main.
- c. Actual location of existing water, sewer and gas service laterals and communications conduit only when there is a conflict which requires a vertical and/or horizontal alignment change of the water main to be installed.
- d. Water mains: where deviations along installed water mains are more than

1 foot vertically and more than 1 foot horizontally, actual location (line and grade) shall be noted on the plans at intervals of 100 feet.

- e. Services: where service tie-in differs from the plan station by more than 2 feet or when meter box is not perpendicular from the main, corporation stops shall be stationed. For all service lines that have directional changes, such as in the case of cul-de-sacs, the actual installation shall be noted regardless of field changes, and shall be adequately referenced to the satisfaction of the Utility Inspector.
- f. Any material changes, including additions, deletions and substitutions.
- g. Other related facilities, as required by the Utility Inspector
- h. Contractor shall write on all sheets where the water improvements were built per plan that the construction was made "Per Plan".

The City's receipt and acceptance of As-Built drawings shall be a condition precedent to the release of the Contractor's retention/final payment. For projects constructed by Developers, the Utility will not give final acceptance until approved "as-built" plans have been received.

SECTION 4 - LARGE SERVICES AND FIRE LINES

4-01 GENERAL

All services larger than 2 inches in diameter installed for the purpose of obtaining water from the public system for domestic, irrigation, commercial or industrial consumption, or for fire protection shall be defined as large services. Large services installed for the purpose of providing fire protection only shall be further defined as Fire Lines.

Unless otherwise specified on the plans approved by the Utility, all materials, construction methods and controls shall conform to the applicable sections of the Water Utility Standard Specifications, which this section is a part thereof, including, but not limited to, Testing, Disinfection and Flushing.

4-02 DESIGN

The Developer or his/her Private Engineer or Contractor shall be responsible for preparation of the necessary design drawing(s) showing the proposed large service installation together with meter and appurtenances. The drawing(s) shall be prepared by a Registered Professional Civil Engineer licensed by the State of California, shall be submitted to the Utility for review and must be approved prior to beginning construction.

The drawing shall be prepared on a 24" x 36" Standard Plan sheet, if possible. Larger sizes shall be accepted only with prior approval from the City Engineer. The drawing shall show, but not be limited to, the following major items:

- Street Name and Cross Street Name
- Station from C/L of Street
- Intersection Size
- Type and Location of Street Main
- Public and Private Utilities
- Above and Below Ground Improvements
- Scale and North Arrow
- Width of Street, Location of Curb, Sidewalk and Property Line
- Location and Size of Proposed Assembly
- For Vault installations identity Type of Vault and Cover Required (Traffic Bearing or Pedestrian)
- Easement, if required
- Size of Service Lateral and Meter
- Reference to Standard Detail Drawings

4-03 FEES

The Utility will require the payment of Excavation Permit fees concurrently with filing the application and submission of the drawing for review. A fee for checking, preparing and recording of easement documents, when applicable, will also be required prior to drawing approval. Fees shall conform to the latest revision of the City of Whittier Fee Schedule. The applicant shall also complete a Utility Shutdown/Connection Request Form as a part of the Excavation Permit Application.

4-04 CONSTRUCTION AND INSPECTION

Upon approval by the Water Division of the Utility Shutdown/Connection Request Form and the Engineering Division of the Excavation Permit Application, the Developer may proceed to award the work to a Contractor of his/her choice.

The Contractor shall have a Class "A" General Engineering or Class "C-34" Pipeline Contractor's License valid in the State of California and shall meet all the applicable requirements of the Whittier Municipal Code. The Contractor shall be responsible for obtaining all construction permits and licenses as may be required by those agencies having jurisdiction over the work area.

The Contractor shall notify the Water Division of their intent to commence work at least five (5) working days prior to starting construction. Inspection shall be provided by the Water Division in accordance with Section 3-01 of these standards.

4-05 EASEMENTS

At the time of submittal of the application and drawings for first review, the Utility will advise the Developer whether an easement for water utilities is required. Should an easement be required, the Developer or his/her Private Engineer shall be responsible for preparing a drawing and legal description on the appropriate form. The easement drawing and description shall be prepared by a Professional Land Surveyor licensed by the State of California and shall be submitted along with a copy of the property owner's last deed of record to the Utility for checking and preparation of the Easement Deed. Execution of the Easement Deed, by the property owner, shall be required prior to drawing approval. A written waiver may be requested by the owner of the property on which the easement is required, in which case the execution of the easement deed, by the property owner, shall be required prior to final inspection and rendering of service by the Utility.

4-06 METERS

Separate water services for domestic water and fire protection shall be installed. No dual systems (fire and domestic service) or Fire Service Meters (FM) shall be allowed. In addition, if the Project's landscaping area is 2,500 square feet or larger, a separate irrigation meter shall be required. All meters service installations over 3 inches in size shall include a meter and shall be located outside of the public right of way on private property. Meters shall conform to size, type, and manufacturer as shown on the Standard Drawings. Meter sizes 2-inch or less shall be City Provided. All meters sizes 3-inch or larger shall be purchased by the owner and approved at the discretion of the City Engineer.

All Large Service installations, except Fire Lines, requiring a full size temporary bypass line shall be reviewed and approved by the City Engineer.

The Utility, at its sole discretion, may require the bypass line to have OS&Y valves with hand wheel operators and a permanent bypass spool. When OS&Y gate valves and spools are required by the Utility on the bypass line, the hand wheel operators shall be secured in the closed position by a lock and chain.

4-07 VAULT INSTALLATIONS

Underground Vault Installations shall be reviewed and approved by the City Engineer prior to installation. All Large Services installed underground shall be installed in a concrete vault with an aluminum cover, or as otherwise specified on the construction drawings. The dimensions of the vault, location of knock-out sections, and the cover details shall be in strict conformance with this section and the application Detail Drawings contained in Section 6 of these standards, or as otherwise specified on the construction drawings. The vault cover shall consist of one or two doors in one channel frame and shall open over the entire length and width of the vault. Door leaf shall be 1/4-inch aluminum diamond pattern plate to withstand a live load of 300 pounds per square foot. Channel frame shall be 1/4-inch aluminum. Door shall be equipped with heavy forged brass hinges, stainless steel pins, spring operators for easy operation, and an automatic hold open arm with release handle. A snap lock with removable handle shall be provided. Unless noted otherwise on the plans, hardware shall be mill finish with bituminous coating applied to the exterior of the frame. Stainless steel hardware may be required for installations in a highly corrosive environment. Manufacturer shall guarantee against defects in material and workmanship for a period of at least five years.

All vaults installed in areas subject to incidental vehicular traffic shall be steel

reinforced concrete with an aluminum cover designed to meet a minimum traffic bridge loading of H-20, as defined by the American Association of State Highway Officials. As to type, materials, and hardware, traffic covers shall conform to the requirements specified in the preceding paragraph. In certain situations, guard posts may be required to prevent vehicular traffic from passing over the vault.

When vaults are installed in areas subject to pedestrian traffic, the cover shall consist of non-skid materials as approved by the Engineer.

4-07.01 THRUST RESTRAINT- VAULT INSTALLATION

A positive means of thrust restraint shall be provided on the inlet line to a vault installation so that the pipe at the last joint, prior to entering the vault, is physically restrained from movement in the direction of the vault. See Standard Plan W-636.

4-08 PAINTING- ABOVE GROUND INSTALLATIONS

After ALL Testing and Disinfection have passed, but prior to Final Acceptance by the Utility, all above ground Large Service installations shall be painted in accordance with Section 2-13.

4-09 AESTHETICS- ABOVE GROUND INSTALLATIONS

Above ground Large Services shall be screened from public view by landscape plants and/ or walls as or other appropriate means as directed by Utility. Landscape plants shall incorporate varieties approved by the Parks, Recreation, and Community Services Department and shall be approved by the Utility. If a screen wall is proposed, landscaping including clinging vines shall be planted to soften the wall and discourage graffiti. If such wall is adjacent to a structure, the wall may also be required to be painted to match the exterior of the structure, if determined necessary by the Utility. The above ground service will be shielded from view on at least three sides, including the street side and the two adjacent sides. Regardless of which method of concealment is used, it shall neither obscure nor hinder access to the Fire Department's pumper connection.

Within the confines established by the Utility, the owner/developer shall locate all above ground large services in a manner which is aesthetically pleasing. Additional conditions may be required for specific projects in order to comply with local ordinances and zoning codes.

It shall be the owner's responsibility to irrigate and maintain planted landscape screening in a healthy state and to trim and prune them such that access to the device is not impaired. If owner fails to maintain landscape plants and paint in the desired state, City will cause such work to be performed and owner will be billed for the actual cost of performing the work plus ten percent for overhead and administration. Failure to pay for said work, when due, shall be cause for termination of service.

Please contact the Parks, Recreation, and Community Services Department at 562-567-9400 for a list of acceptable plants and vines.

SECTION 5- BACKFLOW PREVENTION

5-01 BACKFLOW PROTECTION

All water services connected to the public water system shall be required to include an approved backflow prevention device of the type designated by the Utility. The type of device approved shall be based on the existing or potential degree of hazard which exists, in the opinion of the Utility. All devices shall be approved by the Foundation for Cross-Connection Control and Hydraulic Research, University of Southern California, Los Angeles, CA 90089-2531. All domestic backflow prevention devices shall be lead-free per California Health and Safety Code.

The Developer or his/her Contractor shall be responsible for the installation, initial test and certification of all new or relocated backflow prevention devices. Thereafter, backflow prevention devices will be maintained and tested annually by the owner or water user.

The backflow prevention device installation shall be above ground, screened from view as approved by the Utility.

When an existing backflow prevention device that is located in public right-of-way needs to be replaced, the property owner shall be required to install the new device above ground on private property. Unless otherwise approved by the Utility, the entire section of piping between the water main and the new device shall be replaced with new pipe. In addition, design plans for the new device, and accompanying plan check and inspection fees shall be submitted to the Utility for review and approval, in accordance with these Standards.

Backflow prevention devices shall be located above ground, outside of the right-of-way and as close as practical to the meter. Location shall be subject to approval by the Utility and the City of Whittier's Community Development Department.

5-01.01 APPROVED MANUFACTURERS

Any backflow prevention devices approved by the Foundation for Cross-Connection Control and Hydraulic Research, University of Southern California, Los Angeles, CA 90089-2531, as shown on the latest edition of "List of Approved Backflow Prevention Assemblies".

5-02 FIRE LINE ASSEMBLY

All fire line assemblies shall require a detector meter and backflow protection as may be determined by the Utility. All fire lines shall be installed in conformance with Section 6 of these Standards. Vault installation of fire line assemblies is prohibited.

For assemblies that require a detector meter, the meter shall be 3/4 inch nominal size with bronze case and shall have a straight read magnetic drive register capable of detecting increments of consumptive use in one cubic foot increments.

SECTION 6- STANDARD DRAWINGS

WATER UTILITY STANDARD DRAWINGS

W-601	1" WATER SERVICE INSTALLATION
W-602	2" WATER SERVICE INSTALLATION
W-603	3" THROUGH 8" METER LATERAL INSTALLATION
W-604	ABOVE GROUND METER INSTALLATION 3" & LARGER
W-605	UNDER GROUND METER INSTALLATION 3" & LARGER
W-606	ABOVE GROUND METER- FIRE INSTALLATION
W-610	REDUCED PRESSURE BACKFLOW PREVENTER
W-611	REDUCED PRESSURE BACKFLOW PREVENTER- LARGE DOMESTIC
W-615	2 ½" CITY PROVIDED CONSTRUCTION METER
W-616	FIRE HYDRANT GUARD POST
W-617	STANDARD FIRE HYDRANT INSTALLATION
W-620	STANDARD VALVE BOX ASSEMBLY
W-621	VALVE CAN ADJUSTING
W-625	WATER METER BOX ¾" TO 2"
W-626	STANDARD VAULT INSTALLATION
W-630	AUTOMATIC AIR RELEASE ASSEMBLY
W-635	TYPICAL THRUST BLOCK DETAILS 4" TO 12" DIA. FITTINGS
W-636	RESTRAINED JOINT DETAIL
W-640	SEWER AND WATER SEPARATION AND CROSSING REQUIREMENTS
W-641	WATER MAIN OFFSET/SIPHON
W-645	2" AND SMALLER SERVICE LATERAL ABANDONMENT
W-646	3" THROUGH 12" PIPELINE ABANDONMENT
W-647	TYPICAL TRENCH DETAIL
W-648	WARNING IDENTIFICATION AND TRACER WIRE INSTALLATION
W-649	CONNECTION TO EXISTING WATER MAIN
W-650	3" AND ABOVE GROUND METER AND BACKFLOW DETAIL
W-652	SAMPLING STATION DETAIL

LIST OF MATERIAL

ITEM	DESCRIPTION	FORD	MUELLER	JONES
1	DOUBLE STRAP SERVICE SADDLE	202B-NL	BR2B SERIES	J-979 SERIES
1a	DOUBLE STRAP SERVICE SADDLE	202BS-NL	BR2S SERIES	J-969 SERIES
2	CORPORATION STOP, 1", C.C. THREAD	FB-1000-Q-NL	B-25008N	E-1937 SG
3	ANGLE METER STOP, 1"	BA43 444WRQ NL	B-24258-3N	E-1963 WSG L/S
4	BUSHING, 1-1/4"x1" (FOR 5/8"x3/4" ONLY)	A-24NL	H10879N	E-128HM (1/2"x3/4"x1")
5	CUSTOMER METER COUPLING/BALL VALVE W/HANDLE	B13444WNL	B24351N	E-1908
6	METER BOX (SEE SEC. 2-10.7)			ARMORCAST/J&R
6a	CONCRETE COVER (SEE SEC 2-10.04)			
7	1/2" CRUSHED ROCK, (6" BASE)			
8	1" COPPER TUBE (NO SPLICES ALLOWED)			
9	WATER METER (SEE SECTION 2-11)			

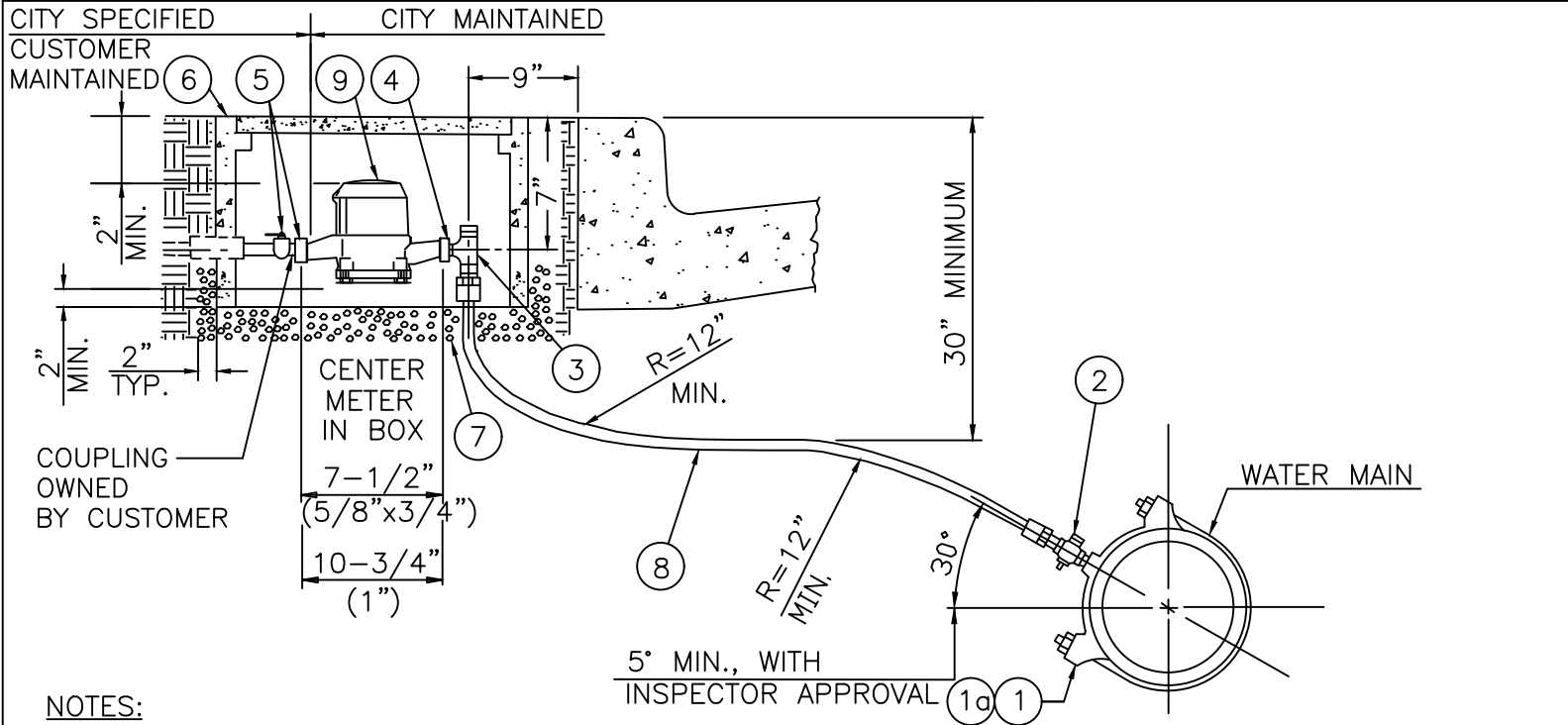

NOTES:

1. COPPER TUBE TO BE ONE CONTINUOUS PIECE. NO SPLICES PERMITTED.
2. INSTALL CORPORATION STOP WITH KEY UP.
3. TAPS SHALL BE MADE AT LEAST 24" FROM ANY OTHER TAP OR COUPLING.
4. STANDARD 1" WATER SERVICE IS USED FOR 3/4" AND 1" METERS.
5. SERVICE SADDLE AND CORPORATION STOP SHALL BE CC (AWWA) THREAD.
6. A TRAFFIC LOAD RATING COVER SHALL BE USED IN AREAS WITHOUT CURB, IN AREAS WITH ROLLED OR TYPE "F" CURB, OR WHERE THE METER IS LOCATED WITHIN 5- FEET OF THE BCR, ECR OR A DRIVEWAY APPROACH.
7. ANGLE METER STOPS SHALL BE PROVIDED WITH 360° TEE HEAD ROTATION AND LOCK WING.
8. NO PACK JOINTS ARE TO BE USED ANYWHERE ON ANY SERVICE
9. FOR EXISTING SERVICES W/ 6" COVER, SPECIAL ACCOMMODATION WILL HAVE TO BE MADE TO THE DISCRETION OF THE CITY ENGINEER.
10. 1/4 TURN FOR ALL CUSTOMER BALL VALVES
11. ITEM 4: 2 PER METER
12. ITEM 5: HANDLE B-20298 2"MIN.

REVISED	CITY OF WHITTIER- WATER DIVISION	DRAWN: HG
DATE 12/07/17		DESIGN: KAC
02/15/18		
03/19/19		
06/22/23		
	1" WATER SERVICE INSTALLATION	STD. NO
	APPROVED: 	W-601
	WATER MANAGER	DIRECTOR OF PUBLIC WORKS 
		SHEET <u>1</u> OF <u>1</u>

LIST OF MATERIAL

ITEM	DESCRIPTION	FORD	MUELLER	JONES
1	DOUBLE STRAP SERVICE SADDLE CC THREAD	202B-NL	BR2S SERIES	J-979 SERIES
1a	DOUBLE STRAP SERVICE SADDLE	202BS-NL	BR2S SERIES	J-969 SERIES
2	CORPORATION STOP, 2" CC THREAD	FB1100-7Q-NL	B-25008N	E-1937 SG
3	ANGLE METER STOP, 2"	BFA43-77WRQ-NL	B-24276-3N	E-1975 WSG L/S
4	90° ELL, COMP X COMP	L44-77QNL	H-15526N	E-2611 SG
5	METER FLANGE BRONZE x M.I.P. (FORD)			
6	METER BOX (SEE SEC. 2-10.7)			ARMORCAST/J&R
6a	CONC. COVER & LID (SEE SECTION 2-10.04)			
7	2" COPPER TUBE (COILED NOT ALLOWED)/PEX			
8	1/2" CRUSHED ROCK, (6" BASE)			
9	WATER METER(SEE SECTION 2-11)			
10	CUSTOMER BALL VALVE W/ HANDLE	BF13777WRNL	B-24337N	E-1913 F

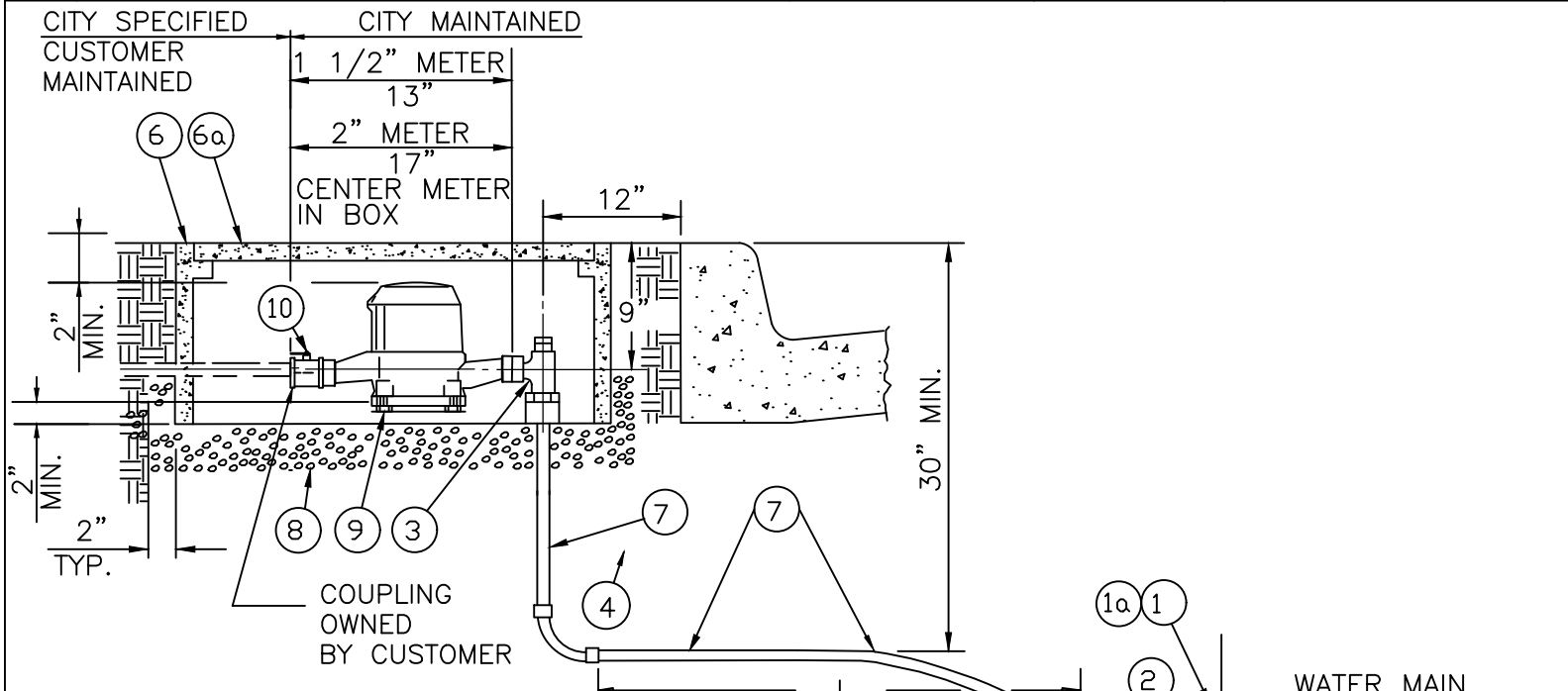

NOTES:

1. INSTALL CORPORATION STOP WITH KEY UP.
2. SERVICE SADDLE AND CORPORATION STOP SHALL BE CC THREAD.
3. TAPS SHALL BE MADE AT LEAST 24" FROM ANY OTHER TAP OR COUPLING.
4. STANDARD 2" SERVICE IS USED FOR 1-1/2" METER AND 2" METER.
5. A TRAFFIC LOAD RATING COVER SHALL BE USED IN AREAS WITHOUT CURB, IN AREAS WITH ROLLED OR TYPE "F" CURB, OR WHERE THE METER IS LOCATED WITHIN 5- FEET OF THE BCR, ECR OR A DRIVEWAY APPROACH. ANGLE METER STOPS SHALL BE PROVIDED WITH 360° TEE HEAD ROTATION.
6. TURBINE METER REQUIRES WATER ENGINEERING APPROVAL.
7. NO PACK JOINTS ARE TO BE USED ANYWHERE ON ANY SERVICE
8. FOR EXISTING SERVICES W/ 6" COVER, SPECIAL ACCOMMODATION WILL HAVE TO BE MADE TO THE DISCRETION OF THE CITY ENGINEER.
9. 1/4 TURN FOR ALL CUSTOMER BALL VALVE
10. ITEM 10: HANDLE H-10298
11. FOR 2' SERVICE & 1-1/2" METER ADD FORD: A67-NL FLXFL (710J67DH) OR APPROVED EQUAL

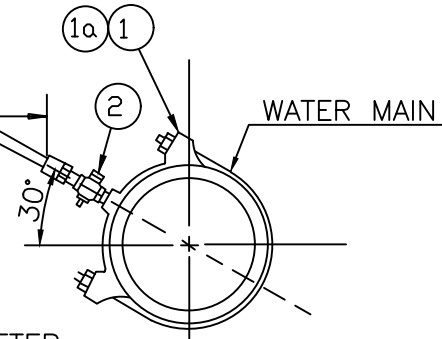

REVISED	CITY OF WHITTIER- WATER DIVISION	DRAWN: HG
DATE 12/07/17		DESIGN: KAC
03/19/19	2" WATER SERVICE INSTALLATION	STD. NO
06/22/23		W-602
	APPROVED: 	
	WATER MANAGER	DIRECTOR OF PUBLIC WORKS
		SHEET 1 OF 1

LIST OF MATERIAL

ITEM	DESCRIPTION
1	MJ TEE-FLANGED OUTLET, DIP
2	GATE VALVE-FLG X MJ, MUELLER WITH VALVE CAN PER SECTION 2-04
3	LATERAL-DUCTILE IRON PIPE PER SECTION 2-01
4	CAP-MJ W/WEDGE ACTION RESTRAINING DEVICE & W/2" OUTLET
5	MECHANICAL JOINTS SHALL BE RESTRAINED PER SECTION 2-03

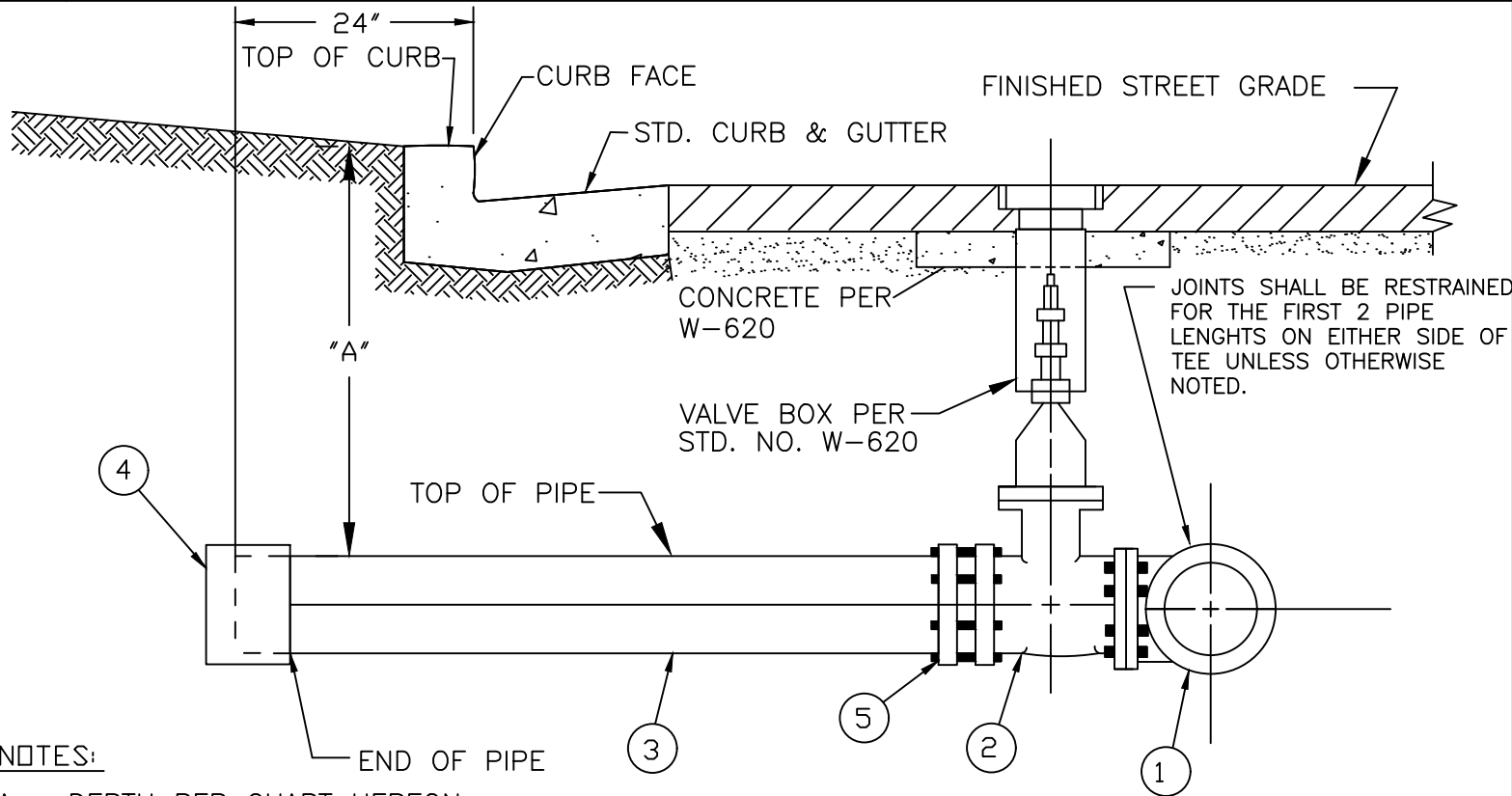

NOTES:

- A. DEPTH PER CHART HEREON
- 1. TAPPING SLEEVES, WHEN INDICATED PER PLAN OR AS DIRECTED BY UTILITY SHALL BE PER SPECIFICATION SECT. 2-08. TAPPING VALVES 12" AND SMALLER SHALL BE RESILIENT WEDGE VALVES.
- 2. PIPE, VALVE, TEE OUTLET AND CAP SHALL BE OF SAME NOMINAL DIAMETER, EXCEPT FOR 3" METER WHEN ALL SHALL BE 4".
- 3. USE FIELD LOK GASKETS OR APPROVED EQUAL REQUIRED FOR ALL PUSH ON JOINTS. SEE NOTE 6 FOR PVC PIPE REQUIREMENT.
- 4. PVC WATER MAIN CONSTRUCTION SHALL BE PRE-APPROVED BY THE UTILITY PER SECTION 2-02.
- 5. MECHANICAL JOINT THRUST RESTRAINT FOR PIPE SHALL BE RESTRAINED AS PER SECT. 2-03.
- 6. FOR PVC LATERAL PIPE, CONNECT AND RESTRAIN PLAIN END PIPE USING DUCTILE IRON SOLID SLEEVE WITH RESTRAINTS AS PER NOTE 5.
- 7. ALL D.I. PIPELINE, FITTINGS AND VALVES SHALL BE ENCASED IN 8 MIL MINIMUM POLYETHELENE PER SECTION 2-01.

STANDARD DEPTH		
METER	"A"	MIN PIPE SIZE
3"	36"	4"
4"	36"	4"
6"	42"	6"
DUAL 6"	42"	8"
8"	SPECIAL DESIGN	

REVISED	
DATE	12/07/17
	03/19/19
	06/22/23

CITY OF WHITTIER- WATER DIVISION

3" THROUGH 8" METER LATERAL INSTALLATION

APPROVED: 
WATER MANAGER



DIRECTOR OF PUBLIC WORKS

DRAWN: HG
DESIGN: KAC

STD. NO
W-603
SHEET 1 OF 1

LIST OF MATERIAL

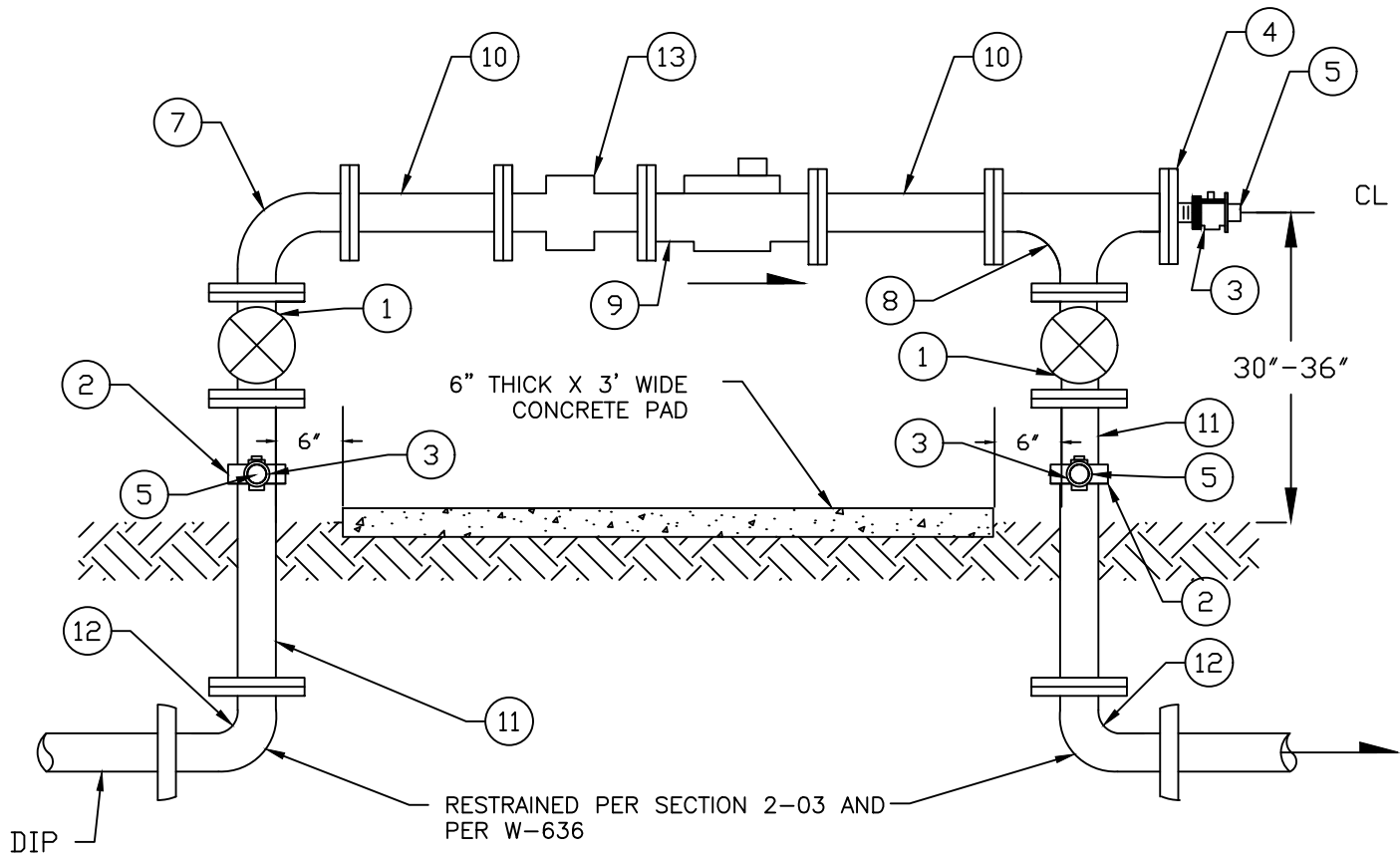
ITEM	DESCRIPTION	QTY.
1	GATE VALVE, FLXFL WITH HANDWHEEL	2
2	DOUBLE STRAP SERVICE SADDLE, 2" OUTLET (FOR BYPASS)* IP THREAD	2
3	2" BALL VALVE M.I.P. X F.I.P. WITH LOCK WINGS	3
4	BLIND FLANGE D.I. WITH 2" OUTLET IN CENTER IP THREAD	1
5	2" BRASS PLUG	3
6	NOT USED	1
7	90° ELBOW FLXFL, D.I.	1
8	TEE, FLXFLXFL., D.I.	1
9	CITY SUPPLIED WATER METER, REGISTER IN CUBIC FEET	1
10	SPOOL, LENGTH IS 5 TIMES PIPE DIAMETER, FLXFL, D.I.	2
11	SPOOL, FLXFL, LENGTH VARIES, D.I.	2
12	90° ELBOW, MJXMJ, D.I., RESTRAIN MJ FITTING	2
13	CITY SUPPLIED BRASS SCREEN UNIT	1



NOTES:

EASEMENT REQUIRED 3' BEHIND SIDEWALK, 3' BEHIND METER PIPING, AND 3' FROM CENTERLINE ON EACH SIDE OF THE METER

REVISED	
DATE	12/07/17
	03/19/19
	06/22/23

CITY OF WHITTIER- WATER DIVISION

ABOVE GROUND METER INSTALLATION 3" & LARGER

APPROVED:  WATER MANAGER

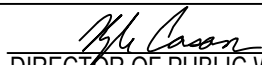
 DIRECTOR OF PUBLIC WORKS

DRAWN: HG
DESIGN: KAC
STD. NO
W-604
SHEET 1 OF 1

LIST OF MATERIAL

ITEM	DESCRIPTION	QTY.
1	GATE VALVE, FLXMJ	2
2	D.I. TEE FL	1
3	OCTAVE WATER METER, REGISTER IN CUBIC FEET (INSTALLATION PER MANUFACTURERS RECOMMENDATIONS)	1
4	PRECAST CONCRETE VAULT WITH HINGED BILCO LID AND DROP READING LID AS APPROVED BY CITY ENGINEER. VAULT SHALL HAVE CHANNEL DRAIN. SIZE SHALL BE DETERMINED BY ENGINEER AND APPROVED BY CITY.	1
5	DOUBLE STRAPS SERVICE SADDLE, BRASS 2" OUTLET (FOR BYPASS) IP THREAD	2
6	2" BRASSPLUG	2
7	2" BALL VALVE M.I.P. X F.I.P. WITH LOCK WINGS	1
8	SENSUS BRASS SCREEN UNIT	1
9	BLIND FLANGE WITH 2" IP THREAD	1
10	1/2" CRUSHED ROCK, (12" BASE) EXTEND 6" INTO VAULT	-
11	SUPPORT, ADJUSTABLE PIPE, FLAT SUPPORT	2

NOTE: THIS STANDARD IS ONLY ALLOWED ON SPECIAL CIRCUMSTANCE & APPROVAL IS
REQUIRED BY THE CITY ENGINEER.

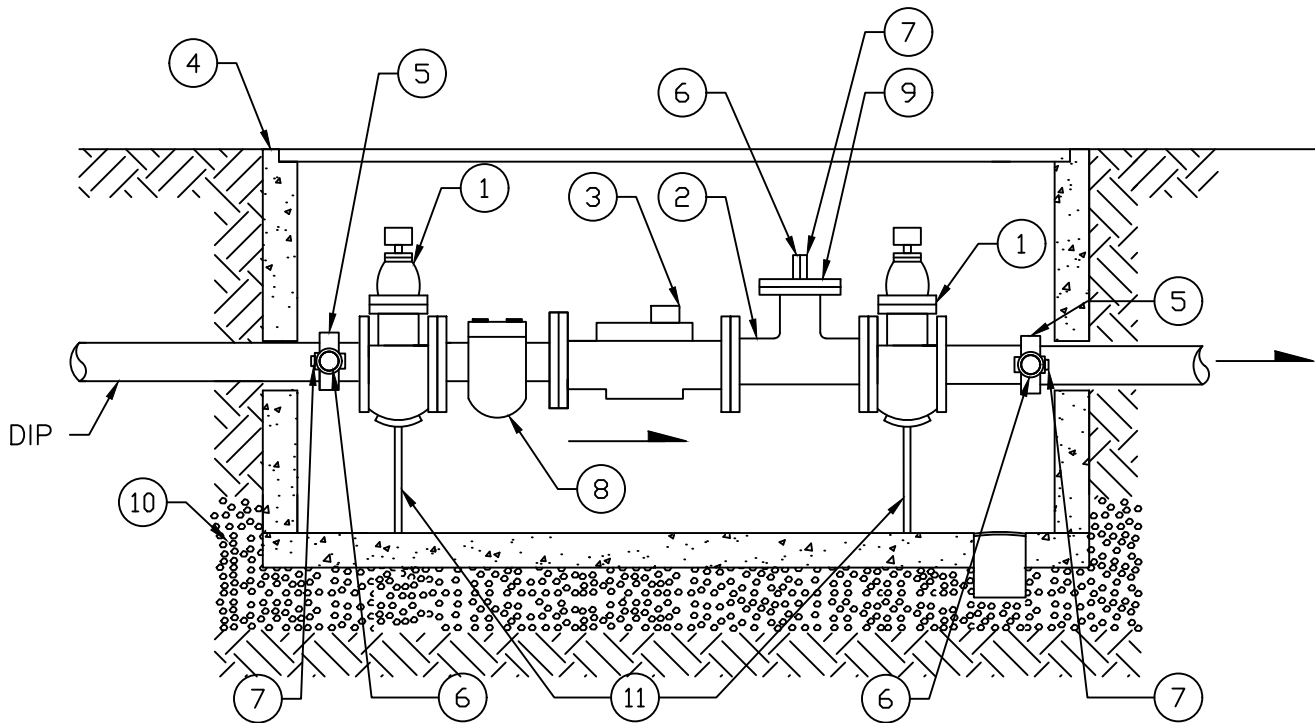

REVISED
DATE 02/15/18
03/19/19
06/22/23

CITY OF WHITTIER- WATER DIVISION

**UNDER GROUND METER
INSTALLATION 3" + LARGER**

APPROVED:  WATER MANAGER

 DIRECTOR OF PUBLIC WORKS

DRAWN: HG DESIGN: KAC
STD. NO W-605
SHEET <u>1</u> OF <u>1</u>

LIST OF MATERIAL

ITEM	DESCRIPTION	QTY.
1	SPOOL MJxMJ D.I.	2
2	90° ELBOW FLxFL D.I.	2
3	GATE VALVE, FLxFL OUTSIDE SCREW AND YOLK	2
4	SUPPORT, ADJUSTABLE PIPE, FLAT SUPPORT	2
5	90° ELBOW, MJxMJ, D.I., RESTRAIN MJ FITTINGS	2
6	6" CONCRETE PAD W.W.F. 1.6x1.6	
7	FACTORY INSTALLED BY-PASS METER, DOUBLE CHECK VALVE (DCV), AND ASSOCIATED PIPING	1

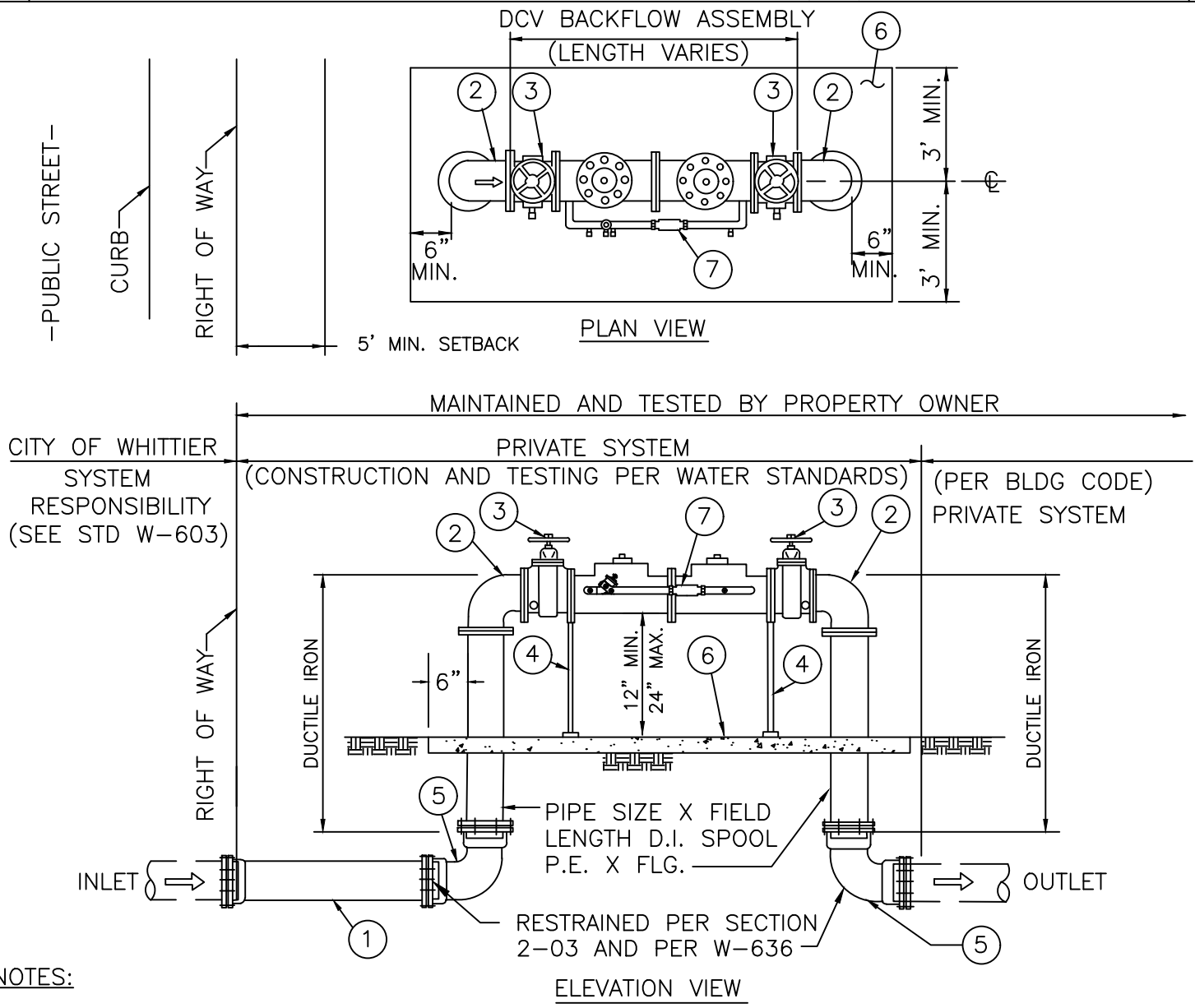

NOTES:

- EASEMENT REQUIRED 3' BEHIND SIDEWALK, 3' BEHIND METER PIPING, AND 3' FROM CENTERLINE ON EACH SIDE OF THE METER.
- ALL BACKFLOW DEVICES SHALL BE APPROVED BY USC FOUNDATION FOR CROSS CONNECTION.
- BF MUST BE TESTED BY LA COUNTY CERTIFIED BACKFLOW TESTER. TESTERS MUST MAINTAIN AN ACTIVE WHITTIER BUSINESS LICENSE.
- LOCATION AND INSTALLATION SHALL BE PER PLAN SUBMITTED TO AND APPROVED BY THE UTILITY.

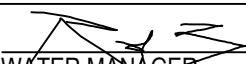
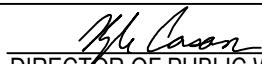
REVISED DATE 12/07/17 03/19/19 06/22/23	CITY OF WHITTIER- WATER DIVISION FIRE LINE DOUBLE CHECK DETECTOR ASSEMBLY	DRAWN: HG DESIGN: KAC
APPROVED:  WATER MANAGER	 DIRECTOR OF PUBLIC WORKS	STD. NO W-606 SHEET 1 OF 1

LIST OF MATERIAL

ITEM	DESCRIPTION
1	BACKFLOW PREVENTION DEVICE, USC APPROVED TYPE
2	WYE STRAINER, BRASS
3	BRASS UNION
4	RISER AND NIPPLES – BRASS OR COPPER
5	90° ELBOW, MJxMJ, D.I., RESTRAIN MJ FITTINGS

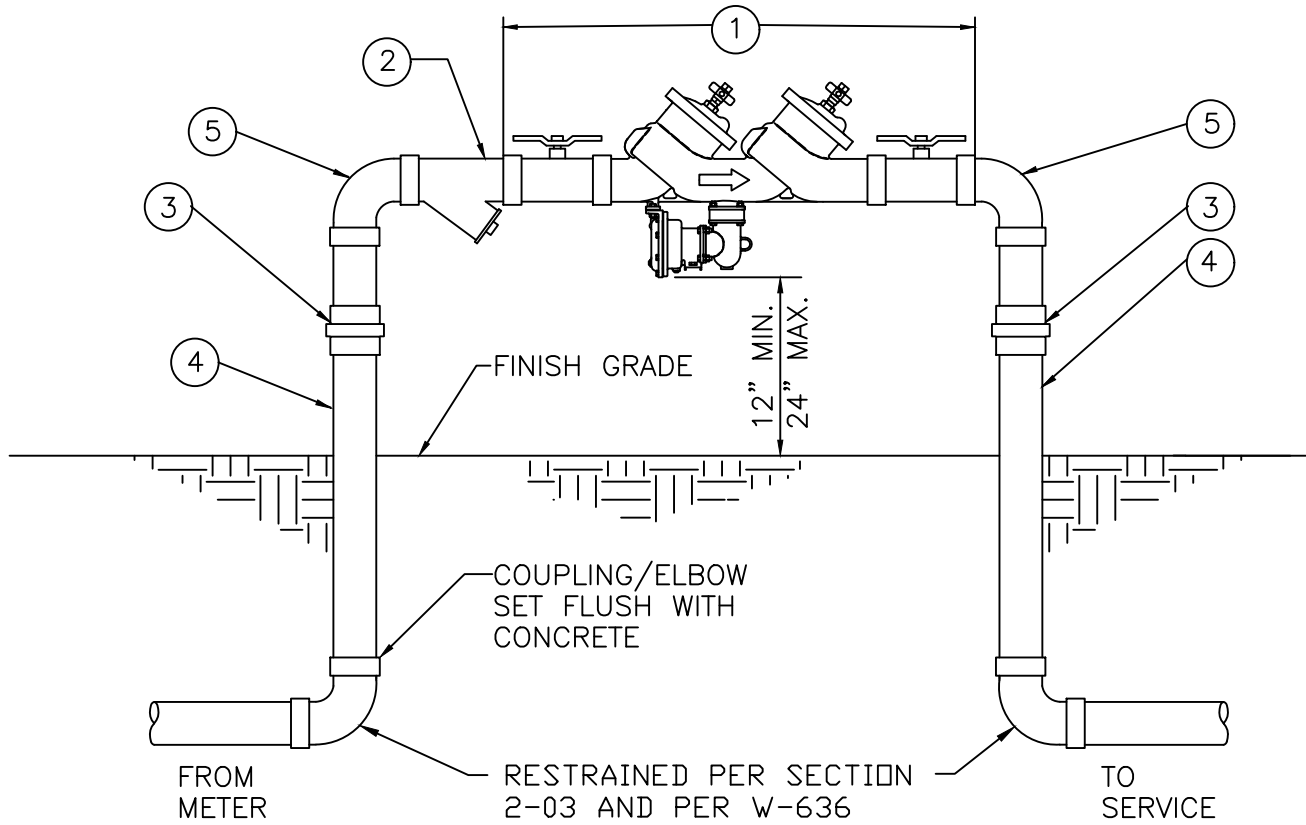

NOTES:

1. THE BACKFLOW PREVENTER ASSEMBLY SHALL CONSIST OF AN APPROVED REDUCED PRESSURE ASSEMBLY. ASSEMBLY SHALL BE APPROVED BY USC FOUNDATION FOR CROSS CONNECTION.
2. LOCATION AND INSTALLATION SHALL BE PER PLAN AS SUBMITTED TO AND APPROVED BY THE UTILITY.
3. NO CONNECTIONS TO BE MADE BETWEEN METER AND BACKFLOW PREVENTER.
4. SECURITY ENCLOSURE (OPTIONAL) SHALL BE AS SPECIFIED PER PROJECT PLAN OR AS DIRECTED BY THE CITY.
5. 12" ABOVE FINISHED GRADE
6. 12" AWAY FROM ANY STRUCTURE
7. MUST BE LOCATED AS CLOSE, AS PRACTICAL TO WATER METER
8. AFTER INSTALLATION, BACKFLOW SHALL BE TESTED BY A LOS ANGELES COUNTY CERTIFIED BACKFLOW TESTER. TESTERS MUST MAINTAIN AN ACTIVE CITY OF WHITTIER BUSINESS LICENSE.

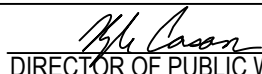
REVISED DATE 12/07/17 02/15/18 03/19/19 06/22/23	CITY OF WHITTIER- WATER DIVISION	DRAWN: HG DESIGN: KAC
	REDUCED PRESSURE BACKFLOW PREVENTER $\frac{3}{4}$ " THROUGH 2"	STD. NO W-610
APPROVED:  WATER MANAGER	 DIRECTOR OF PUBLIC WORKS	SHEET <u>1</u> OF <u>1</u>

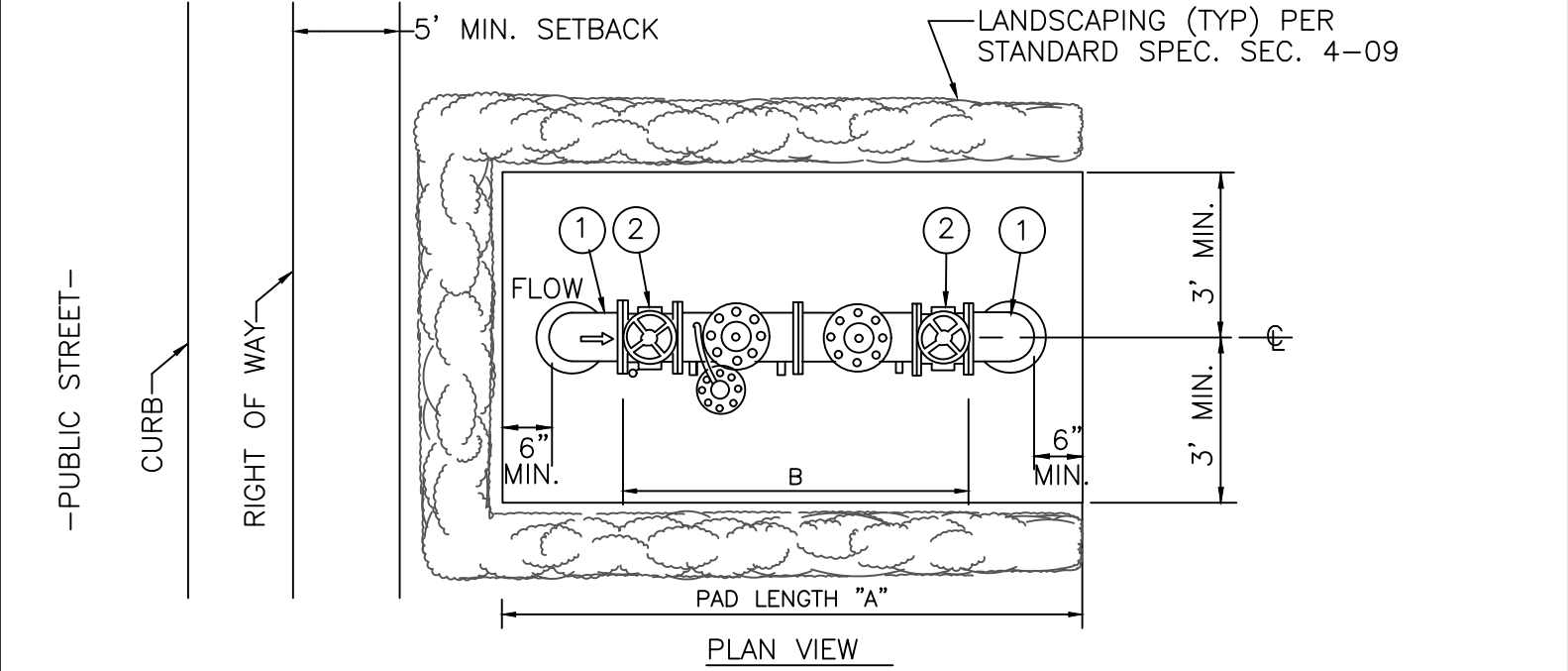

PLAN VIEW

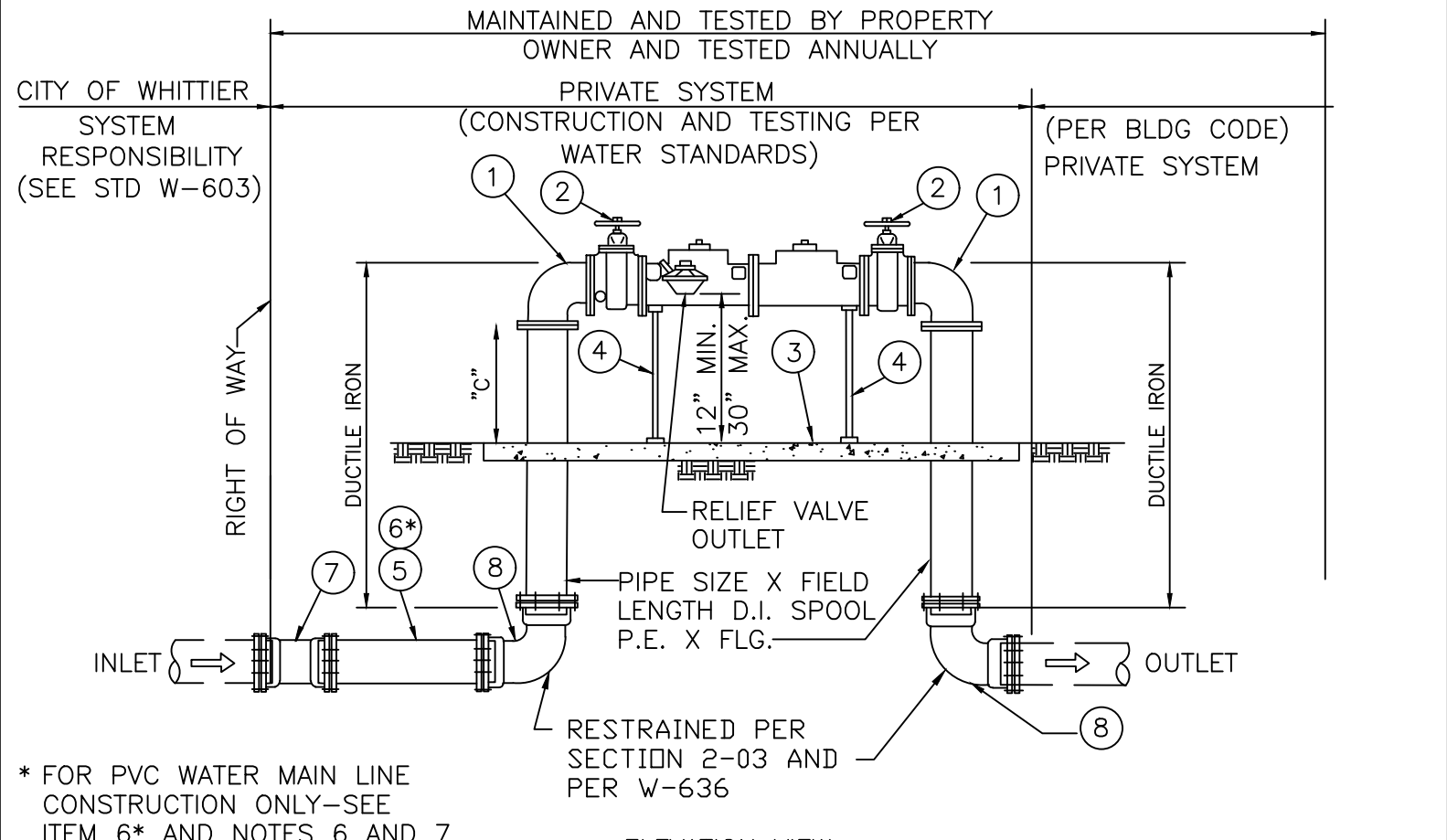

ELEVATION VIEW

* FOR PVC WATER MAIN LINE CONSTRUCTION ONLY—SEE ITEM 6* AND NOTES 6 AND 7 ON SHEET 2

REVISED	
DATE	12/07/17
	03/19/19
	06/22/23

CITY OF WHITTIER- WATER DIVISION
REDUCED PRESSURE BACKFLOW PREVENTER
LARGE DOMESTIC ONLY

APPROVED:  WATER MANAGER

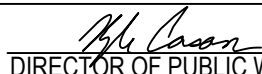
 DIRECTOR OF PUBLIC WORKS

DRAWN: HG
DESIGN: KAC
STD. NO
W-611
SHEET 1 OF 2

LIST OF MATERIAL

ITEM	DESCRIPTION
1	SR 90° BEND, D.I., FLGxFLG.
2	RESILIENT WEDGE VALVE, FLGxFLG, HAND WHEEL (SEE SPECIFICATION SECTION 2-06 FOR REQUIREMENTS).
3	CONCRETE PAD 4" THICK, SIZE AS INDICATED HEREIN; CLASS 520-C-2500 CONCRETE
4	SUPPORT, ADJUSTABLE PIPE, FLAT SUPPORT
5	PIPE SIZE X FIELD LENGTH D.I. SPOOL, P.E.xP.E.
6*	IN LIEU OF ITEM 5, PIPE SHALL BE AWWA C900 PVC CLASS 200 (DR 14), P.E.xP.E. (SEE NOTES 6 AND 7)
7	D.I. SOLID SLEEVE M.J.xM.J. (SEE NOTE 5); M.J.'S SHALL BE RESTRAINED PER SECTION 2-12.01.
8	D.I. 90° BEND, M.J.xM.J. (2 TYP.), MJ'S SHALL BE RESTRAINED AS PER SECT, 2-03

LATERAL SIZE	A	B (MAX)	C
4"	7.0'	4'-3"	14"
6"	8.5'	5'-3"	14"
8"	9.5'	6'-4"	13.5"
10"	11.5'	7'-5"	12"

NOTES:

- ALL EXPOSED PIPE AT THE 90° BENDS SHALL BE DUCTILE IRON PER SECTION 2-01.
- ALL PIPE FITTINGS AND APPURTENANCES (GASKETS, NUTS, BOLTS, RESTRAINTS) SHALL COMPLY WITH SECTIONS 2-03 & 2-07.
- SEE STANDARD DRAWING W-604 FOR ABOVE GROUND ASSEMBLY INSTALLATION REQUIREMENTS.
- COMPLETED ASSEMBLY SHALL BE PAINTED PER SECTION 2-14.
- ITEM 7 IS REQUIRED IF BACKFLOW DEVICE ASSEMBLY IS NOT INSTALLED AT THE SAME TIME OF THE LATERAL INSTALLATION.
- PVC WATER MAIN CONSTRUCTION SHALL BE PRE-APPROVED BY THE UTILITY PER SECTION 2-02.
- MECHANICAL JOINT RESTRAINT FOR PIPE SHALL BE RESTRAINED AS PER SECT. 2-03.
- ASSEMBLY SHALL BE APPROVED BY USC FOUNDATION FOR CROSS CONNECTION.
- LOCATION AND INSTALLATION SHALL BE PER PLAN AS SUBMITTED AND APPROVED BY THE UTILITY.
- AFTER INSTALLATION, BACKFLOW SHALL BE TESTED BY AN LA COUNTY CERTIFIED BACKFLOW TESTER. TESTER MUST MAINTAIN AN ACTIVE WHITTIER BUSINESS LICENSE.

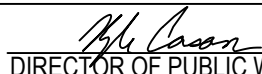
REVISED DATE <u>12/07/17</u> <u>03/19/19</u> <u>06/22/23</u> _____ _____ _____	CITY OF WHITTIER- WATER DIVISION REDUCED PRESSURE BACKFLOW PREVENTER LARGE DOMESTIC ONLY	DRAWN: HG DESIGN: KAC	
	APPROVED:  WATER MANAGER	 DIRECTOR OF PUBLIC WORKS	STD. NO W-611 SHEET <u>2</u> OF <u>2</u>

LIST OF MATERIAL

ITEM	DESCRIPTION
1	SWIVEL ADAPTER: 2 1/2" FEMALE HOSE THREAD x 3" M.I.P. THREAD BRASS. HALPRIN SUPPLY CO. SA-10 OR APPROVED EQUAL
2	FIRE HYDRANT METER 3" MASTER OR KENT
3	BRASS REDUCER 3" M.I.P. THREAD HEX TYPE x 2 1/2" M.I.P. THREAD
4	CITY APPROVED BACKFLOW PREVENTER
5	SUPPORT, ADJUSTABLE PIPE, FLAT SUPPORT
6	2-1/2" NO LEAD, BRASS GATE VALVE

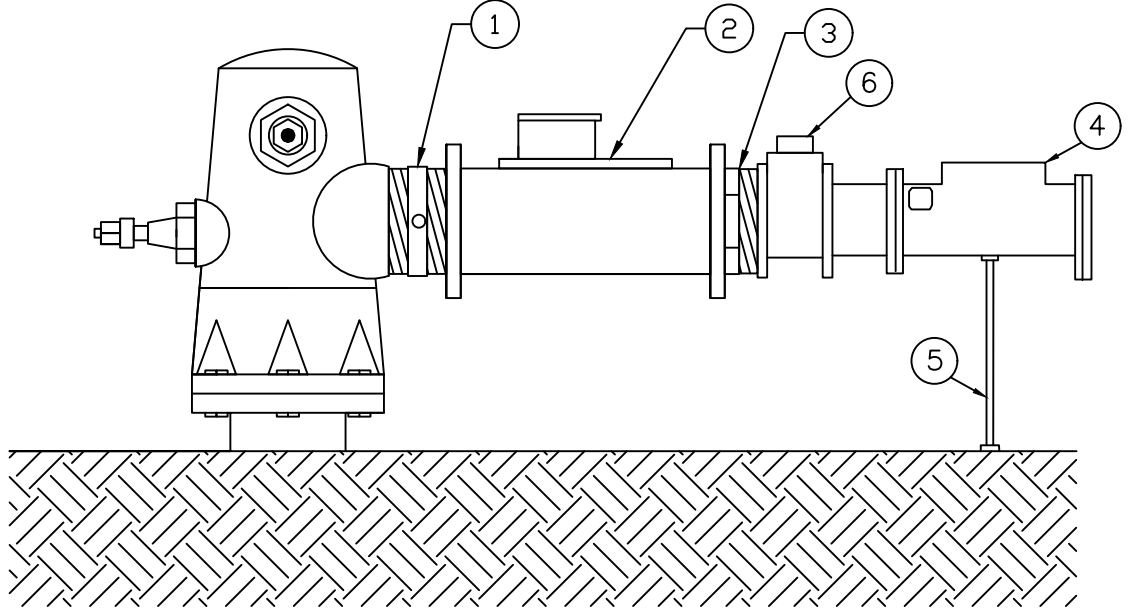

NOTES:

1. OPENING AND CLOSING OF HYDRANT IS PERMITTED ONLY WITH A HYDRANT WRENCH. CITY PROVIDED GATE VALVE WILL BE USED TO CONTROL WATER FLOW.
2. SERVICE MAY BE MOVED FROM ONE LOCATION TO ANOTHER ONLY BY THE WATER DIVISION.
3. BACKFLOW DEVICES MAY BE REQUIRED FOR CERTAIN USES. TRUCKS MUST HAVE AN AIR GAP SEPARATION ABOVE THE OVERFLOW OF THE WATER TANK.
4. SERVICE CONNECTION MAY BE TERMINATED AT ANY TIME AT THE DISCRETION OF THE WATER DIVISION.
5. CHARGES FOR LOSS OR DAMAGE TO ANY SERVICE MATERIAL WILL BE BASED UPON CURRENT PRICES.

REVISED
DATE 12/07/17
03/19/19
06/22/23

CITY OF WHITTIER- WATER DIVISION

2 1/2" CITY PROVIDED CONSTRUCTION METER

APPROVED:  WATER MANAGER

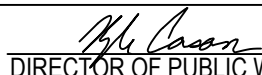
 DIRECTOR OF PUBLIC WORKS

DRAWN: HG DESIGN: KAC
STD. NO W-615
SHEET <u>1</u> OF <u>1</u>

OMIT REAR GUARD POSTS
ON INSTALLATIONS NOT
REQUIRING PROTECTION
FROM THE REAR

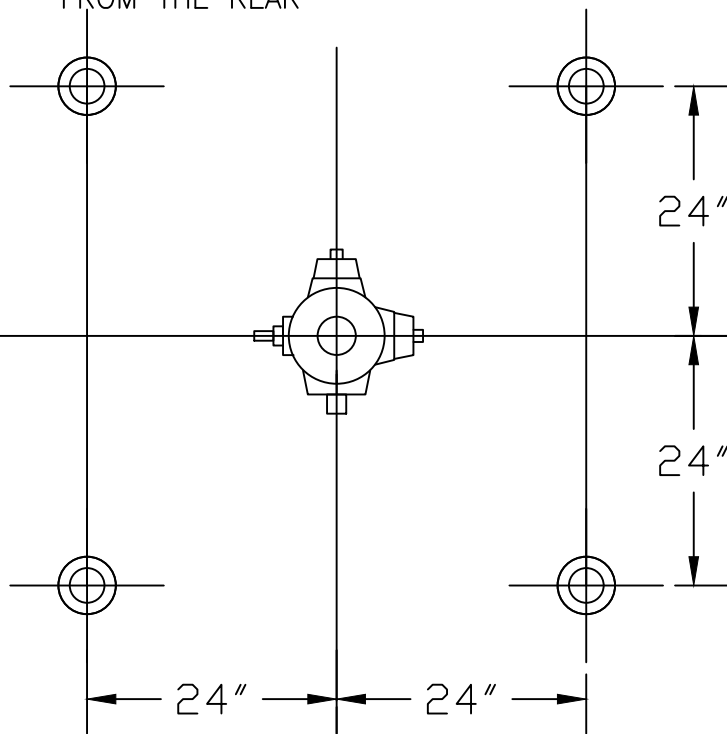

PLAN

NOTES :

1. TO BE INSTALLED FOR HYDRANTS OR OTHER CITY WATER FACILITIES ADJACENT TO STREETS WITHOUT CURBS, WITH ROLLED OR TYPE 'F' CURB, OR WITHIN 4 FEET OF PARKING LOT CURB OR CURB STOPS.
2. GUARD POSTS SHALL BE PAINTED IN ACCORDANCE WITH SECTION 2-13.
3. REFLECTIVE TAPE REQUIRED FOR COLORS OTHER THAN SAFETY YELLOW.
4. FOR ALL CASES, THE LOCATION OF GUARD POSTS SHALL MEET ADA REQUIREMENT THAT A MINIMUM 48-INCH CLEARANCE BE MAINTAINED FROM ANY OBSTRUCTION IN THE WALK.
5. GUARD POSTS SHALL BE LOCATED A MINIMUM 5- FEET FROM BCR, ECR OR DRIVEWAY APPROACH.
7. FOR ROLLED CURBS OR NO CURBS, THE DISTANCE FROM THE EDGE OF PAVEMENT TO THE GUARD POSTS SHALL BE AS DIRECTED BY THE ENGINEER.

FILL POST WITH
CONCRETE (ROUNDED
ON TOP)

TWO 3" WIDE BANDS OF SCOTCHLITE, HIGH
INTENSITY GRADE #5870 SILVER REFLECTIVE
SHEETING SHALL BE PLACED AROUND POSTS

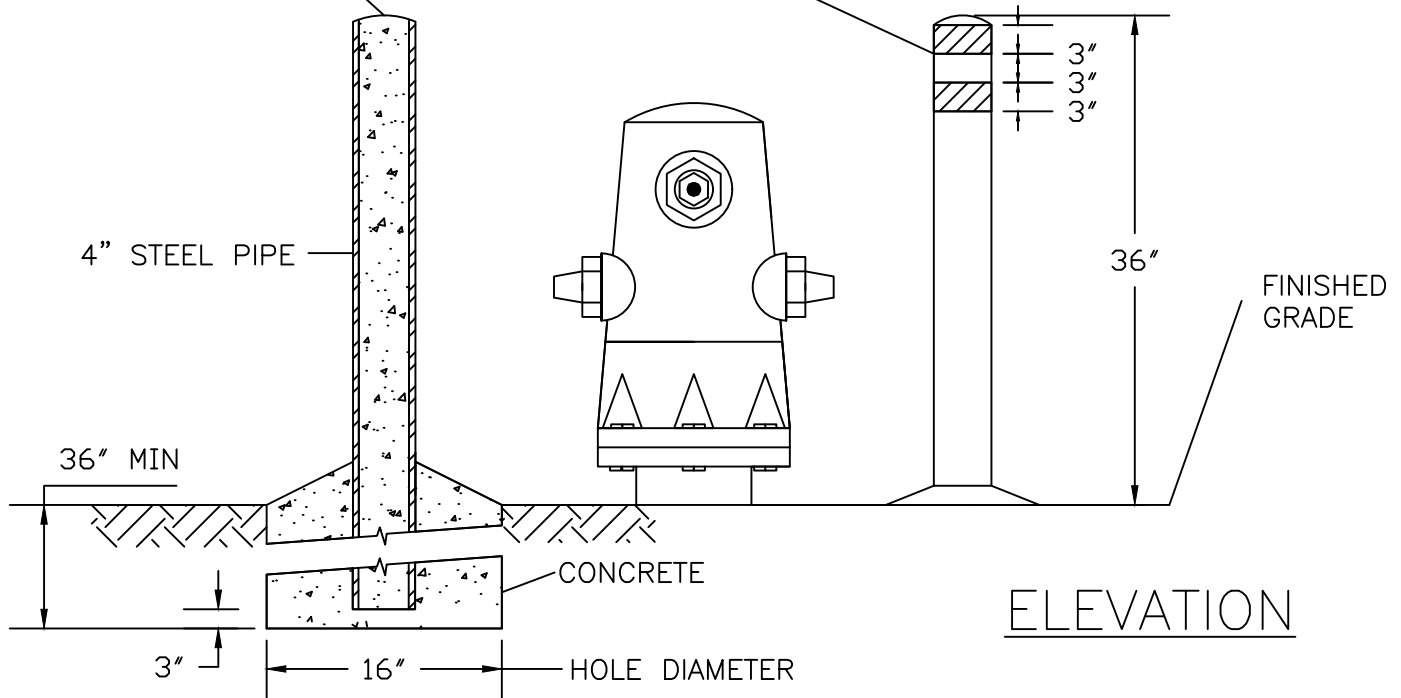

ELEVATION

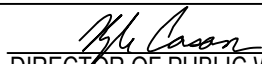
REVISED DATE <u>12/07/17</u> <u>06/22/23</u> 	CITY OF WHITTIER- WATER DIVISION FIRE HYDRANT GUARD POST	DRAWN: HG DESIGN: KAC STD. NO W-616 SHEET <u>1</u> OF <u>1</u>
APPROVED:  WATER MANAGER	 DIRECTOR OF PUBLIC WORKS	

LIST OF MATERIAL

ITEM	DESCRIPTION
1	TEE (MAIN SIZE X 6") MJxMJxFL, RESTRAINED AS PER SECT. 2-03.
2	GATE VALVE, FLxMJ, MUELLER, RESTRAINED AS PER SECT. 2-03.
3	D.I.P. 6", LENGTH VARIES, RESTRAINED AS PER SECT. 2-03.
4	FIRE HYDRANT BURY, MJ INLET 6"x42" OR 6"x48"
5	FIRE HYDRANT, JONES
6	2-WAY REFLECTING BLUE PAVEMENT MARKER

NOTES:

1. FIRE HYDRANTS SHALL BE PURCHASED FROM MANUFACTURER AND PAINTED IN ACCORDANCE WITH SECTION 2-13.
2. FIRE HYDRANTS SHALL HAVE NATIONAL STANDARD HOSE THREADS AND OUTLETS FACED AT A 45° ANGLE TO THE CURB FACE.
3. CONTRACTOR SHALL USE ADDITIONAL RESTRAINED BENDS NECESSARY TO AVOID OTHER EXISTING OR PROPOSED UTILITIES WHEN REQUIRED.
4. FOR ALL CASES, THE LOCATION OF FIRE HYDRANT SHALL MEET ADA REQUIREMENT THAT A MINIMUM 48-INCH CLEARANCE BE MAINTAINED FROM ANY OBSTRUCTION IN THE WALK.
5. FIRE HYDRANT SHALL BE LOCATED A MINIMUM OF 5-FEET FROM BCR, ECR OR DRIVEWAY APPROACH.
6. FOR ROLLED CURBS THE DISTANCE FROM THE EDGE OF THE PAVEMENT TO THE FIRE HYDRANT SHALL BE AS DIRECTED BY THE ENGINEER.
7. PVC WATER MAIN CONSTRUCTION SHALL BE PRE-APPROVED BY THE UTILITY PER SECTION 2-02. 1
8. MECHANICAL JOINT RESTRAINT FOR PVC PIPE SHALL BE 2000PV RESTRAINT BY EBBA IRON OR EQUAL AS PER SECT. 2-03 FOR PVC.
9. TWO-WAY REFLECTIVE BLUE PAVEMENT MARKER, STIMSONITE, ON HYDRANT STATIONING. PLACEMENT ON CL FOR TWO-WAY STREETS AND ON LANE LINE CLOSEST TO HYDRANT LATERAL VALVE FOR MULTI-LANE STREETS.

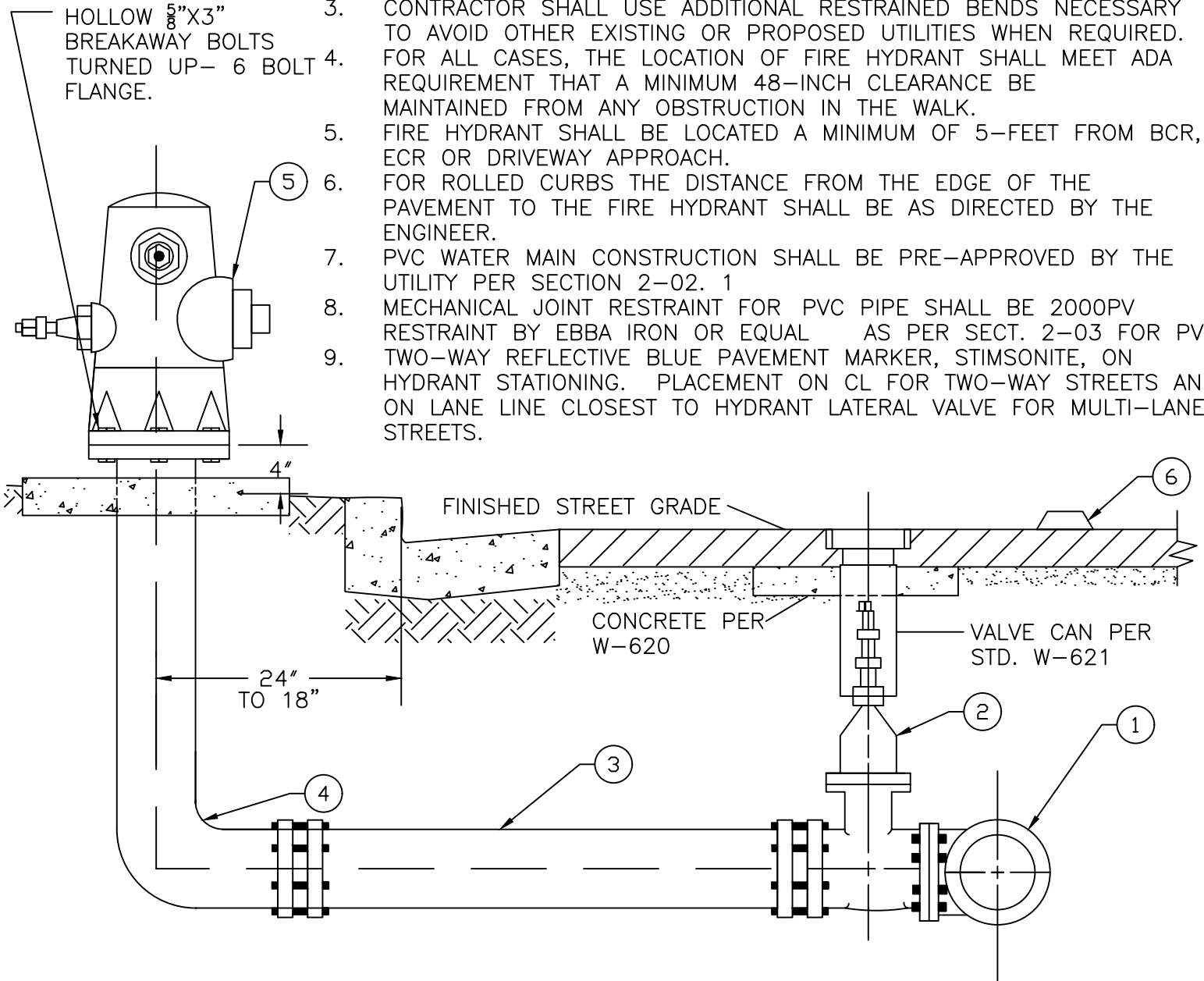

REVISED	
DATE	12/07/17
	06/22/23

CITY OF WHITTIER- WATER DIVISION

STANDARD FIRE HYDRANT INSTALLATION

APPROVED:  WATER MANAGER

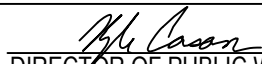
 DIRECTOR OF PUBLIC WORKS

DRAWN: JG
DESIGN: KAC
STD. NO
W-617
SHEET 1 OF 1

LIST OF MATERIAL

ITEM	DESCRIPTION
1	EISEL ENTERPRISES NO. 10, TAYLOR MARK V OR (OR APPROVED EQUAL) VALVE BOX LID MARKED WATER, LID MUST BE DEEP SKIRT (W106C) 28 LBS
2	ONE PIECE 8" (SDR 35) PVC RISER PIPE
3	RISER OPENING FOR TRACER WIRE

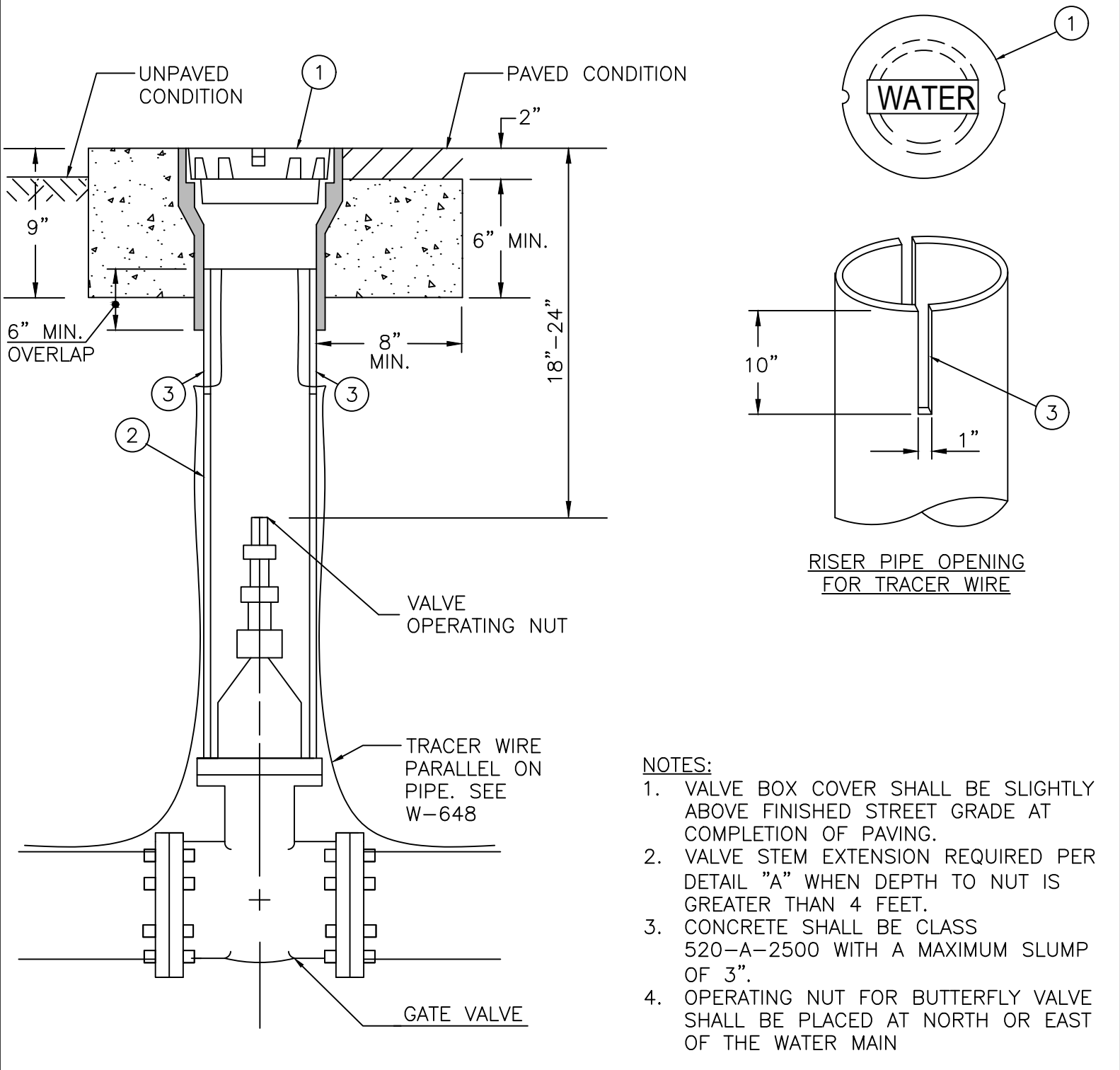

- NOTES:**
1. VALVE BOX COVER SHALL BE SLIGHTLY ABOVE FINISHED STREET GRADE AT COMPLETION OF PAVING.
 2. VALVE STEM EXTENSION REQUIRED PER DETAIL "A" WHEN DEPTH TO NUT IS GREATER THAN 4 FEET.
 3. CONCRETE SHALL BE CLASS 520-A-2500 WITH A MAXIMUM SLUMP OF 3".
 4. OPERATING NUT FOR BUTTERFLY VALVE SHALL BE PLACED AT NORTH OR EAST OF THE WATER MAIN

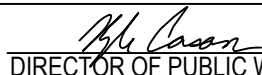
REVISED DATE 12/07/17 03/19/19 06/22/23	CITY OF WHITTIER- WATER DIVISION	DRAWN: HG DESIGN: KAC
APPROVED:  WATER MANAGER	STANDARD VALVE BOX ASSEMBLY	STD. NO W-620 SHEET 1 OF 2
	 DIRECTOR OF PUBLIC WORKS	

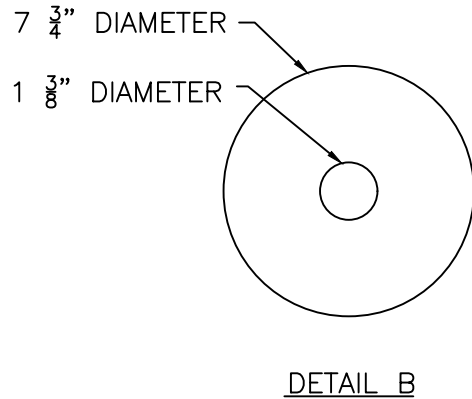
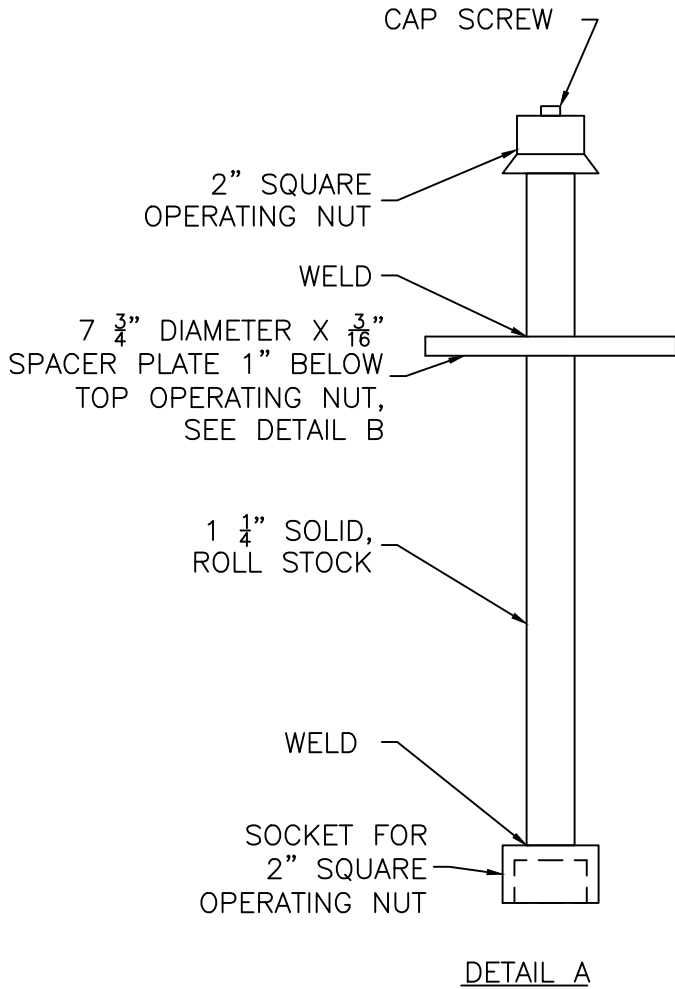

NOTES:

1. TERMINATE EXTENSION 24" TO 35" FROM FINISHED STREET GRADE.
2. NO VALVE STEM EXTENSION SHALL BE LESS THAN 2 FEET IN LENGTH.
3. PROVIDE ADDITIONAL SPACER PLATE WHEN DISTANCE TO BOTTOM SOCKET EXCEEDS 5'.
5. VALVE STEM EXTENSION SHALL BE OF SOLID DESIGN. PINED COUPLES ARE UNACCEPTABLE

REVISED	
DATE	12/07/17
	06/22/23

CITY OF WHITTIER- WATER DIVISION

STANDARD VALVE BOX ASSEMBLY

APPROVED:



 WATER MANAGER

 DIRECTOR OF PUBLIC WORKS

DRAWN: HG
 DESIGN: KAC

STD. NO
W-620

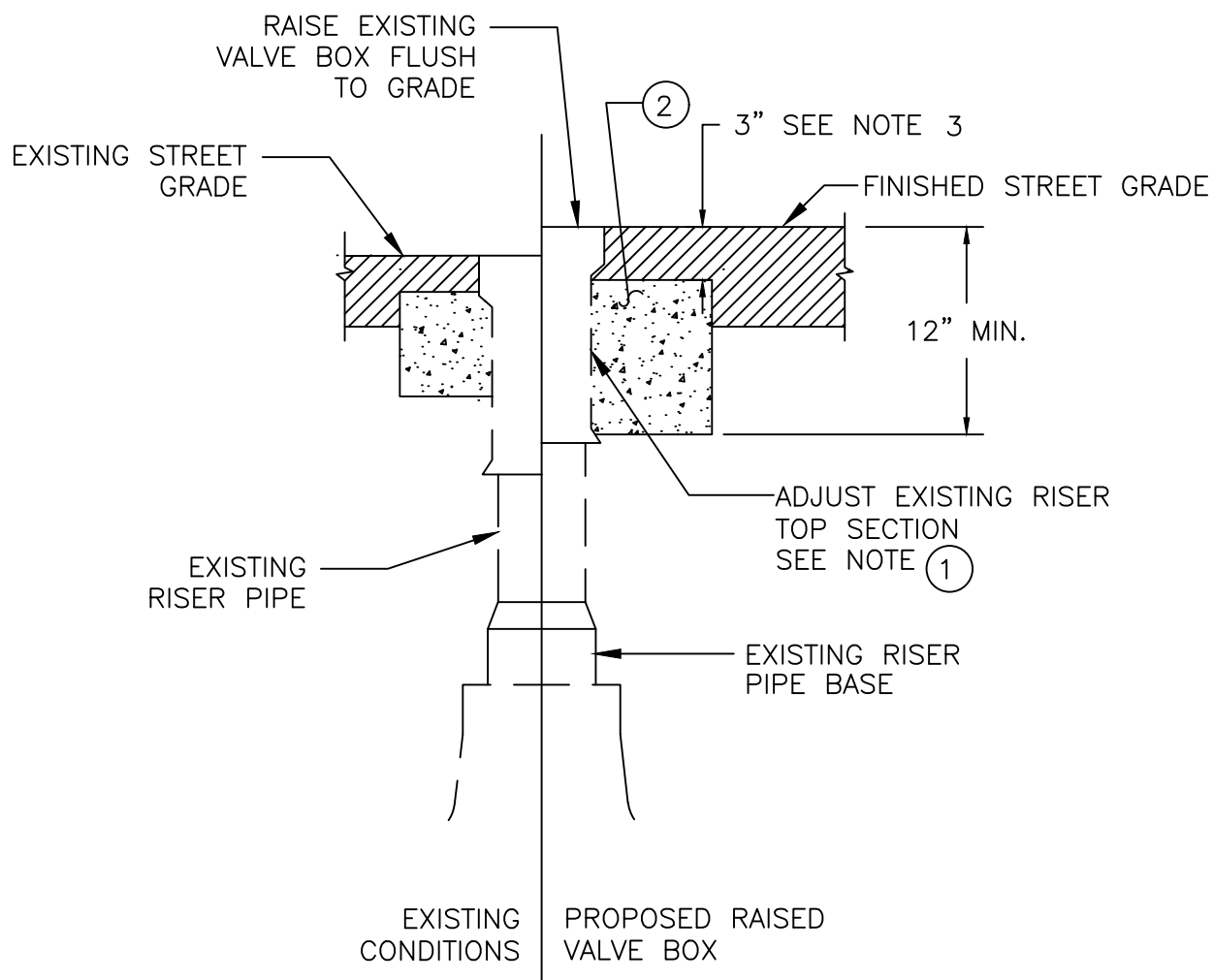
SHEET 2 OF 2



CASE 1

NOTES:

- 1 CONTRACTOR TO EXPOSE THE EXISTING VALVE BOX FOR THE WATER UTILITY INSPECTOR TO DETERMINE CONDITION OF EXISTING BOX. INSPECTOR SHALL DIRECT CONTRACTOR TO ADJUST EXISTING VALVE BOX FLUSH TO GRADE AS SHOWN ABOVE, OR REPLACE THE TOP SECTION OF VALVE BOX AS SHOWN IN DETAIL W-620 OR DIRECT CONTRACTOR TO REMOVE AND REPLACE ENTIRE EXISTING VALVE BOX WITH NEW AS PER W-620.
- 2 INSTALL 2-FT DIAMETER CONCRETE COLLAR AROUND VALVE BOX, CONCRETE SHALL BE CLASS 520-A-2500 WITH A MAXIMUM 3" SLUMP.
- 3 3" ASPHALT CAP SHALL TO MATCH EXISTING AS APPROVED BY THE CITY ENGINEER.
- 4 TRENCH REPLACEMENT SHALL BE IN ACCORDANCE WITH SECTION 3-08 AND STANDARD W-647.

REVISED	
DATE	12/07/17
	03/19/19
	06/22/23

CITY OF WHITTIER- WATER DIVISION

VALVE CAN ADJUSTING

APPROVED:  WATER MANAGER

 DIRECTOR OF PUBLIC WORKS

DRAWN: HG
DESIGN: KAC
STD. NO
W-621
SHEET <u>1</u> OF <u>2</u>

LIST OF MATERIAL

ITEM	DESCRIPTION
1	BROOKS 3-RT, EISEL ENTERPRISES NO. 10, TAYLOR MARK V OR (OR APPROVED EQUAL) VALVE BOX LID MARKED WATER
2	CONCRETE SHALL BE CLASS 520-A-2500 WITH A MAXIMUM SLUMP OF 3".

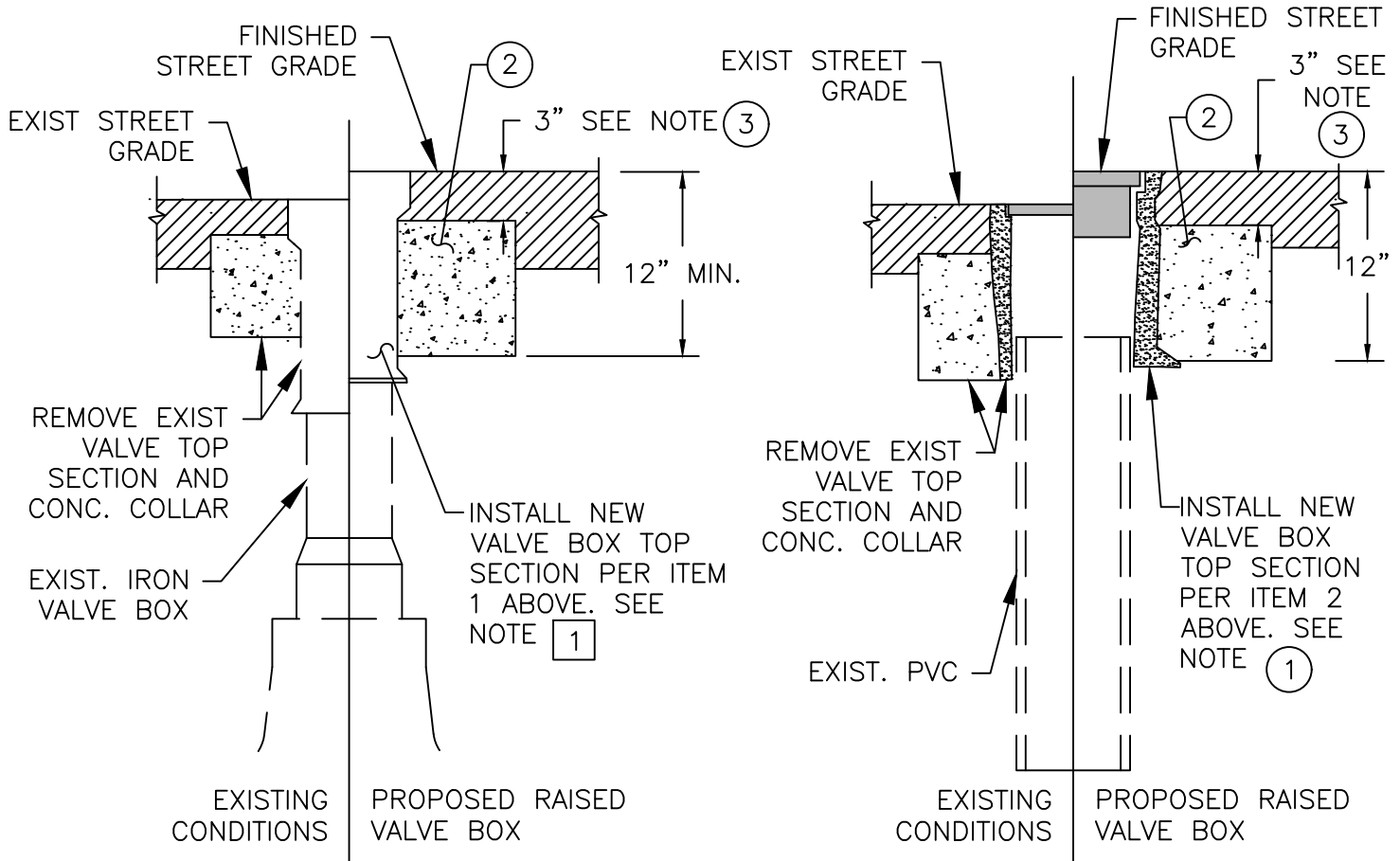

CASE 2

CASE 3

- NOTES:**
- 1 CONTRACTOR TO EXPOSE THE EXISTING VALVE BOX FOR THE WATER UTILITY INSPECTOR TO DETERMINE CONDITION OF EXISTING BOX. INSPECTOR SHALL DIRECT CONTRACTOR TO ADJUST EXISTING VALVE BOX FLUSH TO GRADE AS SHOWN ABOVE, OR REPLACE THE TOP SECTION OF VALVE BOX AS SHOWN IN DETAIL W-620 OR DIRECT CONTRACTOR TO REMOVE AND REPLACE ENTIRE EXISTING VALVE BOX WITH NEW AS PER W-620.
 - 2 INSTALL 2-FT DIAMETER CONCRETE COLLAR AROUND VALVE BOX, CONCRETE SHALL BE CLASS 520-A-2500 WITH A MAXIMUM 3" SLUMP.
 - 3 3" ASPHALT CAP SHALL TO MATCH EXISTING AS APPROVED BY THE CITY ENGINEER.
 - 4 TRENCH REPLACEMENT SHALL BE IN ACCORDANCE WITH SECTION 3-08 AND STANDARD W-647.

REVISED DATE	12/07/17
	03/19/19
	06/22/23

CITY OF WHITTIER- WATER DIVISION

VALVE CAN ADJUSTING

APPROVED:

[Signature]
WATER MANAGER

[Signature]
DIRECTOR OF PUBLIC WORKS

DRAWN: HG
DESIGN: KAC

STD. NO
W-621

SHEET 2 OF 2

METER BOX

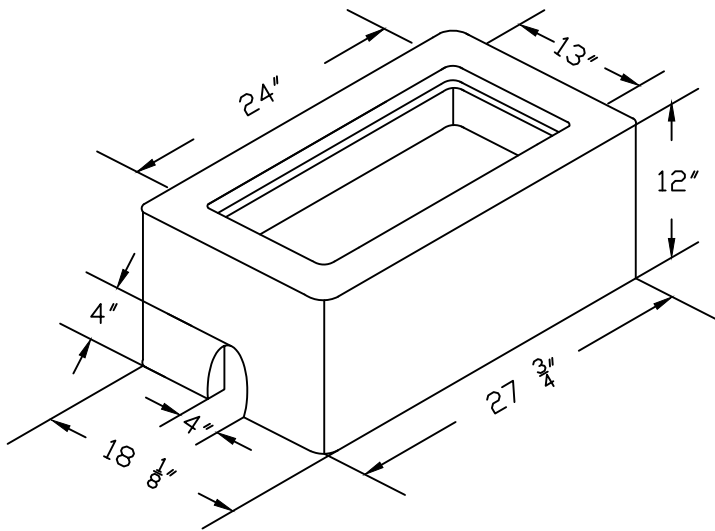

METER BOX
CONCRETE BOX

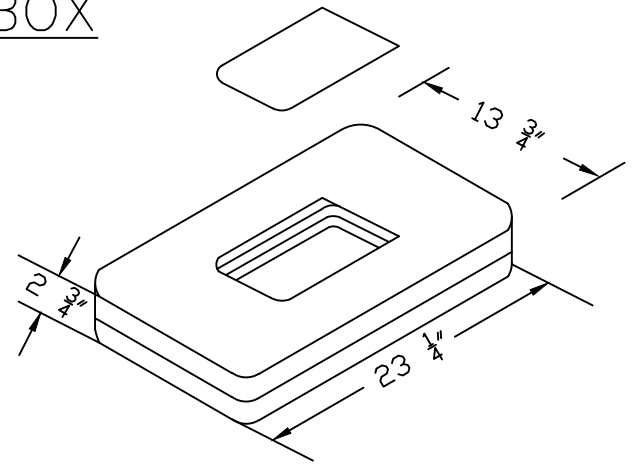

CONCRETE COVER AND CAST
DROP IN LID

1" METER BOX

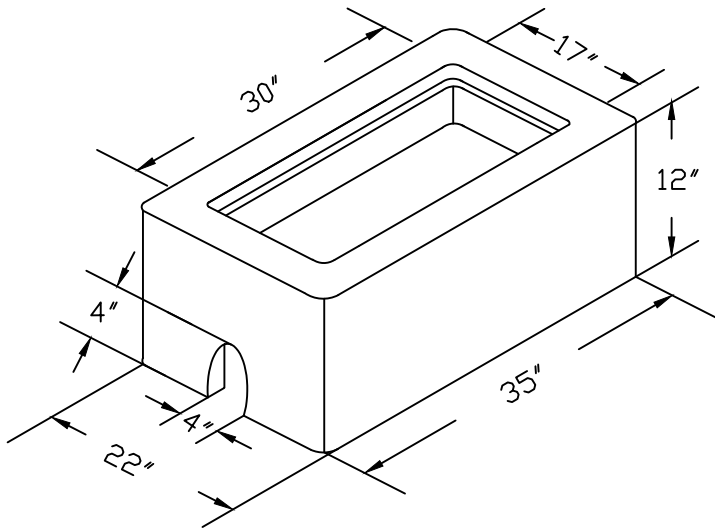

METER BOX
CONCRETE BOX

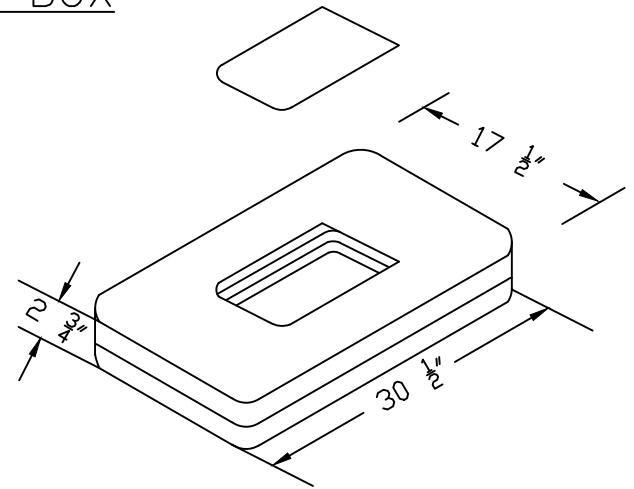

CONCRETE COVER AND CAST
DROP IN LID

2" METER BOX

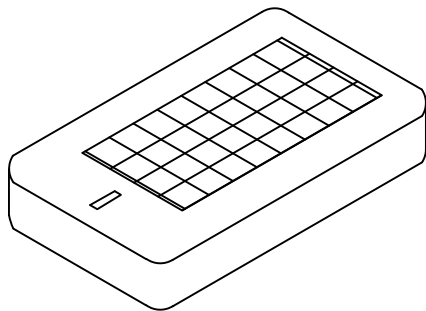

TRAFFIC COVER

METER SIZE	ARMORCAST	
	BODY	LID
3/4"	A6001946PCX12	A6001866DQ & A6000487
1"	A6001946PCX12	A6001866DQ & A6000487
1 1/2"	A6001640PCX12	A6001643DZ & A6000482
2"	A6001640PCX12	A6001643DZ & A6000482

REVISED	
DATE	12/07/17
	02/15/18
	03/19/19
	06/22/23

CITY OF WHITTIER- WATER DIVISION

WATER METER BOX 3/4" THROUGH 2"

APPROVED:



WATER MANAGER

DIRECTOR OF PUBLIC WORKS

DRAWN: HG
DESIGN: KAC

STD. NO
W-625

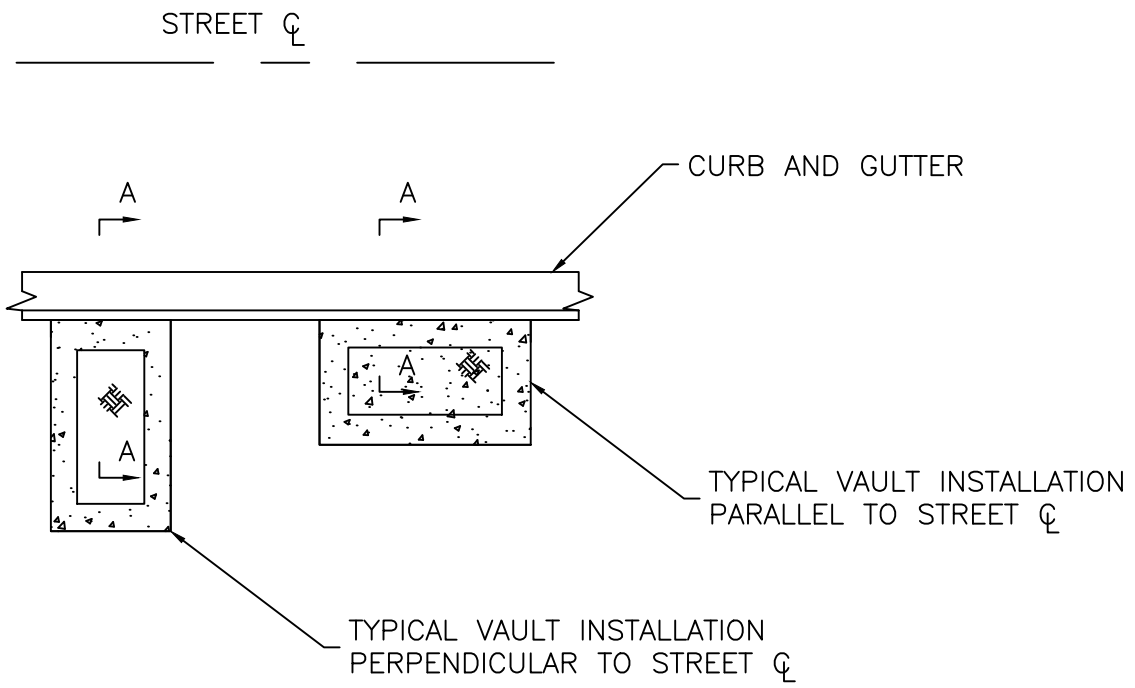
SHEET 1 OF 1



PLAN

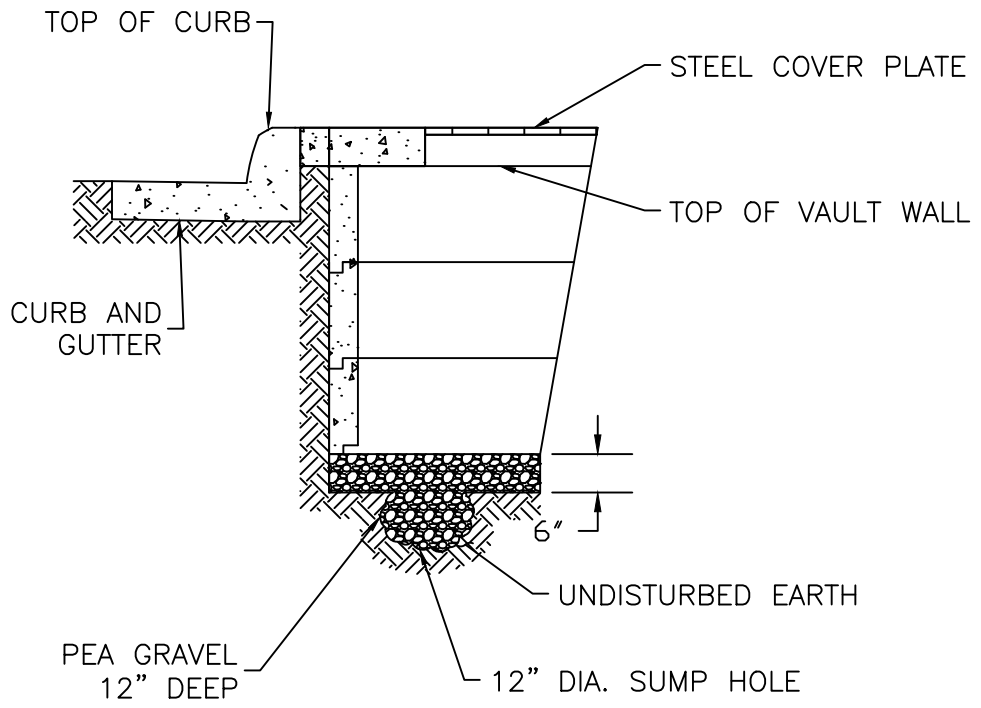

SECTION A-A

NOTES:

1. VAULT SHALL BE A BROOKS PRODUCTS #700 SERIES SECTIONAL VAULT OR APPROVED EQUAL. SIZE TO BE DETERMINED.

REVISED
DATE <u>06/22/23</u>

CITY OF WHITTIER- WATER DIVISION

DRAWN: HG
DESIGN: KAC

STANDARD VAULT INSTALLATION

STD. NO
W-626
SHEET 1 OF 1

APPROVED: 
WATER MANAGER

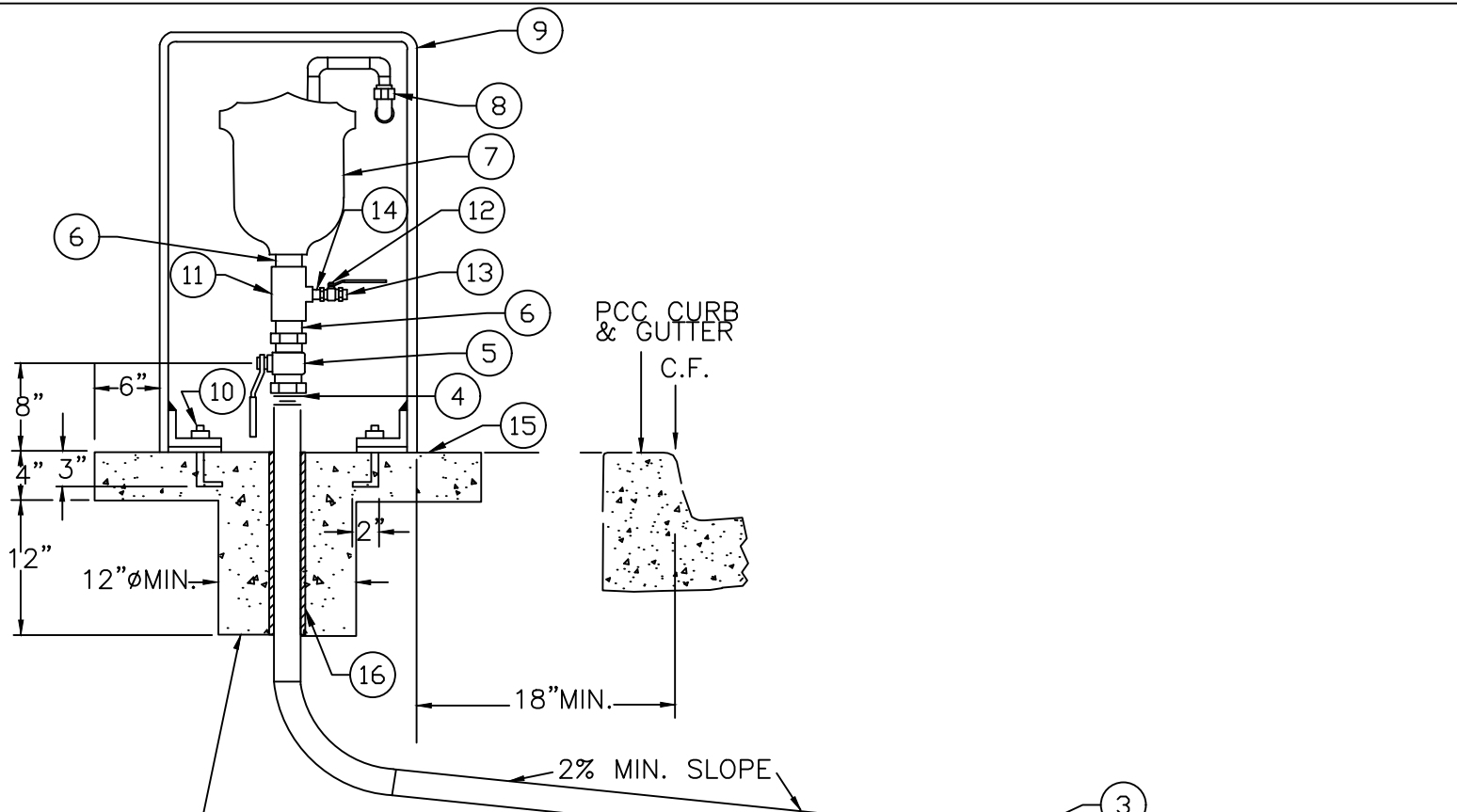

DIRECTOR OF PUBLIC WORKS



PCC PADS & SUPPORT—USE CL. B CONCRETE

PROFILE

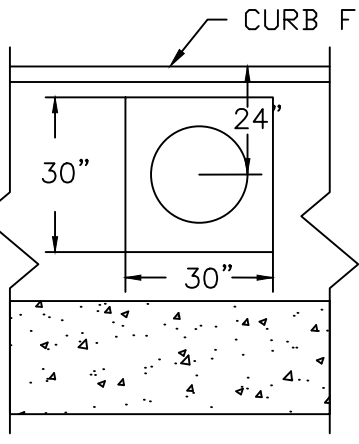
NOTE:
USE CASE 1 IF NO SIDEWALK EXISTS



CASE 1

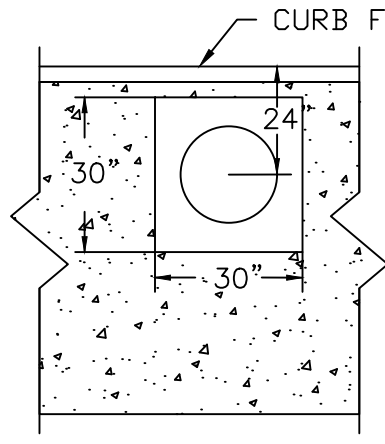

CASE 2

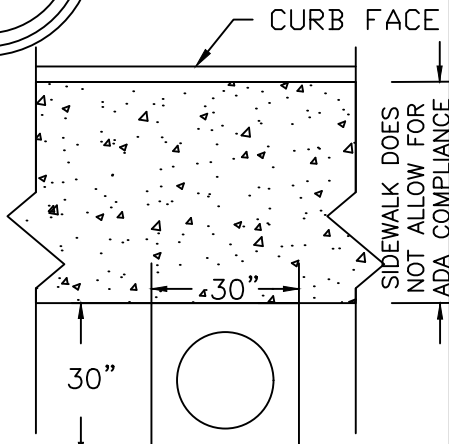

CASE 3

REVISED	
DATE	12/07/17
	02/15/18
	06/22/23

CITY OF WHITTIER- WATER DIVISION

DRAWN: HG
DESIGN: KAC

AUTOMATIC AIR VAC RELEASE ASSEMBLY

STD. NO
W-630

APPROVED: 
WATER MANAGER

DIRECTOR OF PUBLIC WORKS

SHEET 1 OF 2

LIST OF MATERIAL

ITEM	DESCRIPTION
1	1" x MAINSIZE BRONZE DOUBLE STRAP SADDLE MUELLER H-16100 SERIES
2	1" CORPORATION STOP, COMPRESSION, C.T.S., MUELLER H-15028
3	1" COPPER TUBING, TYPE K, SOFT DRAWN
4	1" MALE I.P. THREAD X COMPRESSION
5	1" BRONZE BALL VALVE B-20200N W/ HANDLE
6	1" BRASS NIPPLE
7	1" AIR-RELEASE/AIR-VACUUM/COMBINATION-AIR VALVE (SEE SECTION 2-05)
8	1" OR 2" SCH 80 PVC WITH STAINLESS STEEL SCREEN
9	*POLYETHYLENE ENCLOSURE BY PIPELINE PRODUCTS #VCAS-1830-GM
10	1/2"x5" L STEEL ANCHOR BOLT W/ STAINLESS WASHERS, ELECTRODEPOSITED, ZINC COAT, 3 EA.
11	1"x3/8" BRASS TEE (SEE NOTE 8 BELOW)
12	3/8" BRONZE BALL VALVE (SEE NOTE 8 BELOW)
13	3/8" BRASS PLUG (SEE NOTE 8 BELOW)
14	3/8" BRASS CLOSE NIPPLE (SEE NOTE 8 BELOW)
15	CONCRETE PAD, CLASS 520-C-2500
16	1" THICK CONSTRUCTION FELT OR 10 MIL PE WRAP AROUND PIPE

NOTES:

1. ETCH AND PAINT EXTERIOR SURFACE PER SECTION 2-13 OF SPECIFICATIONS.
2. FOR ALL CASES, THE LOCATION OF ASSEMBLY SHALL MEET ADA REQUIREMENT THAT A MINIMUM 48" CLEARANCE BE MAINTAINED FROM ANY OBSTRUCTION IN THE WALK.
3. ASSEMBLY SHALL BE LOCATED A MINIMUM 5- FEET FROM BCR, ECR OR DRIVEWAY APPROACH.
4. FOR ROLLED CURBS OR NO CURBS, THE DISTANCE FROM THE EDGE OF PAVEMENT TO THE ASSEMBLY SHALL BE AS DIRECTED BY THE ENGINEER.
5. VALVES WITH DRAIN PLUG AT THE BOTTOM OF THE VALVE REQUIRE A 3/8" BRONZE BALL VALVE, 3/8" BRASS PLUG, AND ADDITIONAL BRASS FITTINGS AS REQUIRED FOR PROPER INSTALLATION. PROVIDE SUBMITTAL TO UTILITY FOR REVIEW AND APPROVAL.

REVISED DATE	12/07/17
	02/15/18
	03/19/19
	06/22/23

CITY OF WHITTIER- WATER DIVISION

AUTOMATIC AIR VAC RELEASE ASSEMBLY

APPROVED:  WATER MANAGER

 DIRECTOR OF PUBLIC WORKS

DRAWN: HG DESIGN: KAC
STD. NO W-630
SHEET <u>2</u> OF <u>2</u>

NOTES:

1. ANCHOR BLOCKS SHALL BE 5-C-2000 (2000 P.S.I. @ 28 DAY)
2. CONCRETE SHALL BE POURED AGAINST UNDISTURBED SOIL.
3. CONCRETE SHALL HAVE 3" MINIMUM CLEARANCE AROUND ALL JOINTS.
4. BEARING SURFACE REQUIREMENTS SHALL BE PER STD. DRAWING OR CONSTRUCTION DRAWINGS.

ANGLE "A" SHALL
BE 30° TO 45°

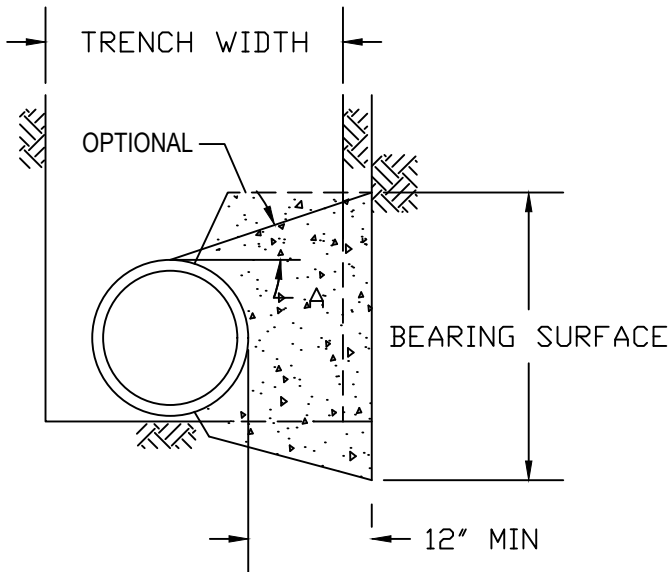

TYPICAL SECTION

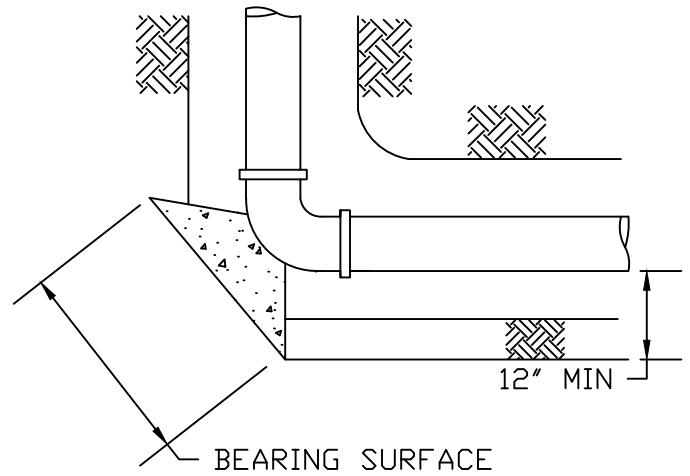

BEND

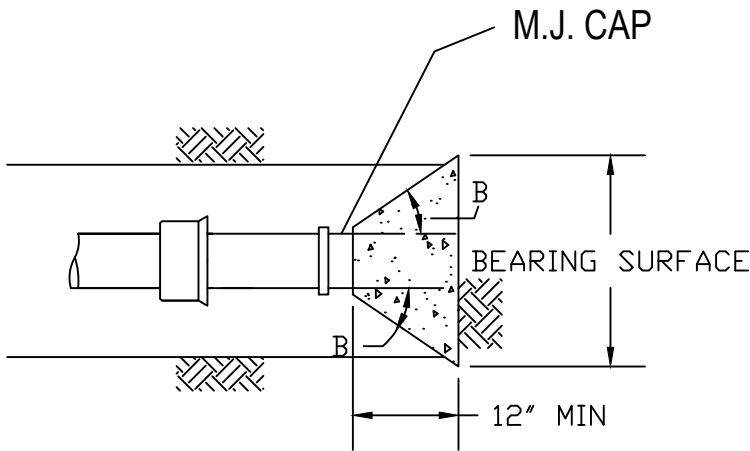

ANGLE "B" SHALL
BE 30° TO 45°

DEAD END

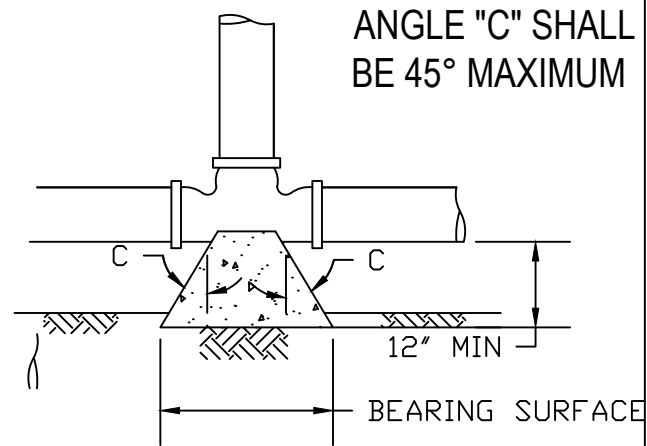

ANGLE "C" SHALL
BE 45° MAXIMUM

TEE AND TAPPING SLEEVES

TYPICAL THRUST BLOCK DETAILS
4" TO 12" DIA. FITTINGS

REVISED
DATE 06/22/23

CITY OF WHITTIER- WATER DIVISION

DRAWN: HG
DESIGN: KAC

TYPICAL THRUST BLOCK DETAILS
4" TO 12" DIA. FITTINGS

STD. NO
W-635

APPROVED:

WATER MANAGER

DIRECTOR OF PUBLIC WORKS

SHEET 1 OF 2

DEAD END:

	STATIC WATER PRESSURE- P.S.I.									
PIPE DIA.	60	70	80	90	100	110	120	130	140	150
4" & 6"	2.0	2.0	2.0	2.0	3.0	3.0	3.0	3.0	3.0	3.0
8"	2.5	2.5	3.0	3.5	4.0	4.0	4.5	5.0	5.5	5.5
10"	3.5	4.0	5.0	5.5	6.0	6.5	7.0	7.5	8.5	9.0
12"	5.0	6.0	7.0	8.0	8.5	9.5	10.0	11.0	12.0	13.0

TEE OUTLET & TAPPING SLEEVE:

	STATIC WATER PRESSURE- P.S.I.									
PIPE DIA.	60	70	80	90	100	110	120	130	140	150
4" & 6"	2.0	2.0	2.0	2.0	3.0	3.0	3.0	3.0	3.0	3.0
8"	2.5	2.5	3.0	3.0	4.0	4.0	4.5	5.0	5.5	5.5
10"	3.5	4.0	5.0	5.5	6.0	6.5	7.0	7.5	8.5	9.0
12"	5.0	6.0	7.0	8.0	8.5	9.5	10.0	11.0	12.0	13.0

BENDS:

		STATIC WATER PRESSURE- P.S.I.												STATIC WATER PRESSURE- P.S.I.									
PIPE DIA.	BEND	60	70	80	90	100	110	120	130	140	150	PIPE DIA.	BEND	60	70	80	90	100	110	120	130	140	150
4" & 6"	90°	2.0	2.0	2.5	3.0	3.0	3.5	3.5	4.0	4.0	4.5	10"	90°	5.0	6.0	7.0	7.5	8.5	9.0	10.0	11.0	12.0	12.5
	45°	1.0	1.0	2.0	2.0	2.0	2.0	2.0	2.5	2.5	2.5		45°	3.0	3.0	3.5	4.0	4.5	5.0	5.5	6.0	6.5	7.0
	$\frac{22\frac{1}{2}^\circ}{2}$	1.0	1.0	1.0	1.0	1.0	1.0	1.0	1.0	2.0	2.0		$\frac{22\frac{1}{2}^\circ}{2}$	2.0	2.0	2.0	2.0	2.5	2.5	3.0	3.0	3.5	3.5
	$\frac{11\frac{1}{4}^\circ}{4}$	1.0	1.0	1.0	1.0	1.0	1.0	1.0	1.0	1.0	1.0		$\frac{11\frac{1}{4}^\circ}{4}$	1.0	1.0	1.0	1.0	1.0	2.0	2.0	2.0	2.0	2.0
8"	90°	3.0	4.0	4.5	5.0	5.5	6.0	6.5	7.0	7.5	8.0	12"	90°	7.0	8.5	9.5	11.0	12.0	13.0	14.5	15.5	17.0	18.0
	45°	2.0	2.0	2.5	2.5	3.0	3.0	3.5	4.0	4.0	4.5		45°	4.0	4.5	5.0	6.0	6.5	7.0	8.0	8.5	9.0	10.5
	$\frac{22\frac{1}{2}^\circ}{2}$	1.0	1.0	1.0	2.0	2.0	2.0	2.0	2.0	2.0	2.5		$\frac{22\frac{1}{2}^\circ}{2}$	2.0	2.5	3.0	3.0	3.5	3.5	4.0	4.5	5.0	5.0
	$\frac{11\frac{1}{4}^\circ}{4}$	1.0	1.0	1.0	1.0	1.0	1.0	1.0	1.0	1.0	1.0		$\frac{11\frac{1}{4}^\circ}{4}$	1.0	1.0	2.0	2.0	2.0	2.0	2.0	2.0	2.0	2.5

REVISED
DATE 06/22/23

CITY OF WHITTIER- WATER DIVISION

DRAWN: HG
DESIGN: KAC

TYPICAL THRUST BLOCK DETAILS

4" TO 12" DIA. FITTINGS

STD. NO

W-635

APPROVED:

WATER MANAGER

DIRECTOR OF PUBLIC WORKS

SHEET 2 OF 2

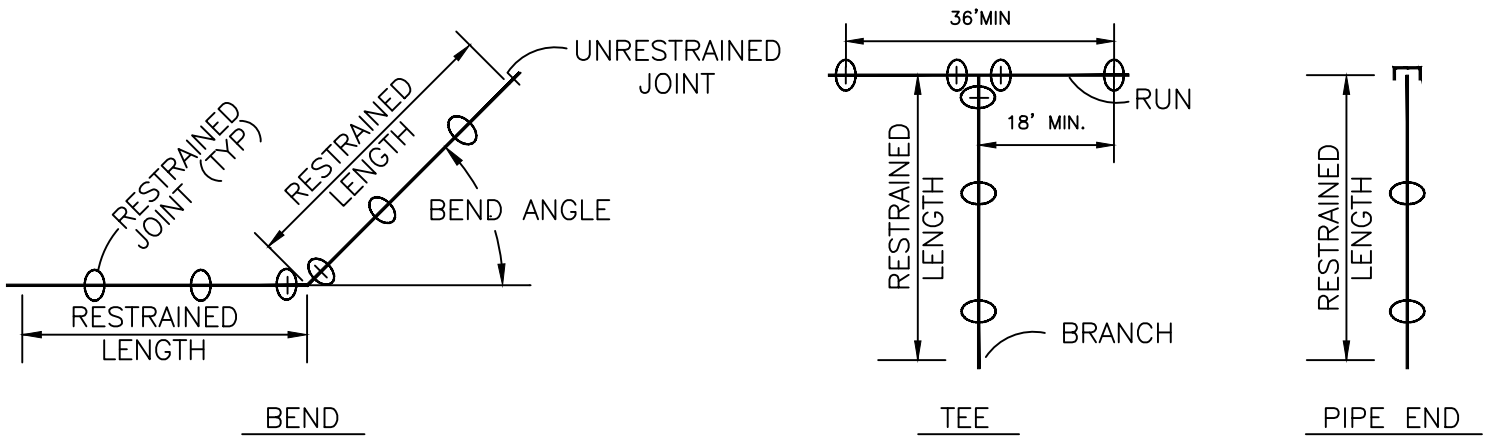

PIPE SIZE	11 1/4" BEND	22 1/2" BEND	45° BEND	90° BEND	TEE*	PIPE END
4"	X	X	X	X	X	50'
6"	X	X	X	X	X	70'
8"	X	X	X	43'	51'	90'
10"	X	X	X	52'	69'	109'
12"	X	X	X	60'	86'	127'
16"	X	X	X	75'	120'	161'

X=2 FIRST TWO FULL PIPE JOINTS UPSTREAM AND DOWNSTREAM

NOTES:

1. JOINT RESTRAINTS SHALL BE REQUIRED AT THE FIRST TWO FULL PIPE JOINTS UPSTREAM AND DOWNSTREAM OF BENDS, TEES, VALVES, PIPE ENDS, AND FIRE HYDRANTS
2. THIS TABLE IS BASED ON THE ASSUMPTION THAT THE TRENCH IS BACKFILLED TO A MINIMUM DEPTH OF 2.5 FEET WITH A SILTY SAND WHICH HAS BEEN LIGHTLY COMPACTED.
3. FOR PIPE DIAMETERS LARGER THAN 16", OR FOR CONDITIONS OTHER THAN THOSE DESCRIBED ABOVE, PLEASE REFER TO DUCTILE IRON PIPE RESEARCH ASSOCIATION (DIPRA) GUIDELINES FOR CALCULATING RESTRAINED LENGTH. CALCULATIONS MUST BE SUBMITTED FOR APPROVAL.
4. RESTRAINED LENGTH ON TEES ASSUMES THE SAME SIZE BRANCH AND RUN. TEES WHICH HAVE BRANCH DIAMETERS LESS THAN THE DIAMETER OF THE RUN MAY REQUIRE A SHORTER RESTRAINED LENGTH. CALCULATIONS MUST BE SUBMITTED JUSTIFYING A SHORTER RESTRAINED LENGTH.
5. ALL PIPELINES LARGER THAN 16" DIAMETER REQUIRE RESTRAINED LENGTH CALCULATIONS INCLUDING SOILS REPORT.
6. INTERNAL OR EXTERNAL RESTRAINTS SHALL BE USED IN LIEU OF THRUST BLOCKS UNLESS OTHERWISE NOTED. THE USE OF EXTERNAL RESTRAINTS SHALL REQUIRE PRE-APPROVAL FROM THE CITY ENGINEER.
7. CALCULATIONS SHALL BE REQUIRED AT THE REQUEST OF THE CITY ENGINEER IF NECESSARY. THE CITY OF WHITTIER USES WWW.EBAA.COM/CALCULATOR TO CALCULATE RESTRAINT LENGTHS.

REVISED DATE 12/07/17
06/22/23

CITY OF WHITTIER- WATER DIVISION

RESTRAINED JOINT DETAIL

APPROVED: 
WATER MANAGER



DIRECTOR OF PUBLIC WORKS

DRAWN: HG
DESIGN: KAC

STD. NO
W-636

SHEET 1 OF 1

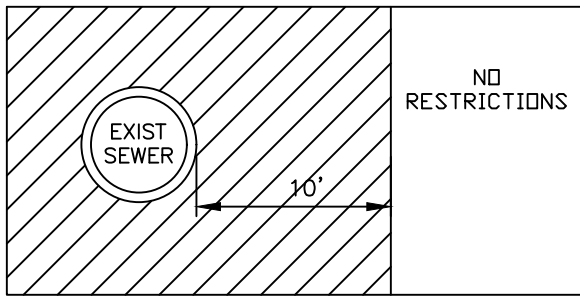
CASE A
FINISHED SURFACE



PARALLEL CONSTRUCTION REQUIREMENTS NEAR SEWERS

NOTES:

1. NEW WATER MAINS SHALL NOT BE INSTALLED IN THE SAME TRENCH AND SHALL BE AT LEAST 10 FEET HORIZONTALLY FROM AND 1 FOOT VERTICALLY ABOVE ANY PARALLEL PIPELINE CONVEYING:
 - 1.A. UNTREATED SEWAGE
 - 1.B. PRIMARY OR SECONDARY TREATED SEWAGE
 - 1.C. DISINFECTED SECONDARY RECYCLED WATER
 - 1.D. HAZARDOUS FLUIDS SUCH AS FUELS, INDUSTRIAL WASTES AND WASTEWATER
2. USE PROFESSIONAL JUDGEMENT TO PROPOSE CONSTRUCTION THAT IS PROTECTIVE OF PUBLIC HEALTH.

CASE B
FINISHED SURFACE

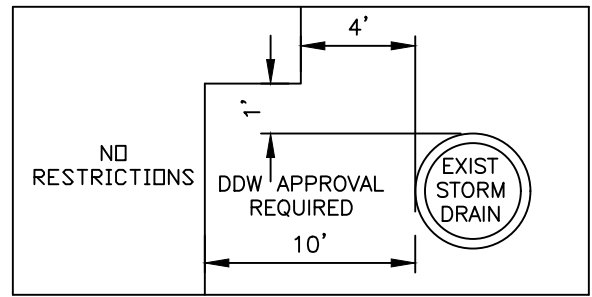

PARALLEL CONSTRUCTION REQUIREMENTS NEAR STORM DRAINS

NOTES:

1. NEW WATER MAINS SHALL NOT BE INSTALLED IN THE SAME TRENCH AND SHALL BE AT LEAST 4 FEET HORIZONTALLY FROM AND 1 FOOT VERTICALLY ABOVE ANY PARALLEL PIPELINE CONVEYING:
 - 1.A. STORM DRAINAGE
 - 1.B. DISINFECTED TERTIARY RECYCLED WATER
2. USE PROFESSIONAL JUDGEMENT TO PROPOSE CONSTRUCTION THAT IS PROTECTIVE OF PUBLIC HEALTH.
3. THE VERTICAL SEPARATION IN CASE B IS REQUIRED WHEN THE HORIZONTAL SEPARATION IS LESS THAN 10 FEET.

CASE C
FINISHED SURFACE

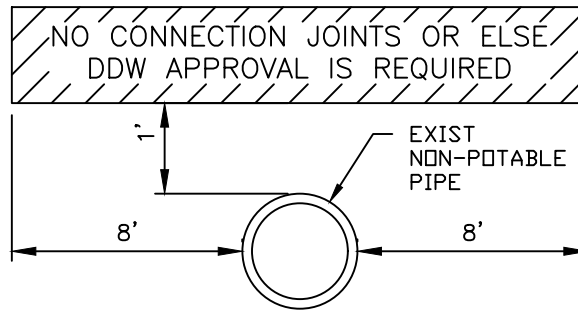

CROSSING CONSTRUCTION REQUIREMENTS NEAR NON-POTABLE PIPELINES

NOTES:

1. NEW WATER MAINS CROSSING AN EXISTING PIPELINE CARRYING NON-POTABLE WATER FLUIDS (AS LISTED IN CASE A OR CASE B) SHALL BE CONSTRUCTED NO LESS THAN 45-DEGREES TO AND AT LEAST 1 FOOT ABOVE THE EXISTING PIPELINE. A DDW WAIVER IS NOT REQUIRED IF THE ANGLE OF THE CROSSING IS GREATER THAN 45 DEGREES AND THE WATER MAIN IS AT LEAST 1 FOOT ABOVE THE PIPE BEING CROSSED.
2. NO CONNECTION JOINTS SHALL BE MADE IN THE WATERLINE WITHIN 8 FEET HORIZONTAL MEASURED ON EITHER SIDE OF THE NON-POTABLE FLUID PIPELINE (WALL TO WALL MEASUREMENT).
3. USE PROFESSIONAL JUDGEMENT TO PROPOSE CONSTRUCTION THAT IS PROTECTIVE OF PUBLIC HEALTH.

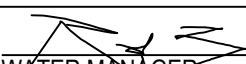
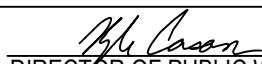
REVISED DATE <u>06/22/23</u> _____ _____ _____ _____	CITY OF WHITTIER- WATER DIVISION SEWER AND WATER SEPERATION REQUIREMENT	DRAWN: JG DESIGN: KAC STD. NO W-640 SHEET <u>1</u> OF <u>3</u>
APPROVED: _____ <div style="display: flex; justify-content: space-around;"> <div style="text-align: center;">  WATER MANAGER </div> <div style="text-align: center;">  DIRECTOR OF PUBLIC WORKS </div> </div>		

GENERAL NOTES:

1. APPLICATION OF THIS STANDARD DRAWING MUST COMPLY WITH SECTION 64572, TITLE 22, CALIFORNIA CODE OF REGULATIONS, LATEST VERSION.
2. IF THE CONDITION OF THE EXISTING SEWER CANNOT BE READILY DETERMINED, THE ALTERNATIVE CONSTRUCTION REQUIREMENTS FOR WATER MAINS DESCRIBED BELOW SHALL APPLY DEPENDING ON IF THE CROSSING IS PERPENDICULAR OR PARALLEL.
3. A "SEWER LINE" IS DEFINED AS A PIPELINE CONVEYING NON-POTABLE WATER OR HAZARDOUS LIQUIDS INCLUDING BUT NOT LIMITED TO STORM DRAINAGE, RECYCLED WATER, SEWAGE, AND FUELS.
4. ALL EXCEPTIONS TO THESE MINIMUM SEPARATION STANDARDS MUST BE REVIEWED BY THE DIVISION OF DRINKING WATER (DDW) AND A WRITTEN WAIVER OBTAINED PRIOR TO CONSTRUCTION OF THE CROSSING.

I. SEPARATION STANDARDS PER DIVISION OF DRINKING WATER REQUIREMENTS (DDW)

A. THE MINIMUM SEPARATION REQUIREMENTS BETWEEN WATER MAINS AND NON-POTABLE PIPELINES AS CONTAINED IN SECTION 64572, TITLE 22, CALIFORNIA CODE OF REGULATIONS

I. PARALLEL CONSTRUCTION REQUIREMENTS:

- A. SEWER LINES: WATER MAIN SHALL BE AT LEAST 10 FEET CLEAR HORIZONTAL DISTANCE FROM SEWER LINES 1 FOOT CLEAR VERTICAL DISTANCE ABOVE SEWER LINES.
- B. STORM DRAIN OR RECYCLED WATER PIPELINES: WATER MAINS SHALL BE AT LEAST 4 FEET CLEAR HORIZONTAL AND 1 FOOT CLEAR VERTICAL DISTANCE ABOVE STORM DRAIN OR RECYCLED WATER PIPELINES.

II. CROSSING CONSTRUCTION REQUIREMENTS: WHEN PIPELINES MUST CROSS, POTABLE WATER MAINS SHALL BE AT LEAST 1 FOOT CLEAR ABOVE NON-POTABLE PIPELINES AND AT NO LESS THAN 45-DEGREES CROSSING ANGLE.

III. SEPARATION DISTANCE AS SPECIFIED SHALL BE MEASURED FROM THE NEAREST OUTSIDE EDGE OF EACH PIPELINE; I.E. THE CLEAR DISTANCE.

IV. WATER MAINS AND SEWER LINES MUST NOT BE INSTALLED IN THE SAME COMMON TRENCH.

V. NEW WATER MAINS SHALL NOT BE INSTALLED WITHIN 100 HORIZONTAL FEET OF THE NEAREST EDGE OF ANY SANITARY LANDFILL, WASTEWATER DISPOSAL POND OR HAZARDOUS WASTE DISPOSAL SITE OR WITHIN 25 HORIZONTAL FEET OF THE NEAREST EDGE OF ANY CESSPOOL, SEPTIC TANK, SEWAGE LEACH FIELD, SEEPAGE PIT, UNDERGROUND HAZARDOUS MATERIAL STORAGE TANK OR GROUNDWATER RECHARGE PROJECT SITE WITHOUT WRITTEN APPROVAL OF THE DEPARTMENT OF DRINKING WATER.

B. EXCEPTIONS TO BASIC SEPARATION STANDARDS

- I. LOCAL CONDITIONS MAY CREATE A SITUATION WHERE THERE IS NO ALTERNATIVE BUT TO INSTALL WATER MAINS AT A DISTANCE LESS THAN THAT REQUIRED BY THE BASIC SEPARATION STANDARDS ABOVE, IN SUCH CASES ALTERNATIVE CONSTRUCTION CRITERIA AS SHOWN BELOW SHOULD BE FOLLOWED.
- II. SEWER MAINS OF 24 INCHES IN DIAMETER OR LARGER MAY CREATE SPECIAL HAZARDS BECAUSE OF THE VICINITY OF SEWER MAINS 24 INCHES IN DIAMETER OR LARGER MUST BE REVIEWED ON A CASE-BY-CASE BASIS BY DDW TO DETERMINE IF THE SEPARATION AND PROTECTION MEASURES ARE ADEQUATE.

REVISED DATE <u>06/22/23</u> _____ _____ _____ _____ _____	CITY OF WHITTIER- WATER DIVISION SEWER AND WATER SEPERATION REQUIREMENT	DRAWN: JG DESIGN: KAC STD. NO W-640 SHEET <u>2</u> OF <u>3</u>
APPROVED:  WATER MANAGER		 DIRECTOR OF PUBLIC WORKS

GENERAL NOTES CONTINUED:

II. CONSTRUCTION OF WATER LINES PARALLEL TO SEWER AND STORM DRAIN LINES

A. SEE CASE A AND CASE B

B. NEW WATER MAINS IN THIS ZONE SHALL BE CONSTRUCTED OF SPECIAL PIPE MATERIALS (SEE SECTION VI). JOINTS SHALL RESTRAINED.

III. CONSTRUCTION OF WATER LINES CROSSING SEWER AND STORM DRAIN LINES

A. SEE CASE C

B. THE NEW WATER MAIN IN THIS ZONE SHALL HAVE NO JOINTS IN THIS AREA OVER THE EXISTING NON-POTABLE PIPE UNLESS THEY ARE RESTRAINED AND SHALL BE CONSTRUCTED OF SPECIAL PIPE MATERIAL.

IV. CROSSING OF A SEWER FORCE MAIN

A. IN ADDITION TO OTHER SEWER REQUIREMENTS, WHEN A NEW WATER MAIN CROSSES OVER AN EXISITING SEWER FORCE MAIN THE WATER MAIN SHALL BE CONSTRUCTED OF PIPE MATERIALS WITH A MINIMUM RATED WORKING PRESSURE OF 200 PSI.

B. NO WATER MAIN SHALL CROSS UNDER A SEWER FORCE MAIN.

V. CROSSING OF GRAVITY SEWER LATERALS

A. SPECIAL CONSTRUCTION CRITERIA, AS DEFINED ABOVE, SHALL APPLY TO SEWER LATERALS THAT CROSS ABOVE A POTABLE WATER MAIN BUT NOT TO SEWER LATERALS THAT CROSS BELOW A POTABLE WATER MAIN.

VI. DEFINITION OF SPECIAL PIPE MATERIAL

A. DUCTILE IRON PIPE (CLASS 350) WITH BITUMASTIC COATING (AWWA C151), OR

B. WELDED STEEL PIPE, CML & WRAPPED OR CML&C RATED AT 200 PSI OR GREATER, OR

C. PVC WATER PIPE (CLASS 305 DR14) (AWWA C-900) OR EQUIVALENT, OR

D. REINFORCED CONCRETE PRESSURE PIPE, STEEL CYLINDER PIPE, 200 PSI MINIMUM, (AWWA C300, C301 OR C303, LATEST REVISIONS), OR

E. HDPE PIPE WITH FUSION WELDED JOINTS, (DR-18, 200 PSI MINIMUM) (AWWA C906)

REVISED
DATE <u>06/22/23</u>

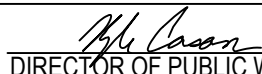
CITY OF WHITTIER- WATER DIVISION	
SEWER AND WATER SEPERATION REQUIREMENT	
APPROVED: 	
WATER MANAGER	DIRECTOR OF PUBLIC WORKS

DRAWN: JG DESIGN: KAC
STD. NO W-640
SHEET <u>3</u> OF <u>3</u>

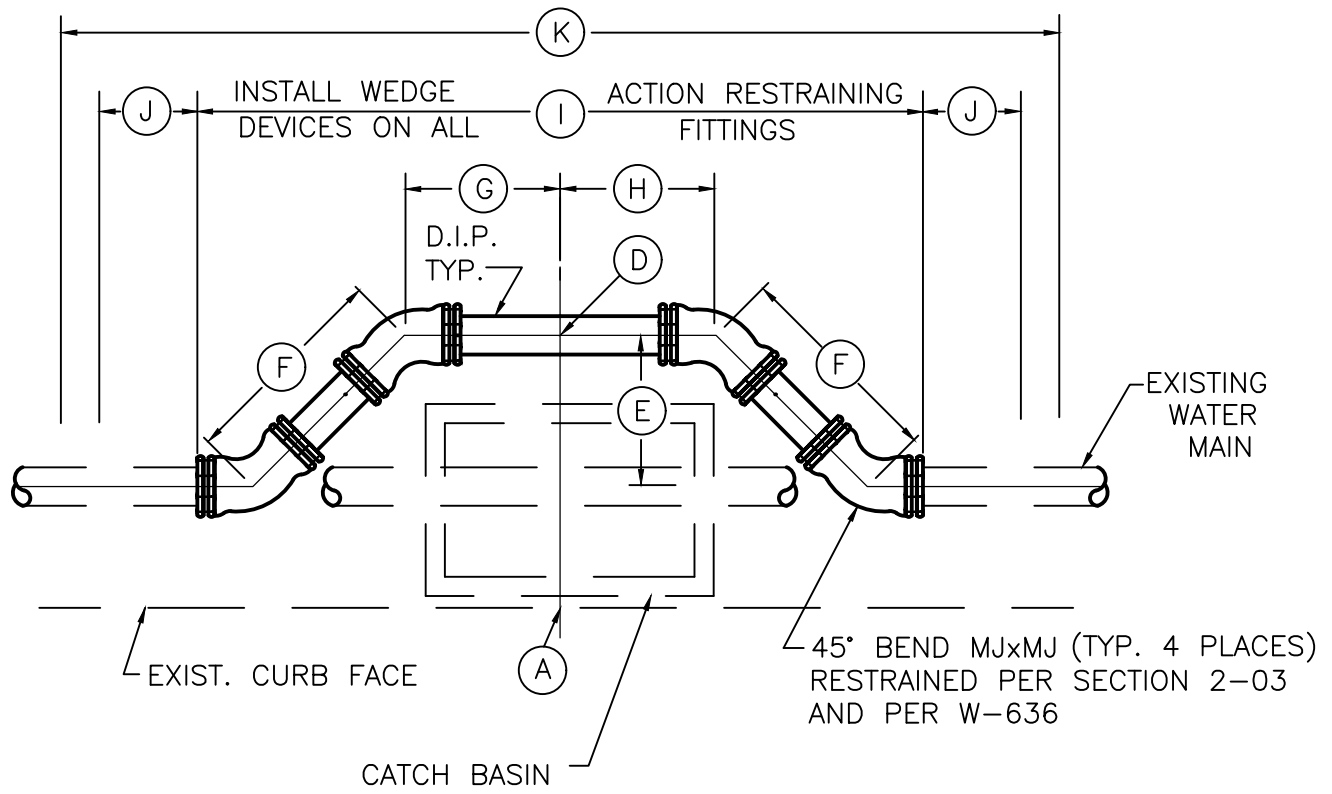



TYPE 1 OFFSET – PLAN

NOTE:
SEE NOTES 9, 10 AND 11 ON SHEET 4.

REVISED
DATE <u>12/07/17</u>
<u>06/22/23</u>

CITY OF WHITTIER- WATER DIVISION

WATER MAIN OFFSET / SIPHON

APPROVED:  WATER MANAGER  DIRECTOR OF PUBLIC WORKS

DRAWN: HG
DESIGN: KAC

STD. NO
W-641
SHEET 1 OF 4

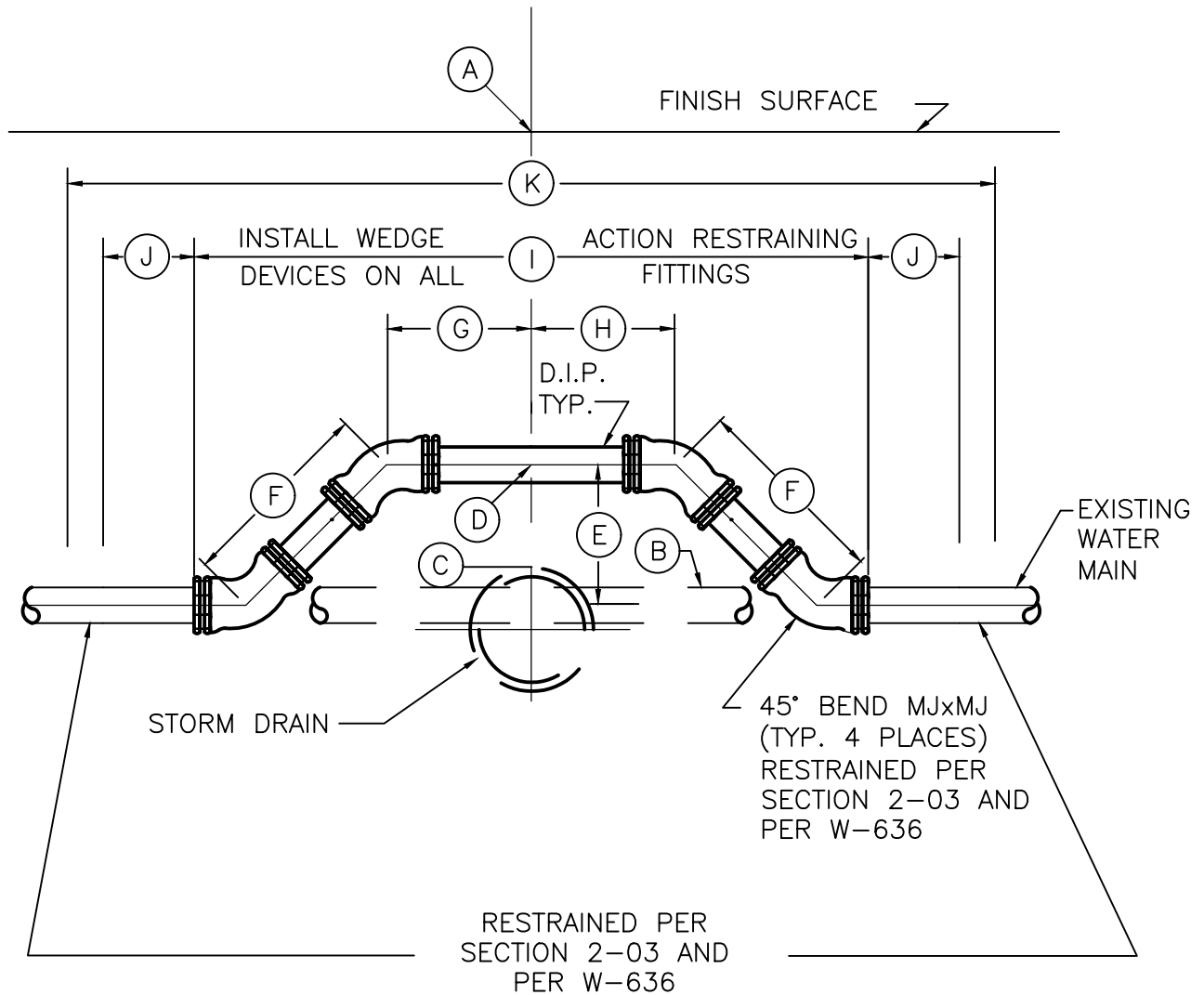

TYPE 2 SIPHON - ELEV.

NOTE:
SEE NOTES 9, 10 AND 11 ON SHEET 4.

REVISED
DATE <u>12/07/17</u>
<u>06/22/23</u>

CITY OF WHITTIER- WATER DIVISION

WATER MAIN OFFSET / SIPHON

APPROVED:

[Signature]
WATER MANAGER

[Signature]
DIRECTOR OF PUBLIC WORKS

DRAWN: HG
DESIGN: KAC

STD. NO
W-641

SHEET 2 OF 4

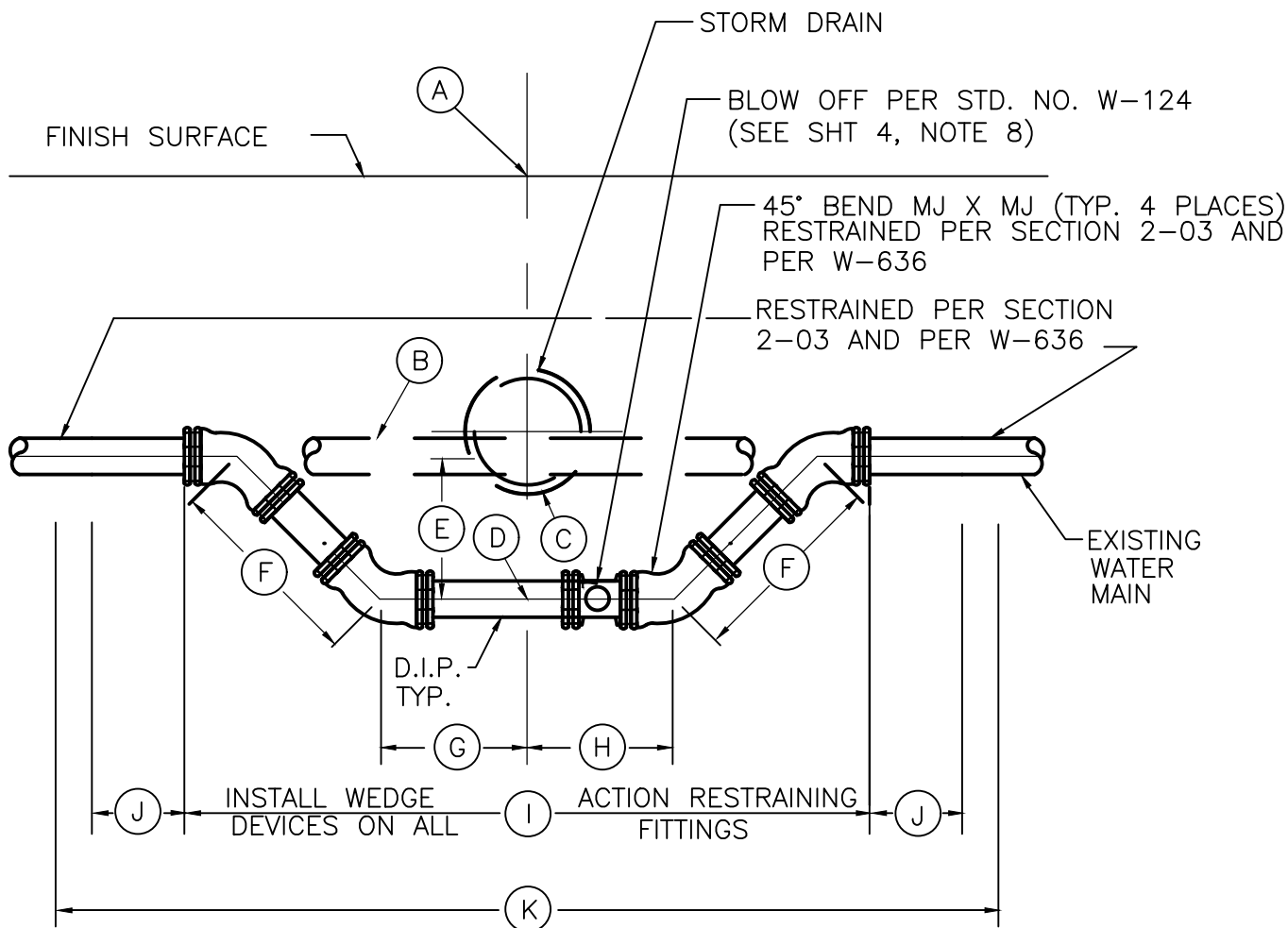

TYPE 3 SIPHON - ELEV.

NOTE:
SEE NOTES 9, 10 AND 11 ON SHEET 4.

REVISED DATE <u>12/07/17</u> <u>06/22/23</u> _____ _____ _____	CITY OF WHITTIER- WATER DIVISION		DRAWN: HG DESIGN: KAC
	WATER MAIN OFFSET / SIPHON		STD. NO W-641
	APPROVED:  WATER MANAGER	 DIRECTOR OF PUBLIC WORKS	SHEET <u>3</u> OF <u>4</u>

DIMENSIONS

Siphon No.	LOCATION/REMARKS	S.D. Station	Prop. S.D. size or Ex. Obstr.	Water Main Size & Type (EX.)	Siphon Type	Exist. Fin. Sur. Elev.	Exist. Top of Wtr. Pipe	Top/BTM Elev. S.D.	Water Siphon Sta.	Water Main Offset	Length Pipe & Fit'g	Length Pipe & Fit'g	Length Pipe & Fit'g	Length Pipe & Fit'g Offset	Length Tie Rod to Anc. Blk.	Total length Offset
						(A)	(B)	(C)	(D)	(E)	(F)	(G)	(H)	(I)	(J)	(K)

NOTES:

1. THIS STANDARD TO BE USED ONLY WHERE APPROVED BY UTILITY. ALL WORK SHALL BE DONE IN ACCORDANCE WITH THE CITY OF WHITTIER WATER UTILITY STANDARD SPECIFICATIONS AND PLANS.
2. THE CONTRACTOR SHALL NOTIFY THE CITY OF WHITTIER WATER DIVISION TWO (2) WEEKS PRIOR TO BEGINING OF CONSTRUCTION TO ARRANGE FOR INSPECTION. PHONE (562) 567-9500.
3. THE CONTRACTOR SHALL VERIFY TYPE, LOCATION AND ELEVATION OF THE EXISTING OBSTRUCTION PRIOR TO CONSTRUCTION OF THE OFFSET / SIPHON.
4. THE CONTRACTOR SHALL COORDINATE W/THE WATER DIVISION FOR NOTIFICATION OF ALL WATER CUSTOMERS A MINIMUM OF THREE (3) WORKING DAYS PRIOR TO SERVICE INTERRUPTION.
5. CONTRACTOR IS NOT PERMITTED TO TURN (OR EXERCISE) WATER VALVES. THE CONTRACTOR SHALL CONTACT THE CITY OF WHITTIER WATER DIVISION AT (562) 567-9500 A MINIMUM OF FIVE (5) WORKING DAYS PRIOR TO REQUIRING VALVE SHUT DOWN AT EACH LOCATION.
6. THE CITY OF WHITTIER WATER DIVISION CANNOT GUARANTEE A COMPLETE SHUT DOWN OF EXISTING MAIN. THE UTILITY WILL ATTEMPT TO SHUT DOWN MAINS AS COMPLETELY AS POSSIBLE; HOWEVER, THE CONTRACTOR SHALL BE RESPONSIBLE FOR DEWATERING AND ISOLATION OF CONSTRUCTION FOR TESTING PURPOSES. THE CITY CONSIDERS APPROXIMATELY 150 GALLONS PER MINUTE TO BE A WORKABLE SHUTDOWN.
7. IF EXISTING MAIN IS A.C.P., CONNECT D.I.P. TO THE EXSTING A.C.P. USING AN APPROVED SLEEVE TYPE COUPLING IN ACCORDANCE WITH THE SPECIFICATION. DO NOT TIE TO A.C.P. WITH RESTRAINING GLANDS. USE THRUST BLOCKS IF NECESSARY.
8. TYPE OF BLOW-OFF ASSEMBLY SHALL BE INSTALLED ONLY IF APPROVED BY THE WATER DIVISION AND SPECIFICALLY CALLED FOR ON THE PROJECT PLANS.
9. PVC WATER MAIN CONSTRUCTION SHALL BE PRE-APPROVED BY UTILITY PER SEE SECT. 2-02. PVC LARGER THAN 12" DIA. IS NOT ALLOWED.
10. PVC PIPE SHALL BE AWWA C900 AS SPECIFIED BY ENGINEER (SEE NOTE 9).
11. MECHANICAL JOINT RESTRAINT PIPE SHALL BE AS PER SPECIFICATION SECTION 2-03 AND DETAIL W-636.

REVISED
DATE <u>12/07/17</u>
<u>06/22/23</u>

<h2 style="margin: 0;">CITY OF WHITTIER- WATER DIVISION</h2> <h3 style="margin: 0;">WATER MAIN OFFSET / SIPHON</h3>
APPROVED:

DRAWN: HG DESIGN: KAC
STD. NO W-641
SHEET <u>4</u> OF <u>4</u>

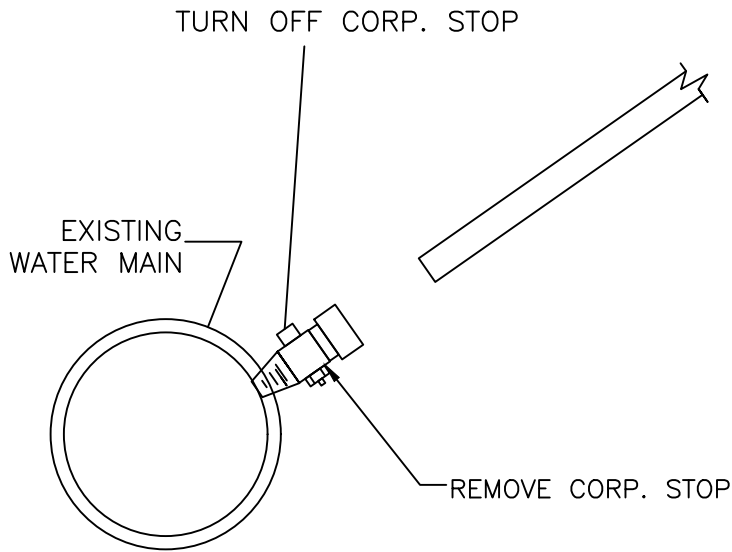

1. CUSTOMER MUST REQUEST TURN-OFF AND WATER METER TO BE REMOVED BY THE CITY 24 HRS. BEFORE WATER SERVICE IS TO BE ABANDONED.
2. PERMIT AND INSPECTION FEE REQUIRED.
3. LOCATION OF CORPORATION STOP TO BE DETERMINED BY CONTRACTOR.
4. WATER METER BOX TO BE REMOVED:
 - A. PARKWAY— FILL HOLE WITH CLEAN DIRT AND GRADE LEVEL.
 - B. SIDEWALK— SAW CUT 12" ON EACH SIDE OF METER BOX AND POUR SIDEWALK TO MEET CITY STANDARD.
5. EXCAVATION AND BACKFILLING REQUIRED TO ABANDON SERVICE AND METER BOX AS PER WATER UTILITY STANDARD SPECIFICATION.
6. REMOVE CORPORATION STOP AND COVER THE HOLE BY A FULL CIRCLE (ONE-SECTION) STAINLESS STEEL REPAIR CLAMP (MUELLER, ROMAC INDUSTRIES INC, FORD METER BOX COMPANY OR APPROVED EQUAL). SEE SECTION 2-08.4. REMOVE A MINIMUM 2-FOOT SECTION OF THE ABANDONED SERVICE LINE FROM THE MAIN AND FROM THE CURB. CRIMP BOTH ENDS OF ABANDONED SERVICE LINE.
7. THE WATER MAINTENANCE DIVISION PERSONNEL SHALL BE CONTACTED AT LEAST 5 WORKING DAYS PRIOR TO START OF JOB IN ORDER TO PREPARE FOR SHUTDOWN. THE CITY CANNOT GUARANTEE A COMPLETE WATER SHUT-DOWN OF EXISTING MAIN. THE CONTRACTOR SHALL BE RESPONSIBLE FOR DEWATERING AND NOTIFY ALL AFFECTED USERS 3 WORKING DAYS PRIOR TO OUTAGES.
8. CONDITIONS OTHER THAN COPPER SHALL BE HANDLED AS FOLLOWS:
 - A. AS SHOWN ABOVE FOR PLASTIC SERVICES.
 - B. SHUTDOWN OF MAIN AND THE REMOVAL OF CORPORATION STOP FOR OTHER TYPE SERVICE MATERIALS OR AS DETERMINED BY INSPECTOR DEPENDING UPON FIELD CONDITIONS.
9. CITY OF WHITTIER STREET EXCAVATION PERMIT IS REQUIRED.

REVISED DATE <u>12/07/17</u> <u>03/19/19</u> <u>06/22/23</u> _____ _____ _____	<h2 style="margin: 0;">CITY OF WHITTIER- WATER DIVISION</h2> <h3 style="margin: 0;">2" AND SMALLER SERVICE LATERAL ABANDONMENT</h3>	DRAWN: HG DESIGN: KAC STD. NO <b style="font-size: 1.2em;">W-645 SHEET <u>1</u> OF <u>1</u>
APPROVED: _____ <div style="display: flex; justify-content: space-between;"> WATER MANAGER _____ DIRECTOR OF PUBLIC WORKS </div>		

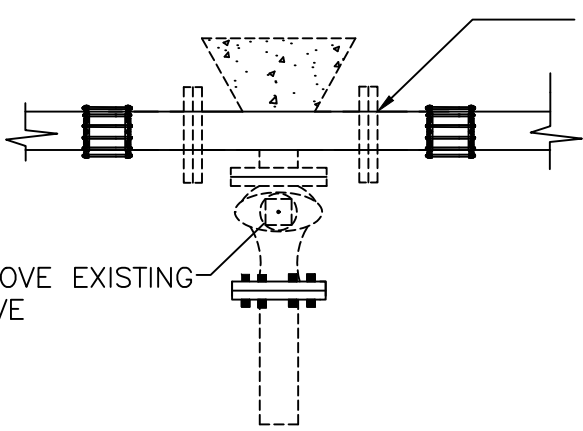

REMOVE EXISTING TEE/CROSS (MINIMUM 24" OR CLOSEST JOINT AND INSTALL NEW SPOOL W/ COUPLINGS PER CITY ENGINEER'S DISCRETION

REMOVE EXISTING VALVE

NOTES:

1. SEE CITY OF WHITTIER WATER STANDARDS SPECIFICATIONS.
2. ALL PIPES AND FITTINGS TO BE ENCASED IN 8 MIL. MIN. POLYETHYLENE WRAP PER SECTION 2-00.
3. WHEN TAPPING VALVE EXISTS AND MAIN LINE CAN BE TAKEN OUT OF SERVICE VALVE SHALL BE REMOVED AND REPLACED WITH A BLIND FLANGE.

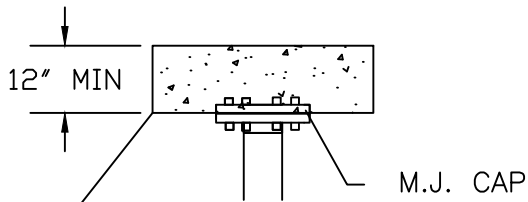

CUT AND REMOVE A SECTION OF EXISTING PIPE REPLACE WITH THRUST BLOCK.

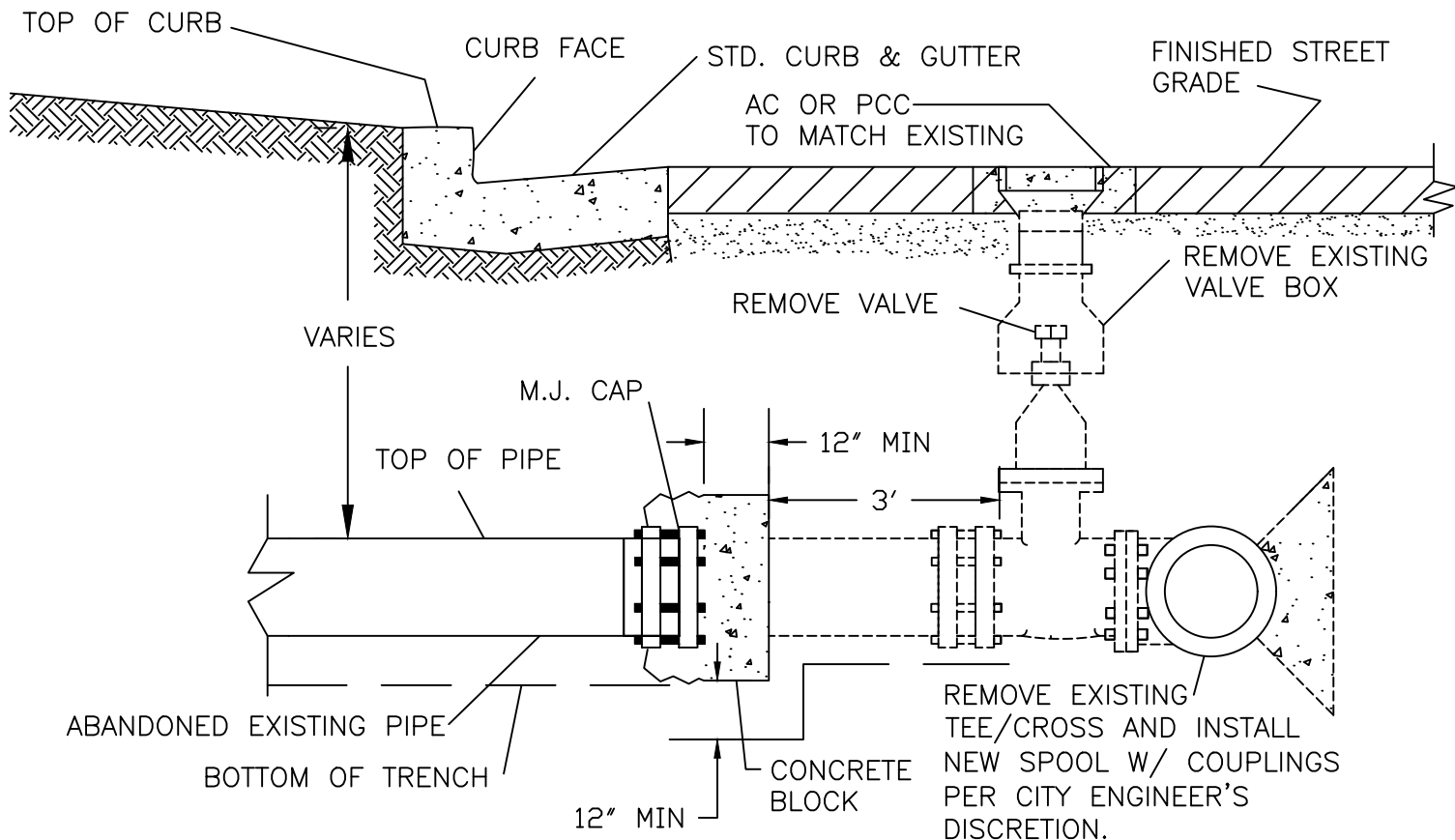

REVISED	
DATE	12/07/17
	03/19/19
	06/22/23

CITY OF WHITTIER- WATER DIVISION

DRAWN: HG
DESIGN: KAC

3" THROUGH 12" PIPELINE ABANDONMENT

STD. NO
W-646

APPROVED: 
WATER MANAGER

DIRECTOR OF PUBLIC WORKS

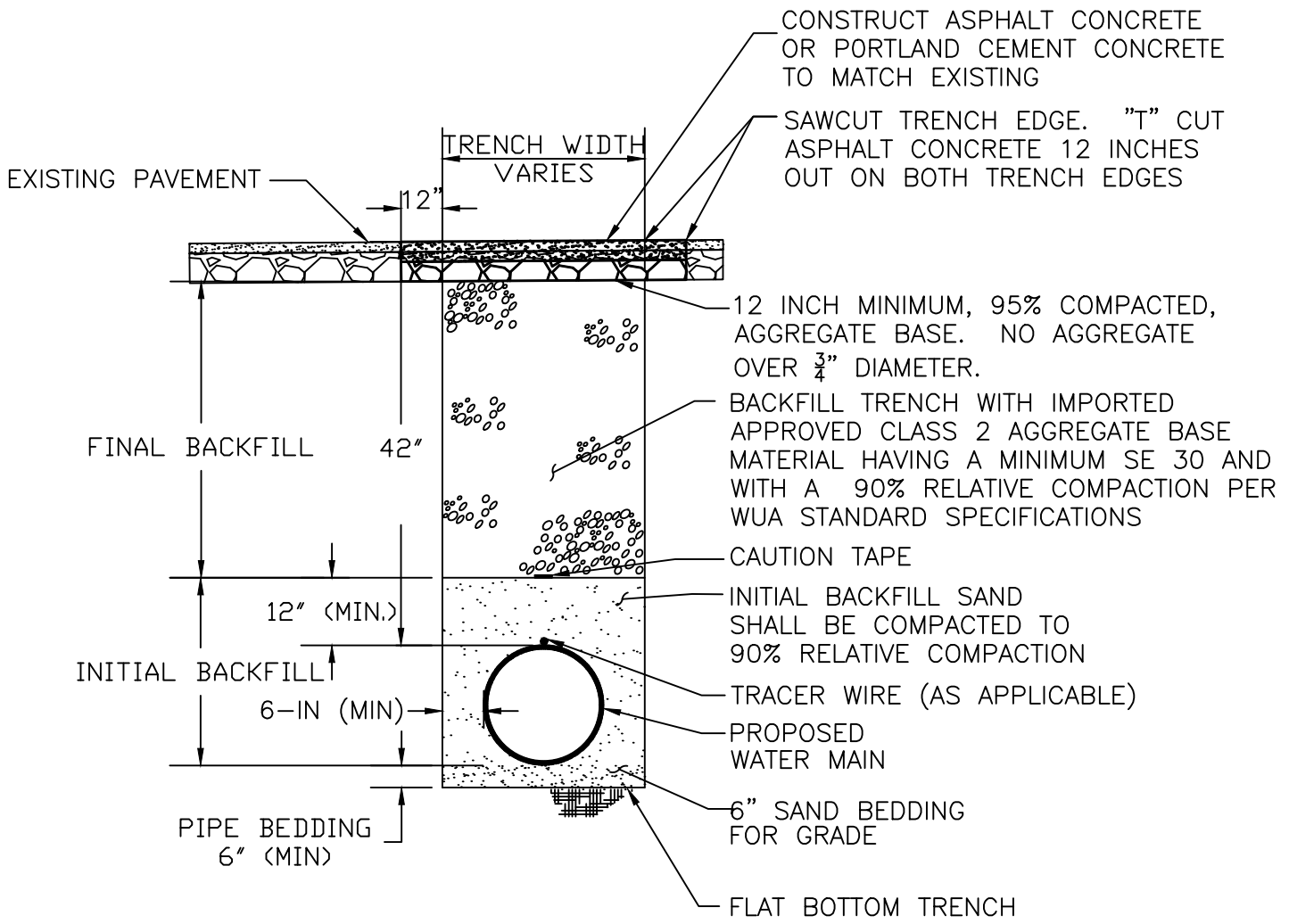

REVISD	
DATE	12/07/17
	03/19/19
	06/22/23

CITY OF WHITTIER- WATER DIVISION

DRAWN: HG
DESIGN: KAC

TYPICAL TRENCH DETAIL

APPROVED: 
WATER MANAGER

DIRECTOR OF PUBLIC WORKS

STD. NO
W-647
SHEET 1 OF 1

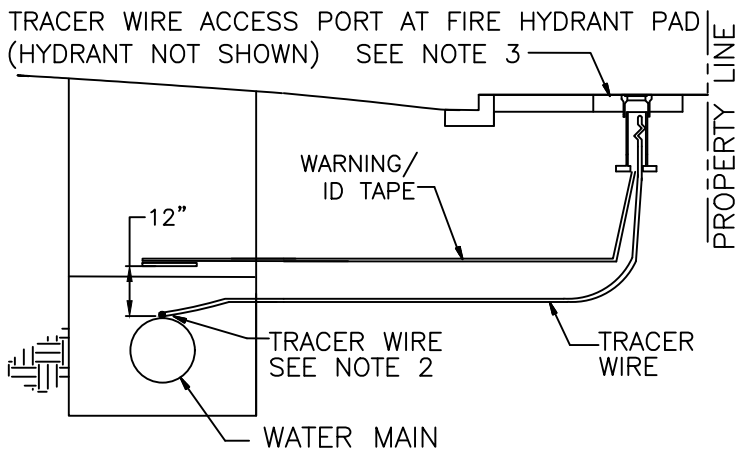

CASE 1

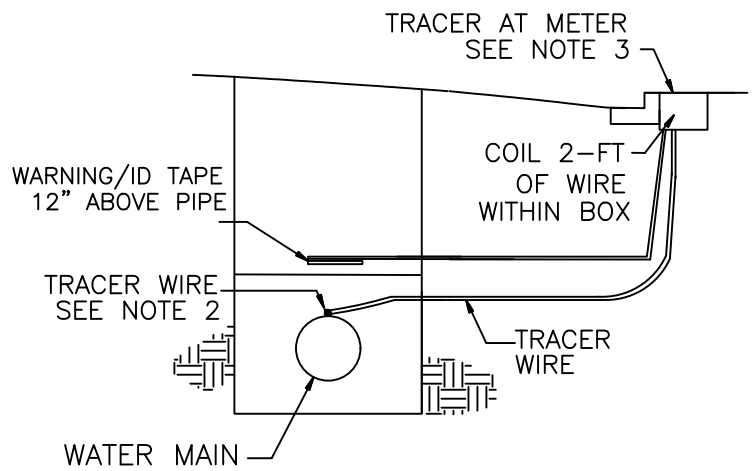

CASE 2

SECTION VIEW

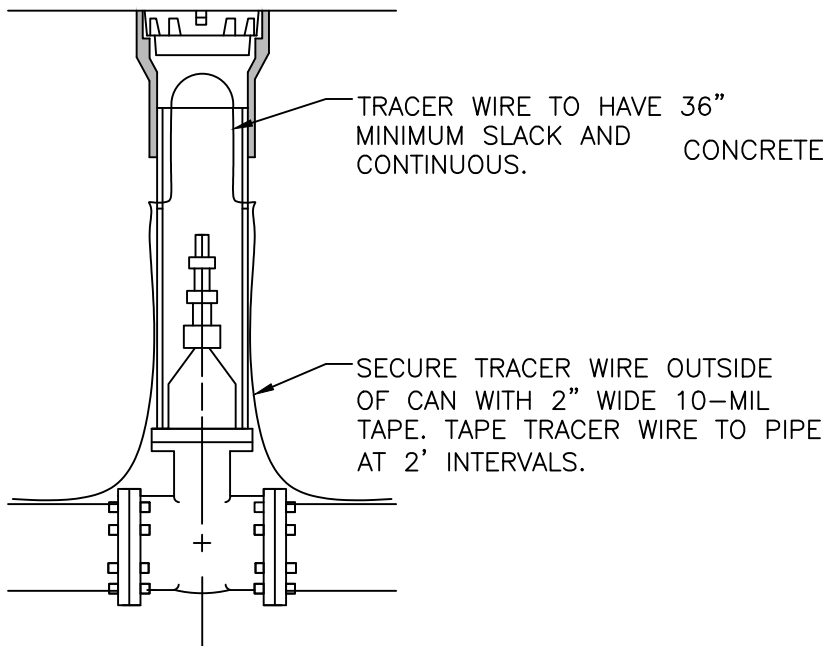

CASE 3

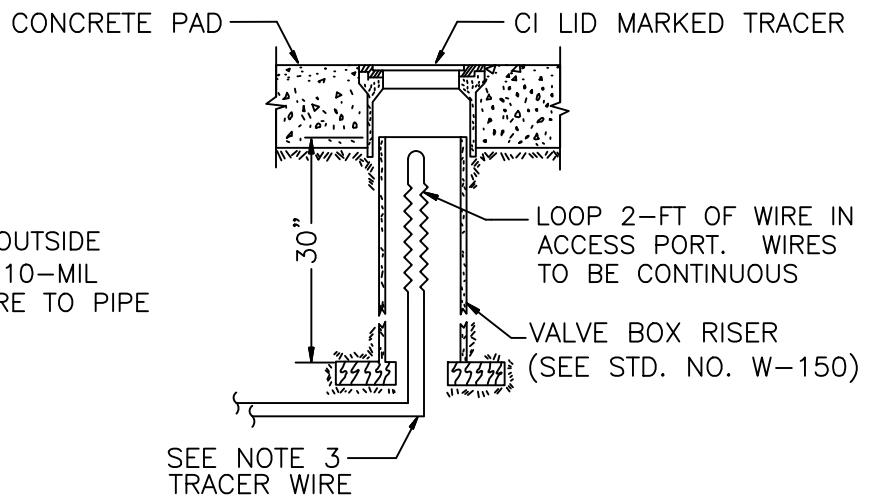

TRACER WIRE ACCESS PORT

NOTES:

1. TRACER WIRE TO BE 10 GAUGE SOLID CCS HIGH STRENGTH
2. TRACER WIRE SHALL BE SECURED TO THE PIPE AT 10-FOOT INTERVALS WITH PLASTIC ADHESIVE TAPE, DUCT TAPE OR PLASTIC TIE STRAPS. THE WIRE SHALL RUN CONTINUOUSLY ALONG THE TOP OF PIPE FOR THE ENTIRE LENGTH OF PIPE AND MAKE CONNECTION WITH ALL SADDLES.
3. TRACER WIRE ACCESS PORT (SHOWN ABOVE) SHALL BE INSTALLED WITHIN THE CONCRETE PAD OF ALL NEW FIRE HYDRANTS INSTALLED AS A PART OF THE WORK. TRACER MAY TERMINATE WITHIN METER BOXES, BLOW OFF BOXES, CP TEST BOXES OR AIR VALVE ENCLOSURES ONLY AS DIRECTED BY THE ENGINEER AT INTERVALS OF NOT MORE THAN 1000- FEET.
4. SUFFICIENT SLACK SHALL BE LEFT IN LEADS NEAR CONNECTIONS TO PIPE TO PREVENT BREAKAGE OF CONNECTION DURING BACKFILLING.
5. WARNING/ IDENTIFICATION TAPE SHALL BE 6-INCH WIDE, BLUE IN COLOR AND MARKED "CAUTION WATER LINE BELOW".
6. A CONTINUITY TEST IS TO BE PERFORMED ON ALL TRACER WIRES.

REVISED	
DATE	12/07/17
	02/15/18
	03/19/19
	06/22/23

CITY OF WHITTIER- WATER DIVISION
WARNING IDENTIFICATION TAPE AND TRACER
WIRE INSTALLATION

APPROVED: 
 WATER MANAGER

 DIRECTOR OF PUBLIC WORKS

DRAWN: HG
 DESIGN: KAC
 STD. NO
W-648
 SHEET 1 OF 1

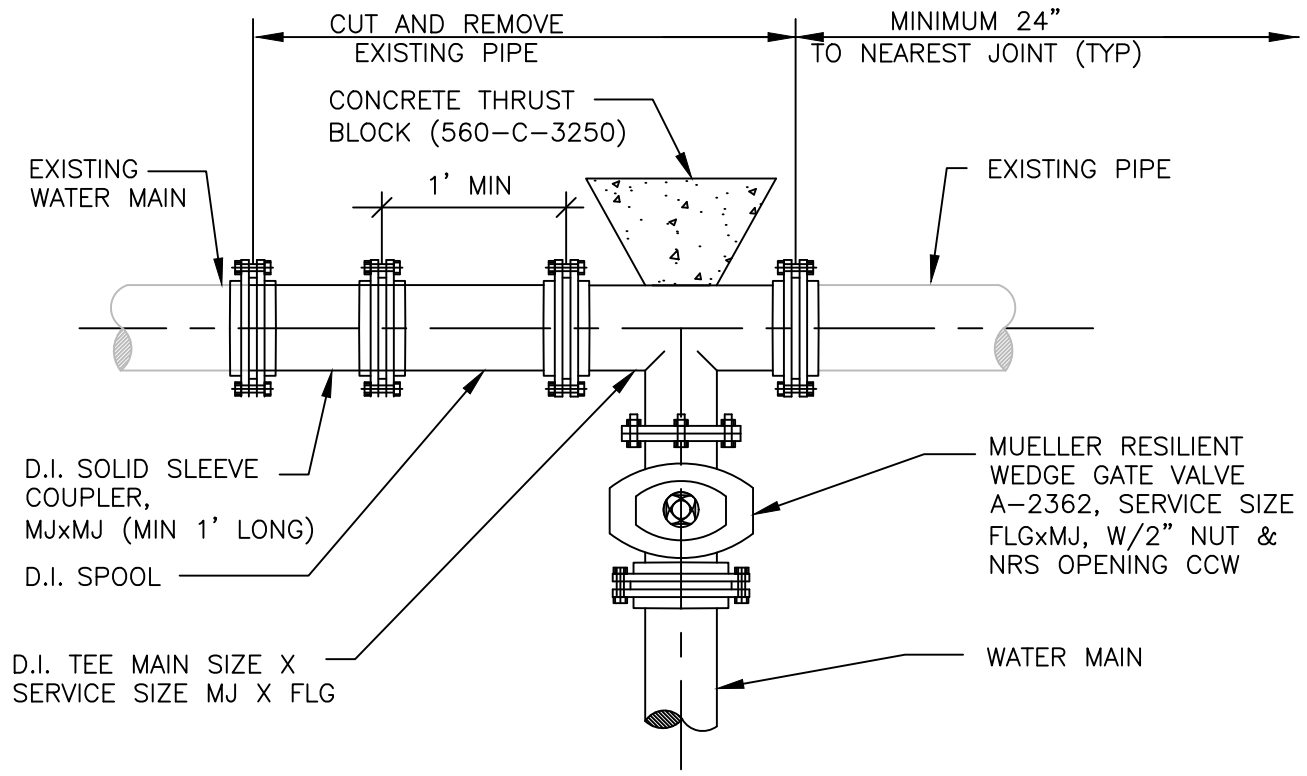

CUT IN METHOD

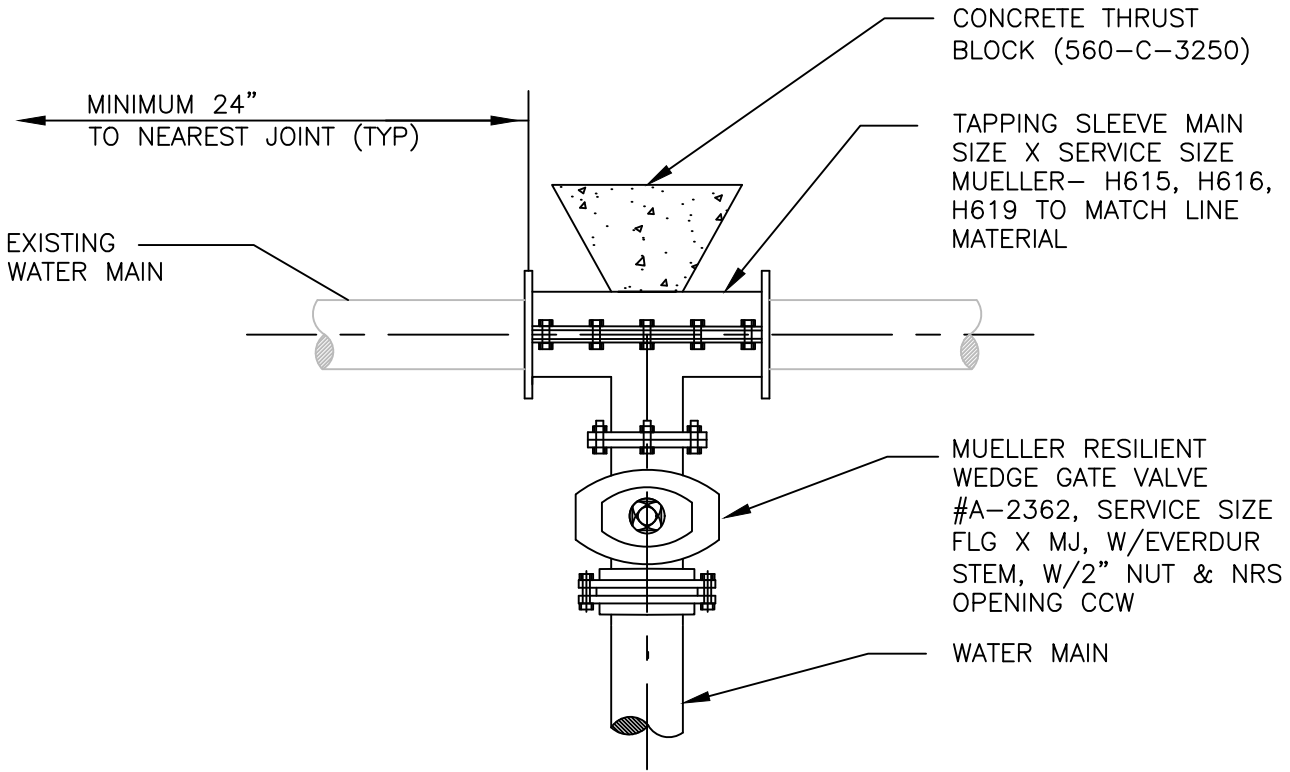

HOT TAP METHOD

REVISED
DATE 06/22/23

CITY OF WHITTIER- WATER DIVISION

CONNECTION TO EXISTING WATER MAIN

APPROVED: _____
WATER MANAGER

DIRECTOR OF PUBLIC WORKS

DRAWN: BG
DESIGN: KAC

STD. NO
W-649

SHEET 1 OF 1

NOTE: THIS STANDARD IS ONLY ALLOWED ON SPECIAL CIRCUMSTANCES & APPROVAL IS REQUIRED BY CITY ENGINEER

EASEMENT TO CITY OF WITHIN LIMITS OF PCC PAD

CITY OF WHITTIER RESPONSIBILITY

PRIVATE SYSTEM MAINTAINED AND TESTED BY PROPERTY OWNER PER CITY OF WHITTIER WATER STANDARDS

(PER BLDG CODE) PRIVATE SYSTEM

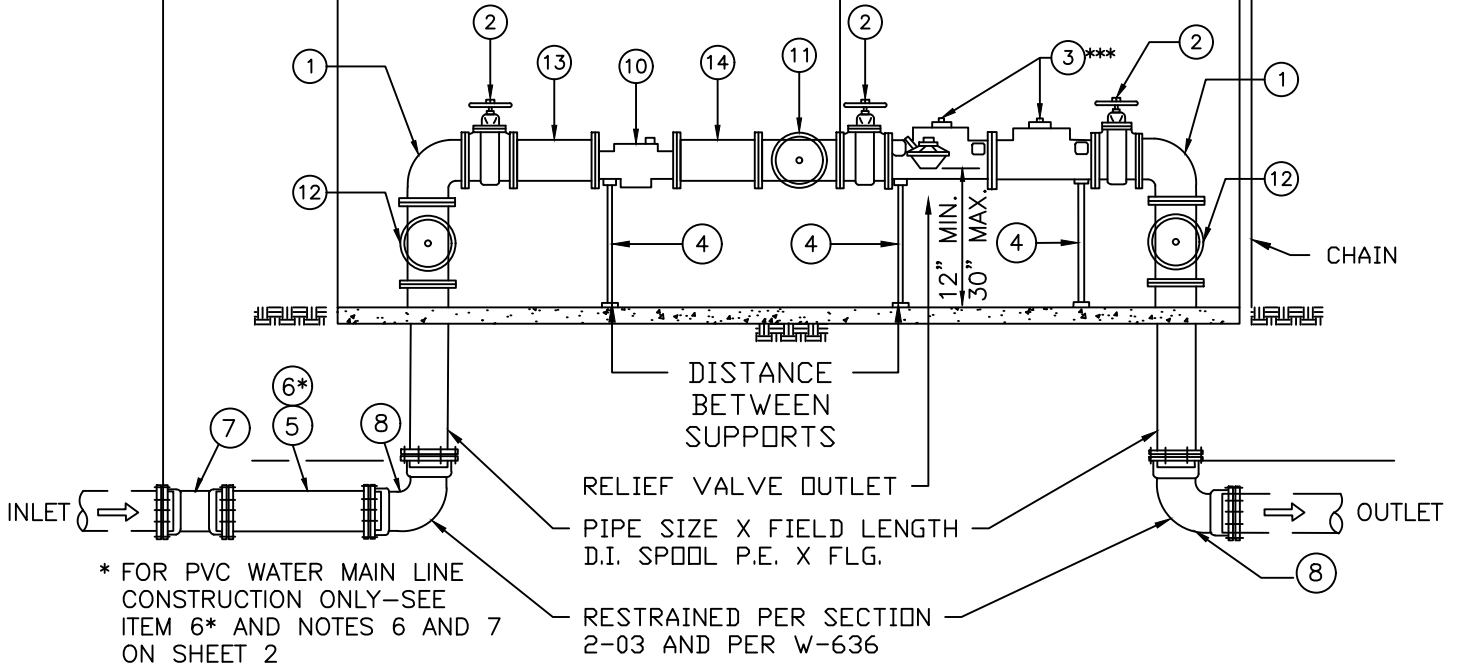

LIST OF MATERIAL

ITEM	DESCRIPTION
1	SR 90° BEND, D.I., FLGxFLG., ADD CHAIN FOR THE WHEELS (BY CUSTOMER)
2	RESILIENT WEDGE VALVE, FLGxFLG, HAND WHEEL (SEE SPECIFICATION SECTION 2-06 FOR REQUIREMENTS).
3	REDUCED PRESSURE PRINCIPLE DETECTOR ASSEMBLY TYPE BACKFLOW PREVENTER (SEE SPECIFICATION SECTION 5-01)
4	SUPPORT, ADJUSTABLE PIPE, FLAT SUPPORT
5	PIPE SIZE X FIELD LENGTH D.I. SPOOL, P.E.xP.E.
6*	IN LIEU OF ITEM 5, PIPE SHALL BE AWWA C900 PVC CLASS 200 (DR 14), P.E.xP.E. (SEE NOTES 6 AND 7)
7	D.I. SOLID SLEEVE M.J.xM.J. (SEE NOTE 5); M.J.'S SHALL BE RESTRAINED PER SECTION 2-12.01.
8	D.I. 90° BEND, M.J.xM.J. (2 TYP.), MJ'S SHALL BE RESTRAINED AS PER SECT, 2-03
9	CONCRETE PAD 4" THICK SIZE AS INDICATED HERIN; CLASS 520-C-2500 CONCRETE
10	WATER METER, OCTAVE
11	D.I. TEE (FLXFLXFL), BLIND FLANGE WITH 2" OUTLET IN CENTER 2" BALL VALVE M.I.P. X F.I.P. WITH LOCK WINGS(FORD B81-777W) AND 2" BRASS PLUG
12	BYPASS (2" SERVICE SADDLE, BALL VALVE W/ LOCK WINGS, BRASS PLUG) OR TEE WITH BLIND FLANGE PER ITEM 11 ABOVE
13	MASTER BRASS SCREEN UNIT; FLOW TESTING ON WHEN IT IS NEEDED
14	PIPE SPOOL 2X PIPE DIAMETER; FOR FLOW

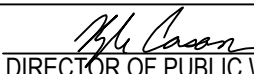
REVISED DATE <u>12/07/17</u> <u>03/19/19</u> <u>06/22/23</u>	CITY OF WHITTIER- WATER DIVISION 3" & ABOVE GROUND METER AND BACKFLOW DETAIL		DRAWN: JG DESIGN: KAC
	APPROVED:  WATER MANAGER	 DIRECTOR OF PUBLIC WORKS	STD. NO W-650 SHEET <u>1</u> OF <u>2</u>



LIST OF MATERIAL

ITEM	DESCRIPTION
1	SR 90° BEND, D.I., FLGxFLG., ADD CHAIN FOR THE WHEELS
2	RESILIENT WEDGE VALVE, FLGxFLG, HAND WHEEL (SEE SPECIFICATION SECTION 2-06 FOR REQUIREMENTS).
3	REDUCED PRESSURE PRINCIPLE DETECTOR ASSEMBLY TYPE BACKFLOW PREVENTER (SEE SPECIFICATION SECTION 5-01)
4	SUPPORT, ADJUSTABLE PIPE, FLAT SUPPORT
5	PIPE SIZE X FIELD LENGTH D.I. SPOOL, P.E.xP.E.
6*	IN LIEU OF ITEM 5, PIPE SHALL BE AWWA C900 PVC CLASS 200 (DR 14), P.E.xP.E. (SEE NOTES 6 AND 7)
7	D.I. SOLID SLEEVE M.J.xM.J. (SEE NOTE 5); M.J.'S SHALL BE RESTRAINED PER SECTION 2-12.01.
8	D.I. 90° BEND, M.J.xM.J. (2 TYP.), MJ'S SHALL BE RESTRAINED AS PER SECT, 2-03
9	CONCRETE PAD 4" THICK SIZE AS INDICATED HERIN; CLASS 520-C-2500 CONCRETE
10	WATER METER, OCTAVE
11	D.I. TEE (FLXFLXFL), BLIND FLANGE WITH 2" OUTLET IN CENTER 2" BALL VALVE M.I.P. X F.I.P. WITH LOCK WINGS(FORD B81-777W) AND 2" BRASS PLUG
12	BYPASS (2" SERVICESADDLE, BALL VALVE W/ LOCK WINGS, BRASS PLUG) OR TEE WITH BLIND FLANGE PER ITEM 11 ABOVE
13	BRASS STRAINER
14	PIPE SPOOL 2X PIPE DIAMTER

LATERAL SIZE	A	B (MAX)	C
4"	7.0'	4'-3"	14"
6"	8.5'	5'-3"	14"
8"	9.5'	6'-4"	13.5"
10"	11.5'	7'-5"	12"

NOTES:

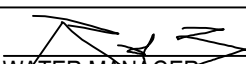
- ALL EXPOSED PIPE AT THE 90° BENDS SHALL BE DUCTILE IRON PER SECTION 2-01.
- ALL PIPE FITTINGS AND APPURTENANCES (GASKETS, NUTS, BOLTS, RESTRAINTS) SHALL COMPLY WITH SECTIONS 2-03 & 2-07.
- SEE STANDARD DRAWING W-604 FOR ABOVE GROUND ASSEMBLY INSTALLATION REQUIREMENTS.
- COMPLETED ASSEMBLY SHALL BE PAINTED PER SECTION 2-14.
- ITEM 7 IS REQUIRED IF BACKFLOW DEVICE ASSEMBLY IS NOT INSTALLED AT THE SAME TIME OF THE LATERAL INSTALLATION.
- PVC WATER MAIN CONSTRUCTION SHALL BE PRE-APPROVED BY THE UTILITY PER SECTION 2-02.
- MECHANICAL JOINT RESTRAINT FOR PIPE SHALL BE RESTRAINED AS PER SECT. 2-03.
- ASSEMBLY SHALL BE APPROVED BY USC FOUNDATION FOR CROSS CONNECTION.
- LOCATION AND INSTALLATION SHALL BE PER PLAN AS SUBMITTED AND APPROVED BY THE UTILITY.
- AFTER INSTALLATION, BACKFLOW SHALL BE TESTED BY AN LA COUNTY CERTIFIED BACKFLOW TESTER. TESTER MUST MAINTAIN AN ACTIVE WHITTIER BUSINESS LICENSE.

REVISED DATE <u>12/07/17</u> <u>03/19/19</u> <u>06/22/23</u>	CITY OF WHITTIER- WATER DIVISION		DRAWN: JG DESIGN: KAC
	3" & ABOVE GROUND METER AND BACKFLOW DETAIL		STD. NO W-650
APPROVED:  WATER MANAGER	 DIRECTOR OF PUBLIC WORKS		SHEET <u>2</u> OF <u>2</u>

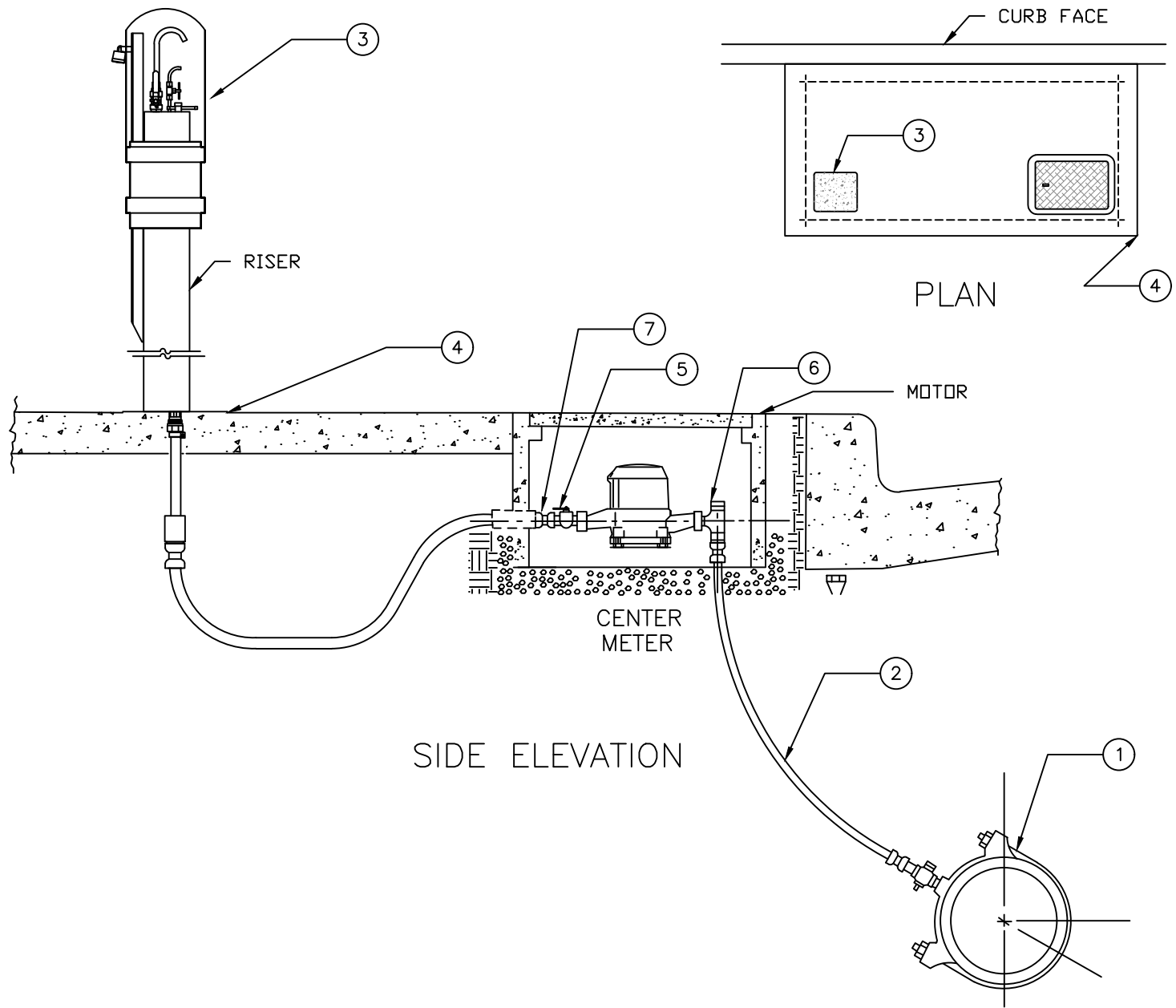

LIST OF MATERIALS

ITEM	DESCRIPTION
1	BRONZE SERVICE CLAMP W/ 1" IRT TAR
2	1" P.E. SERVICE TUBING (CTS PEX MUNIPEX) WITH WIRE PER AV-142
3	MODEL 301D ABOVE GRADE SAMPLING STATION BY WATER PLUS CORPORATION OR APPROVED EQUAL WITH ENCLOSURE
4	2'-6" X 4'-6" X 4" THK. CONCRETE PAD (SIZE MAY VARY)
5	1" BRASS CURB STOP, TEFLON COATED BALL VALVE W/LEVER HANDLE, JONES MOD# J-1905 OR APPROVED EQUAL
6	1" BRASS STREET ELBOW
7	3/4" BRASS MALE IPT X INSTA-TITE C110 CPLG. (3/4" MUELLER H-15426) (TOTAL OF 2)

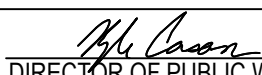
REVISED DATE <u>06/22/23</u> 	CITY OF WHITTIER- WATER DIVISION SAMPLING STATION DETAIL	DRAWN: JG DESIGN: KAC STD. NO W-652 SHEET <u>1</u> OF <u>1</u>
APPROVED:  WATER MANAGER	 DIRECTOR OF PUBLIC WORKS	